Residential Smart Inverter Solutions

ET 15-30kW+Lynx Home F/Lynx Home D

User Manual

Copyright Statement:

Copyright © GoodWe Technologies Co., Ltd. 2024. All rights reserved.

No part of this manual can be reproduced or transmitted to the public platform in any form or by any means without the prior written authorization of GoodWe Technologies Co., Ltd.

Trademarks

GOODWE and other GOODWE trademarks are trademarks of GoodWe Technologies Co., Ltd. All other trademarks or registered trademarks mentioned in this manual are owned by the company.

NOTICE

The information in this user manual is subject to change due to product updates or other reasons. This manual cannot replace the product safety labels unless otherwise specified. All descriptions here are for guidance only.

1 About This Manual

1.1 Overview



The energy storage system consists of inverter, battery system, and smart meter. This manual describes the product information, installation, electrical connection, commissioning, troubleshooting and maintenance of the system. Read through this manual before installing and operating the products. This manual is subject to update without notice. For more product details and latest documents, visit <https://en.goodwe.com/>.

1.2 Applicable Model

The energy storage system consists the following products:

Product type	Product information	Description
Inverter	ET 15-30kW	Rated output power: 15kW - 30kW.
Battery system	Lynx Home F G2	Capacity of single battery system: 12.8kWh - 28.8kWh. Max capacity of parallel connected battery systems: 230.4kWh.
	Lynx Home F, Lynx Home F Plus+	Capacity of single battery system: 6.6kWh - 16.38kWh. Max capacity of parallel connected battery systems: 131.04kWh.
	Lynx Home D	Capacity of single battery system: 5kWh. Max capacity of parallel connected battery systems: 40kWh.
Smart meter	GM3000	Monitors and detects running data in the system, such as voltage, current, etc..
	GM330	
Smart dongle	WiFi/LAN Kit-20	Uploads the system running information to the monitoring platform through WiFi or LAN.
	Wi-Fi Kit	Uploads the system running information to the monitoring platform through WiFi.
	Ezlink3000	Connects to the master inverter when multi inverters are parallel connected. Uploads the system running information to the monitoring platform through WiFi or LAN.

1.3 Symbol Definition

 DANGER
Indicates a high-level hazard that, if not avoided, will result in death or serious injury.
 WARNING
Indicates a medium-level hazard that, if not avoided, could result in death or serious injury.
 CAUTION
Indicates a low-level hazard that, if not avoided, could result in minor or moderate injury.
NOTICE
Highlight and supplement the texts. Or some skills and methods to solve product-related problems to save time.

2 Safety Precautions

Please strictly follow these safety instructions in the user manual during the operation.

WARNING

The products are designed and tested strictly to comply with related safety rules. Read and follow all the safety instructions and cautions before any operations. Improper operation might cause personal injury or property damage as the products are electrical equipment.

2.1 General Safety

NOTICE

- The information in this user manual is subject to change due to product updates or other reasons. This manual cannot replace the product safety labels unless otherwise specified. All descriptions here are for guidance only.
- Before installations, read through the user manual to learn about the product and the precautions.
- All operations should be performed by trained and knowledgeable technicians who are familiar with local standards and safety regulations.
- Use insulating tools and wear personal protective equipment (PPE) when operating the equipment to ensure personal safety. Wear anti-static gloves, cloths, and wrist strips when touching electronic devices to protect the equipment from damage.
- Unauthorized dismantling or modification may damage the equipment, the damage is not covered under the warranty.
- Strictly follow the installation, operation, and configuration instructions in this manual. The manufacturer shall not be liable for equipment damage or personal injury if you do not follow the instructions. For more warranty details, please visit <https://en.goodwe.com/warranty>

2.2 Personnel Requirements

NOTICE

- Personnel who install or maintain the equipment must be strictly trained, learn about safety precautions and correct operations.
- Only qualified professionals or trained personnel are allowed to install, operate, maintain, and replace the equipment or parts.

2.3 System Safety

DANGER

- Disconnect the upstream and downstream switches to power off the equipment before any electrical connections. Do not work with power on. Otherwise, an electric shock may occur.
- Install a breaker at the voltage input side of the equipment to prevent personal injury or equipment damage caused by energized electrical work.
- All operations such as transportation, storage, installation, use and maintenance shall comply with applicable laws, regulations, standards and specifications.
- Perform electrical connections in compliance with local laws, regulations, standards and specifications. Including operations, cables, and component specifications.
- Connect cables using the connectors included in the package. The manufacturer shall not be liable for equipment damage if other connectors are used.
- Ensure all cables are connected tightly, securely, and correctly. Inappropriate wiring may cause poor contacts and damage the equipment.
- The PE cables must be connected and secured properly.
- To protect the equipment and components from damage during transportation, ensure that the transportation personnel are professionally trained. All operations during the transportation have to be recorded. The equipment shall be kept in balance, thus avoiding falling down.
- The equipment is heavy. Please equip the corresponding personnel according to its weight, so that the equipment does not exceed the weight range of the human body can carry, and cause personnel injury.
- Keep the equipment stable to avoid dumping, which can result in equipment damage and personal injuries.
- Do not wear any metal thing when moving, installing, or commissioning the equipment. Otherwise, it will cause electrical shock or damages to the equipment.
- Do not put any metal parts on the equipment, otherwise it will cause electrical shock.

WARNING

- Do not apply mechanical load to the terminals, otherwise the terminals can be damaged.
- If the cable bears too much tension, the connection may be poor. Reserve a certain length of the cable before connecting it to corresponding ports.
- Tie the cables of the same type together, and place cables of different types at least 30mm apart. Do not place the cables entangled or crossed.
- Place the cables at least 30mm away from the heating components or heat sources, otherwise the insulation layer of the cables may be aging or broken due to high temperature.

2.3.1 PV String Safety

 **WARNING**

- Ensure the component frames and the bracket system are securely grounded.
- Ensure the DC cables are connected tightly, securely and correctly. Inappropriate wiring may cause poor contacts or high impedance, and damage the inverter.
- Measure the DC cable using the multimeter to avoid reverse polarity connection. Also, the voltage should be under the max DC input voltage. The manufacturer shall not be liable for the damage caused by reverse connection and extremely high voltage.
- The PV strings cannot be grounded. Ensure the minimum insulation resistance of PV string to the ground meets the minimum insulation resistance requirements before connecting the PV string to the inverter ($R = \text{maximum input voltage (V)} / 30\text{mA}$).
- Do not connect one PV string to more than one inverter at the same time. Otherwise, it may cause damage to the inverter.
- The PV modules used with the inverter must have an IEC61730 class A rating.
- The inverter output power may decrease if the PV string inputs high voltage or current.

2.3.2 Inverter Safety

 **WARNING**

- The voltage and frequency at the connecting point should meet the on-grid requirements.
- Additional protective devices like circuit breakers or fuses are recommended on the AC side. Specification of the protective device should be at least 1.25 times the maximum AC output current.
- The arc fault alarms will be cleared automatically if the alarms are triggered less than 5 times in 24 hours. The inverter will shutdown for protection after the 5th electric arc fault. The inverter can operate normally after the fault is solved.
- BACK-UP is not recommended if the PV system is not configured with batteries. Otherwise, there may be a risk of system power outage.
- The inverter output power may decrease when the grid voltage and frequency changes.

2.3. 3 Battery Safety

DANGER

- The battery system exists high voltage during the equipment running. Keep Power Off before any operations to avoid danger. Strictly follow all safety precautions outlined in this manual and safety labels on the equipment during the operation.
- Do not disassemble, modify, or replace any part of the battery or the power control unit without official authorization from the manufacturer. Otherwise, it will cause electrical shock or damages to the equipment, which shall not be borne by the manufacturer.
- Do not hit, pull, drag, squeeze or step on the equipment or put the battery into fire. Otherwise, the battery may explode.
- Do not place the battery in a high temperature environment. Make sure that there is no direct sunlight and no heat source near the battery. When the ambient temperature exceeds 60°C, it will cause a fire.
- Do not use the battery or the power control unit if it is defective, broken, or damaged. Damaged battery may leak electrolyte.
- Do not move the battery system while it is working.
- Contact after-sales service if the battery shall be replaced or added.
- A short circuit in the battery may cause personal injury. The instantaneous high current caused by a short circuit can release a large amount of energy and may cause a fire.

WARNING

- If the battery discharged completely, please charge it in strict accordance with the corresponding model's user manual.
- Factors such as: temperature, humidity, weather conditions, etc. may limit the battery's current and affect its load.
- Contact after-sale service immediately if the battery is not able to be started. Otherwise, the battery might be damaged permanently.

Emergency Measures

● Battery Electrolyte Leakage

If the battery module leaks electrolyte, avoid contact with the leaking liquid or gas. The electrolyte is corrosive. It will cause skin irritation or chemical burn to the operator. Anyone contact the leaked substance accidentally has to do as following:

- **Breath in the leaked substance:** Evacuate from the polluted area, and seek immediate medical assistance.
 - **Eye contact:** Rinse your eyes for at least 15 minutes with clean water and seek immediate medical assistance.
 - **Skin contact:** Thoroughly wash the touch area with soap and clean water, and seek immediate medical assistance.
 - **Ingestion:** Induce vomiting, and seek immediate medical assistance.
- **Fire**
- The battery may explode when the ambient temperature exceeds 150°C. Poisonous and hazardous gas may be released if the battery is on fire.

- In the event of a fire, please make sure that the carbon dioxide extinguisher or Novec1230 or FM-200 is nearby.
- The fire cannot be put out by ABC dry powder extinguisher. Firefighters are required to wear full protective clothing and self-contained breathing apparatus.

2.3. 4 Smart Meter Safety







WARNING













If the voltage of the power grid fluctuates, resulting in the voltage to exceed 265V, in this case, long-term overvoltage operation may cause damage to the meter. It is recommended to add a fuse with a rated current of 0.5A on the voltage input side of the meter to protect it.



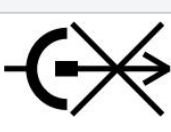

2.4 Safety Symbols And Certification Marks

DANGER

- All labels and warning marks should be visible after the installation. Do not cover, scrawl, or damage any label on the equipment.
- The following descriptions are for reference only.

No.	Symbol	Descriptions
1		Potential risks exist. Wear proper personnel protective equipment before any operations.
2		HIGH VOLTAGE HAZARD Disconnect all incoming power and turn off the product before working on it.
3		High-temperature hazard. Do not touch the product under operation to avoid being burnt.
4		Operate the equipment properly to avoid explosion.
5		Batteries contain flammable materials, beware of fire.
6		The equipment contains corrosive electrolytes. In case of a leak in the equipment, avoid contact the leaked liquid or gas.

7		Delayed discharge. Wait 5 minutes after power off until the components are completely discharged.
8		Install the equipment away from fire sources.
9		Keep the equipment away from children.
10		Operate the equipment properly to avoid explosion.
11		Batteries contain flammable materials, beware of fire.
12		Do not lift the equipment after wiring or when the equipment is working.
13		Do not pour with water.
14		Read through the user manual before any operations.
15		Wear personal protective equipment during installation, operation and maintaining.
16		Do not dispose of the product as household waste. Discard the product in compliance with local laws and regulations, or send it back to the manufacturer.
17		Do not disconnect or plug and unplug the DC connectors during the operation of the equipment.
18		Grounding point.

19		Recycle regeneration mark.
20		CE mark
21		TUV mark
22		RCM mark

2.5 EU Declaration of Conformity

2.5.1 Equipment With Wireless Communication Modules

GoodWe Technologies Co., Ltd. hereby declares that the equipment with wireless communication modules sold in the European market meets the requirements of the following directives:

- Radio Equipment Directive 2014/53/EU (RED)
- Restrictions of Hazardous Substances Directive 2011/65/EU and (EU) 2015/863 (RoHS)
- Waste Electrical and Electronic Equipment 2012/19/EU
- Registration, Evaluation, Authorization and Restriction of Chemicals (EC) No 1907/2006 (REACH)

2.5.2 Equipment Without Wireless Communication Modules (Except Battery)

GoodWe Technologies Co., Ltd. hereby declares that the equipment without wireless communication modules sold in the European market meets the requirements of the following directives:

- Electromagnetic compatibility Directive 2014/30/EU (EMC)
- Electrical Apparatus Low Voltage Directive 2014/35/EU (LVD)
- Restrictions of Hazardous Substances Directive 2011/65/EU and (EU) 2015/863 (RoHS)
- Waste Electrical and Electronic Equipment 2012/19/EU
- Registration, Evaluation, Authorization and Restriction of Chemicals (EC) No 1907/2006 (REACH)

2.5.3 Battery

GoodWe Technologies Co., Ltd. hereby declares that batteries sold in the European market meets the requirements of the following directives:

- Electromagnetic compatibility Directive 2014/30/EU (EMC)
- Electrical Apparatus Low Voltage Directive 2014/35/EU (LVD)
- Battery Directive 2006/66/EC and Amending Directive 2013/56/EU

-
- Waste Electrical and Electronic Equipment 2012/19/EU
 - Registration, Evaluation, Authorization and Restriction of Chemicals (EC) No 1907/2006 (REACH)
- You can download the EU Declaration of Conformity on the official website: <https://en.goodwe.com>.

3 System Introduction

3.1 System Overview

The residential smart inverter solution consists of inverter, battery system, smart meter, smart dongle, etc.. In the PV system, solar energy can be convert to electric energy for household needs. The IoT devices in the system controls the electrical equipment by recognizing the overall power consumption situation. So that the power will be managed in a smart way, deciding whether the power is to be used by the loads, stored in batteries, or exported to the grid, etc.

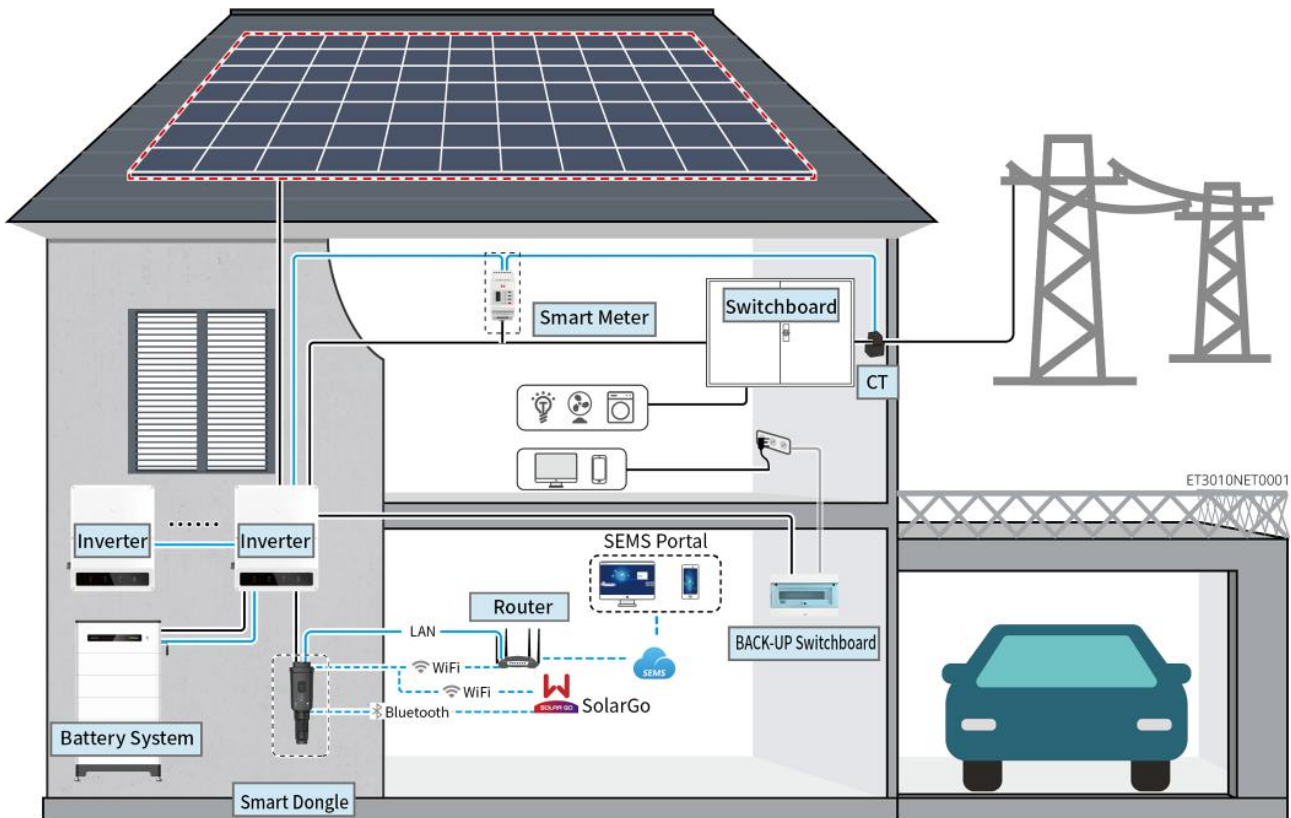

Product Type	Model			Description
Inverter	GW15K-ET GW20K-ET GW25K-ET GW29.9K-ET GW30K-ET			<p>A maximum of 4 inverters can be connected in a parallel system.</p> <p>Inverter firmware requirements for parallel connections:</p> <ul style="list-style-type: none"> ● Consistent firmware version ● ARM version: 08.401 or above ● DSP version: 07.7068 or above
Battery system	Lynx Home F G2 LX F12.8-H-20 LX F16.0-H-20 LX F19.2-H-20	Lynx Home F, Lynx Home Plus+ LX F6.6-H	Lynx Home D LX D5.0-10	<ul style="list-style-type: none"> ● The Lynx Home F series battery system cannot be parallel clustered. ● A maximum of 8 battery systems can be clustered in a

	LX F22.4-H-20 LX F25.6-H-20 LX F28.8-H-20	LX F9.8-H LX F13.1-H LX F16.4-H		system. <ul style="list-style-type: none"> Do not mix connect battery systems of different versions.
Smart meter	GM3000 GM330			<ul style="list-style-type: none"> GM3000: GM3000 and the CT, which cannot be replaced, are included in the inverter package. CT ratio: 120A/40mA. GM330: order the CT for GM330 from GoodWe or other suppliers. CT ratio: nA/5A. <ul style="list-style-type: none"> nA: CT primary input current, n ranges from 200 to 5000. 5A: CT Secondary input current.
Smart dongle	WiFi/LAN Kit-20 Wi-Fi Kit Ezlink3000			<ul style="list-style-type: none"> In single scenarios, WiFi/LAN Kit-20, Wi-Fi kit can be used. Use WiFi/LAN Kit-20 or Wi-Fi kit for a single inverter. Upgrade the firmware of the inverter before replacing the Wi-Fi kit with a WiFi/LAN Kit-20 dongle. In parallel scenarios, the EzLink 3000 must be connected to the master inverter. Do not connect any communication module to the slave inverters. The firmware version of EzLink3000 should be 04 or above.

3.2 Product Overview

3.2.1 Inverter

Inverters control and optimize the power in PV systems through an integrated energy management system. The power generated in the PV system can be used, stored in the battery, output to the utility grid, etc.

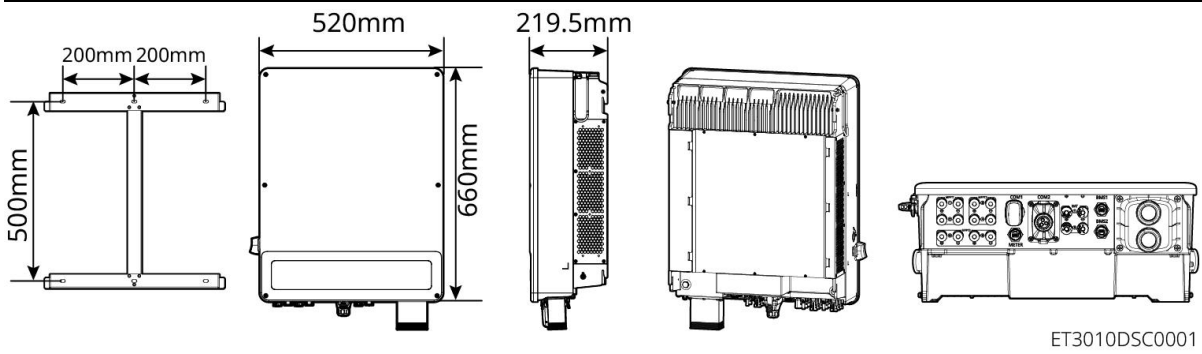

No.	Model	Nominal output power	Nominal output voltage	Number of battery ports
1	GW15K-ET	15kW	380/400V, 3L/N/PE	1
2	GW20K-ET	20kW		1
3	GW25K-ET	25kW		2
4	GW29.9K-ET	29.9kW		2
5	GW30K-ET	30kW		2

3.2.2 Battery System

The Lynx Home F battery system consists of a power control unit and battery modules. The Lynx Home D battery system consists of integrated BMS and battery modules.

The battery system can store and release electricity according to the requirements of the PV energy storage system, and the input and output ports of the energy storage system are all high-voltage direct current.

Lynx Home F, Lynx Home F Plus+

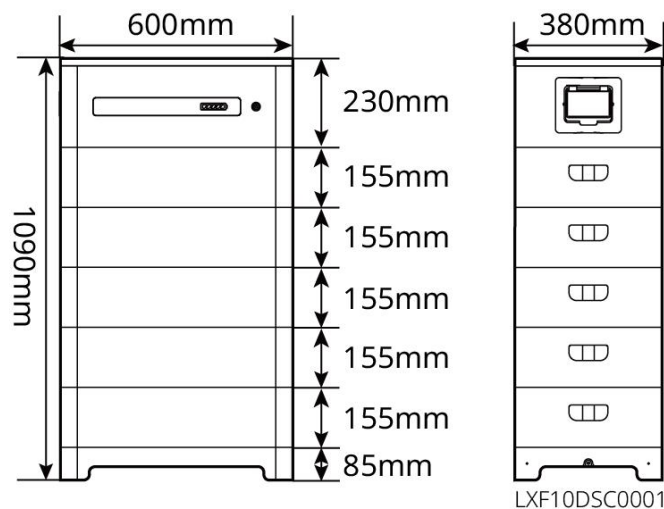

No.	Model	Number of modules	Usable energy (kWh)
1	LX F6.6-H	2	6.55kWh

2	LX F9.8-H	3	9.83kWh
3	LX F13.1-H	4	13.1kWh
4	LX F16.4-H	5	16.38kWh

Lynx Home F G2

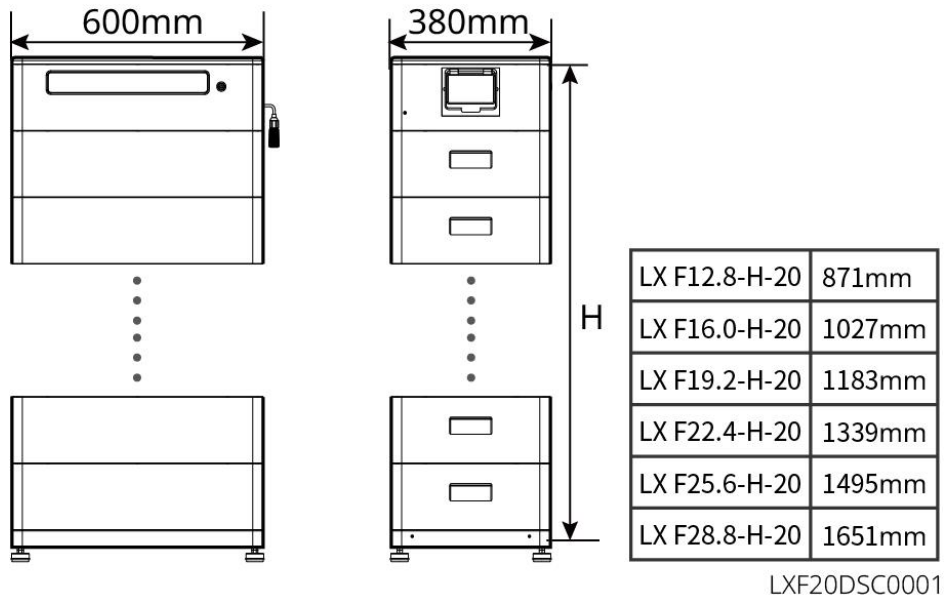

No.	Model	Number of modules	Usable energy (kWh)
1	LX F12.8-H-20	4	12.8kWh
2	LX F16.0-H-20	5	16.0kWh
3	LX F19.2-H-20	6	19.2kWh
4	LX F22.4-H-20	7	22.4kWh
5	LX F25.6-H-20	8	25.6kWh
6	LX F28.8-H-20	9	28.8kWh

Lynx Home D

NOTICE

Mounting base or wall mounting rack optional.

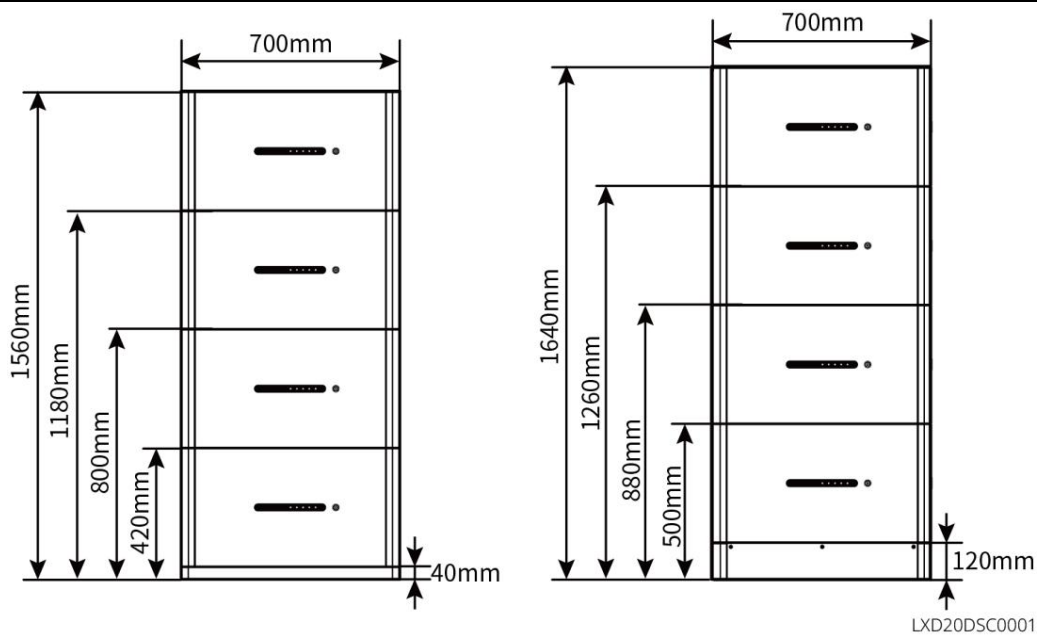

3.2.3 Smart Meter

The smart meter can measure the grid voltage, current, power, frequency, electric energy and other parameters, and transfer the data to the inverter to control the input and output power of the energy storage system.

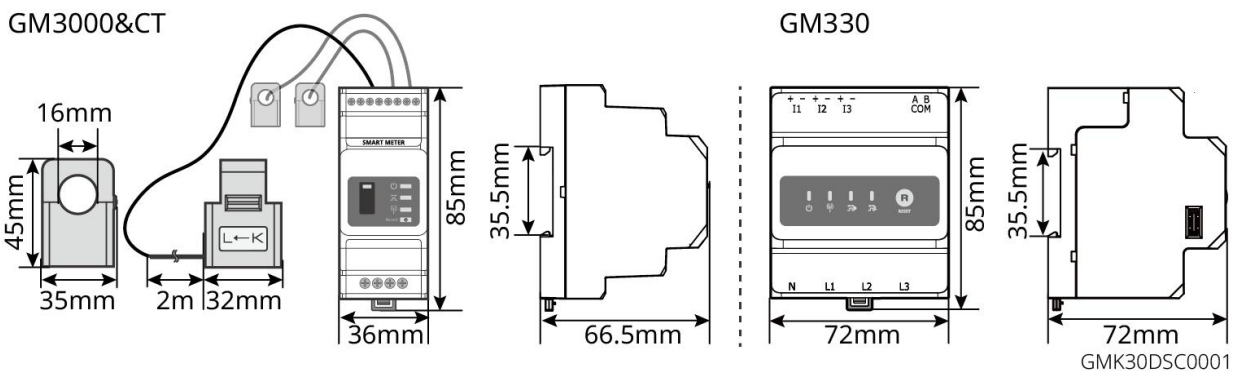

No.	Model	Applicable scenarios
1	GM3000	GM3000 and the CT, which cannot be replaced, are included in the inverter package. CT ratio: 120A/40mA.
2	GM330	Order the CT for GM330 from GoodWe or other suppliers. CT ratio: nA/5A. <ul style="list-style-type: none"> ● nA: CT primary input current, n ranges from 200 to 5000. ● 5A: CT Secondary input current.

3.2.4 Smart Dongle

The smart dongle can transmit various power generation data to SEMS Portal, the remote monitoring platform, in real time. And connect to the SolarGo app to complete local equipment commissioning.

WiFi/LAN Kit-20

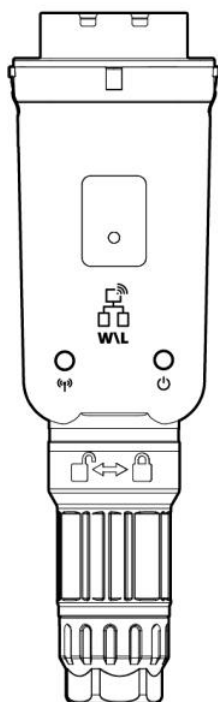

Wi-Fi Kit

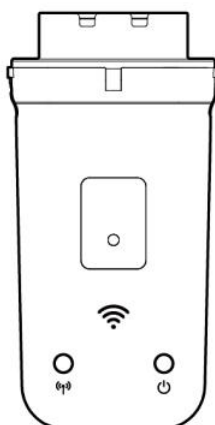

Ezlink3000

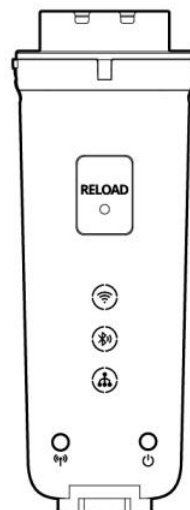

WLA20DSC0001

No.	Model	Signal	Applicable scenarios
1	Wi-Fi Kit	WiFi	Single inverter
2	WiFi/LAN Kit-20	WiFi, LAN, bluetooth	
3	Ezlink3000	WiFi, LAN, bluetooth	Master inverter of the parallel connected inverters

3.3 Supported Grid Types

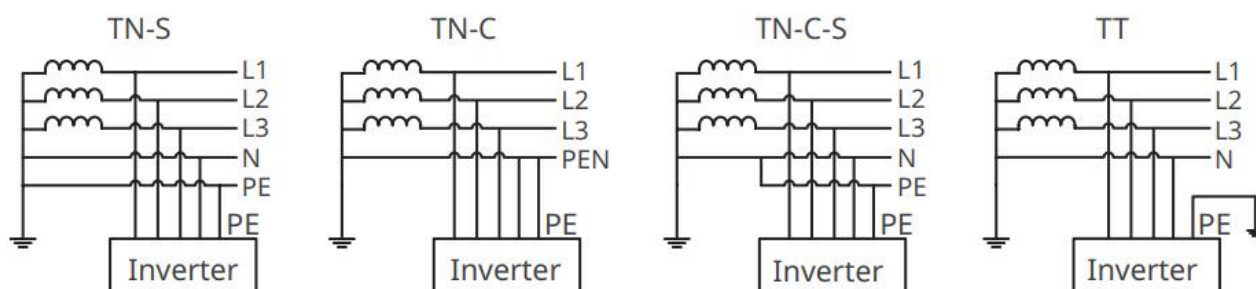

3.4 System Working Mode

Self-use Mode

- Self-use mode is the basic working mode of the system.
- When the power generated in the PV system is sufficient, it will supply the loads in priority. The excess power will charge the batteries first, then the remaining power will be sold to the utility grid.

When the power generated in the PV system is insufficient, the battery will supply the loads in priority. If the battery power is insufficient, the load will be powered by the utility grid.

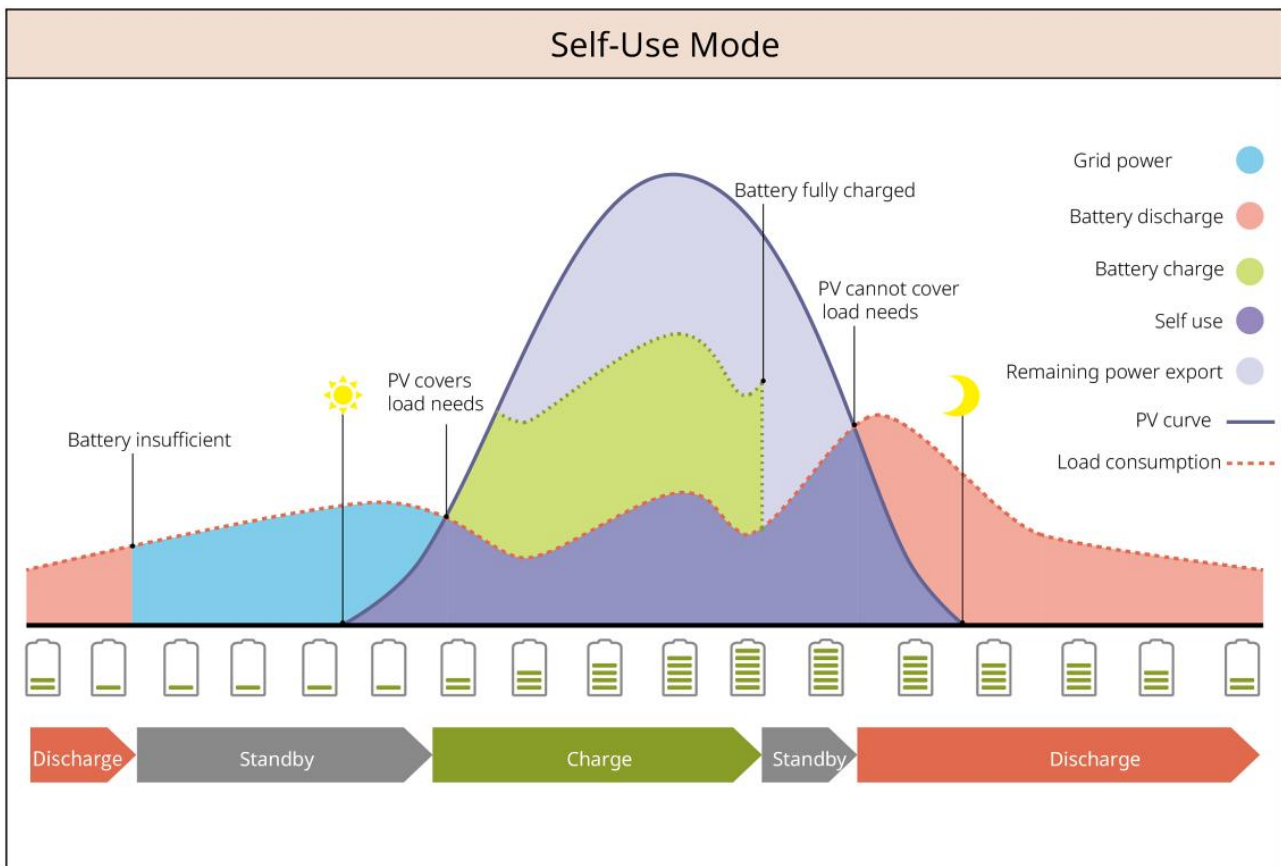

Back-up Mode

- The back-up mode is mainly applied to the scenario where the grid is unstable.
- When the grid is disconnected, the inverter turns to off-grid mode and the battery will supply power to the BACK-UP loads; when the grid is restored, the inverter switches to grid-tied mode.
- The battery will be charged to preset SOC protection value by utility grid or PV when the system is running on-grid. So that the battery SOC is sufficient to maintain normal working when the system is off-grid. The purchase of electricity from the power grid to charge the battery must comply with local laws and regulations.

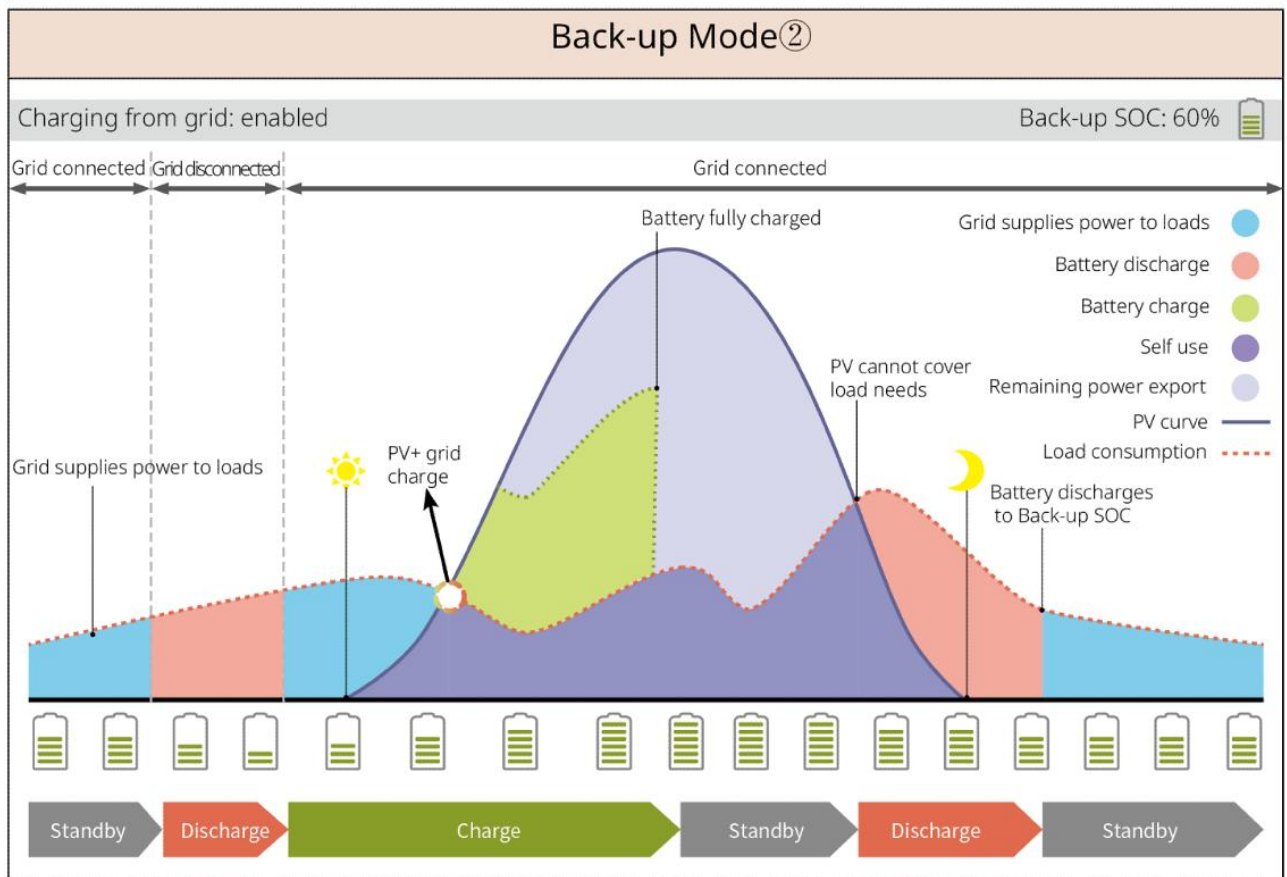
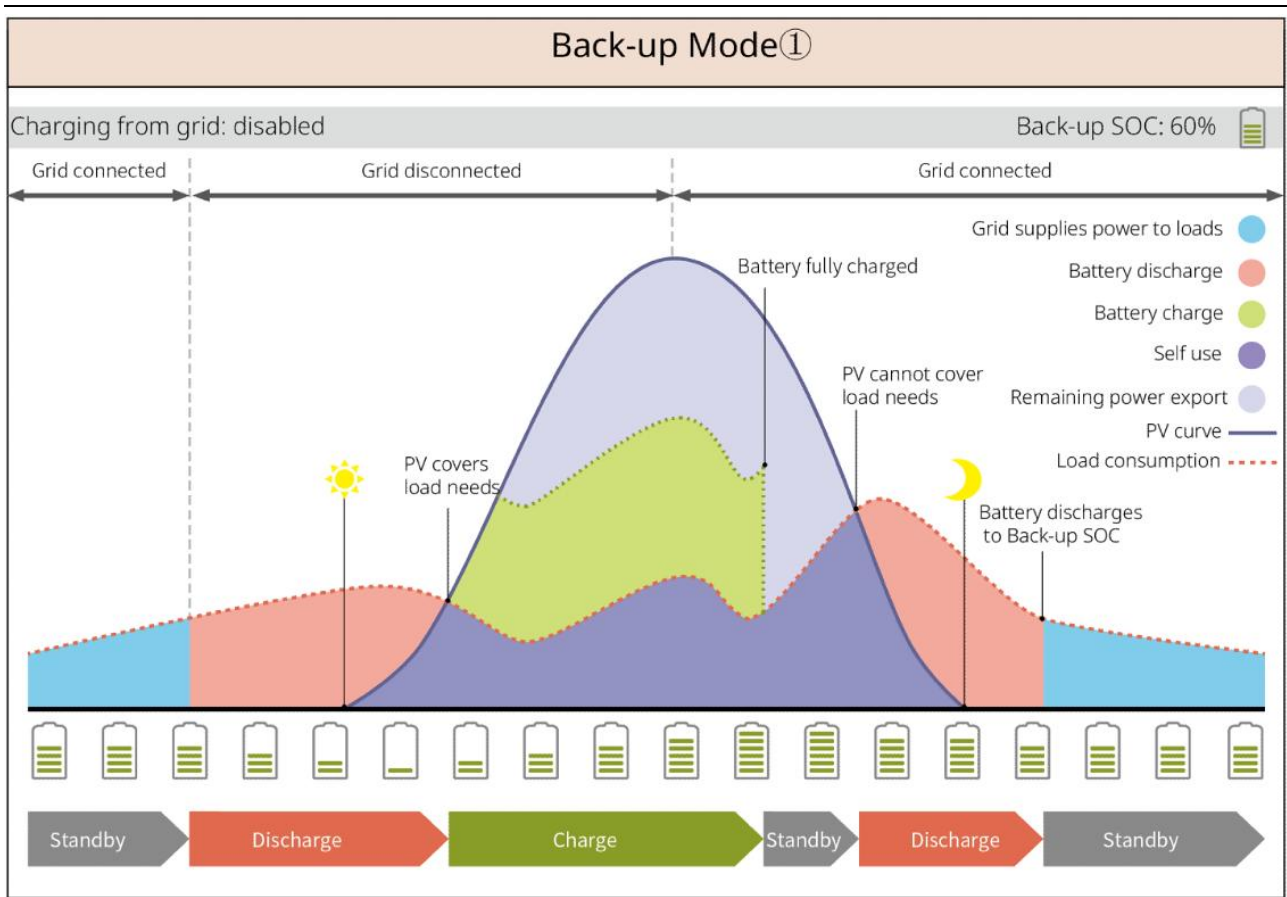

Economic Mode

It is recommended to use economic mode in scenarios when the peak-valley electricity price varies a lot. Select economic mode only when it meets the local laws and regulations.

For example, set the battery to charge mode during Valley period to charge battery with grid power. And set the battery to discharge mode during Peak period to power the load with the battery.

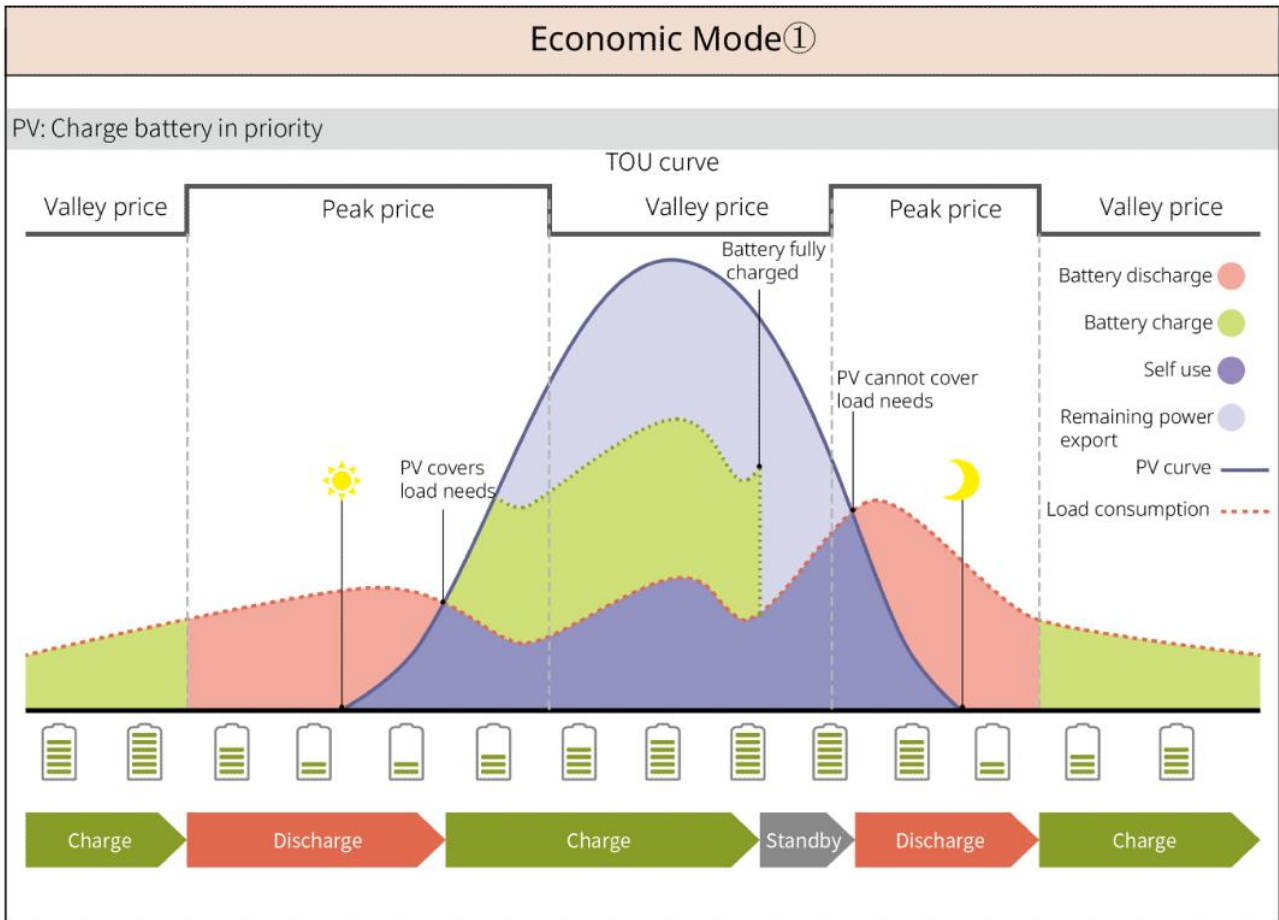

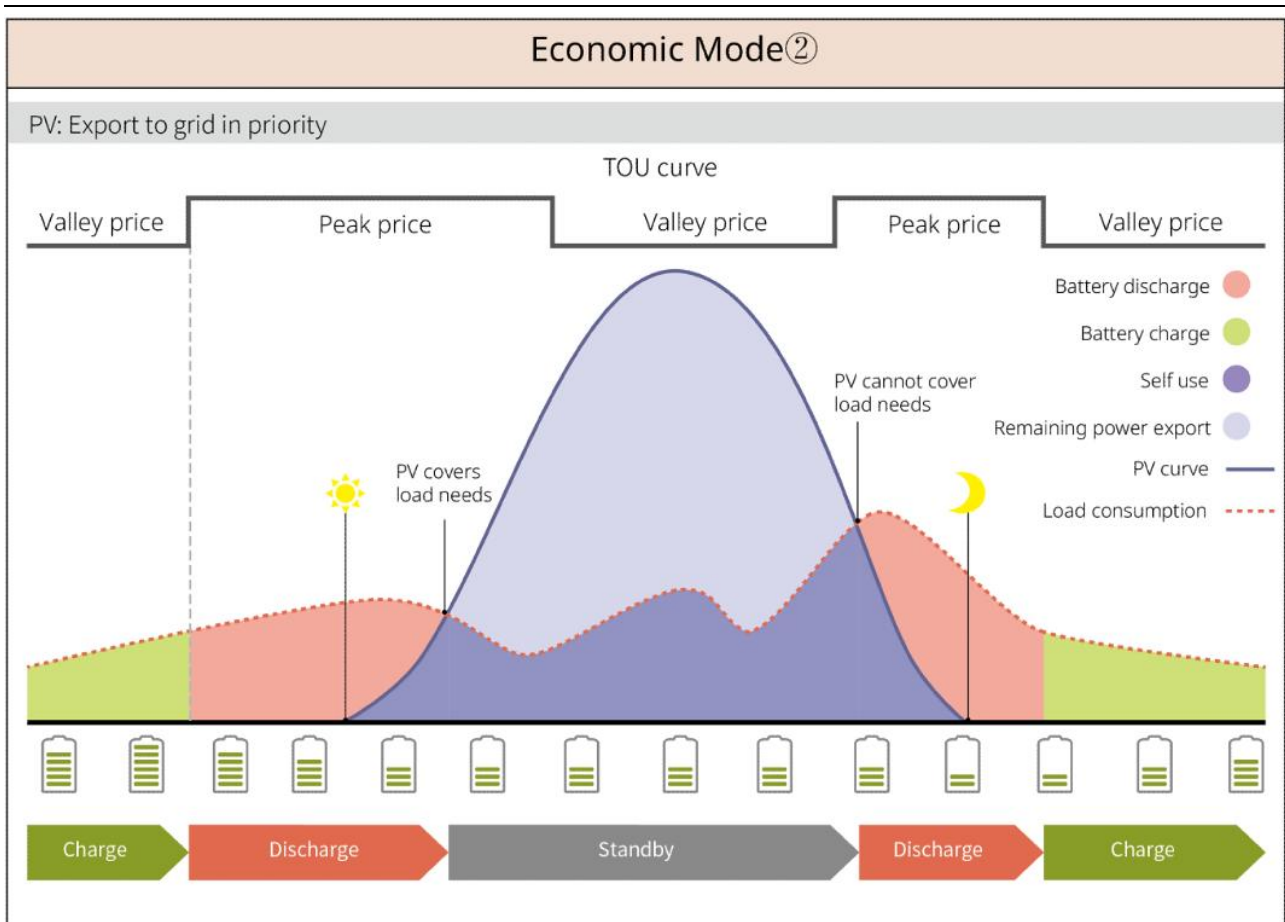

Smart Charging Mode

- In some countries/regions, the PV power feed into the utility grid is limited.
- Set peak limit power, charge the battery using the surplus power when the PV power exceeds the peak limit power. Or set charging time, during the charging time, the PV power can be used to charge the battery.

Smart Charging①

PV > Peak Limit

Switch to Charge: enabled/disabled

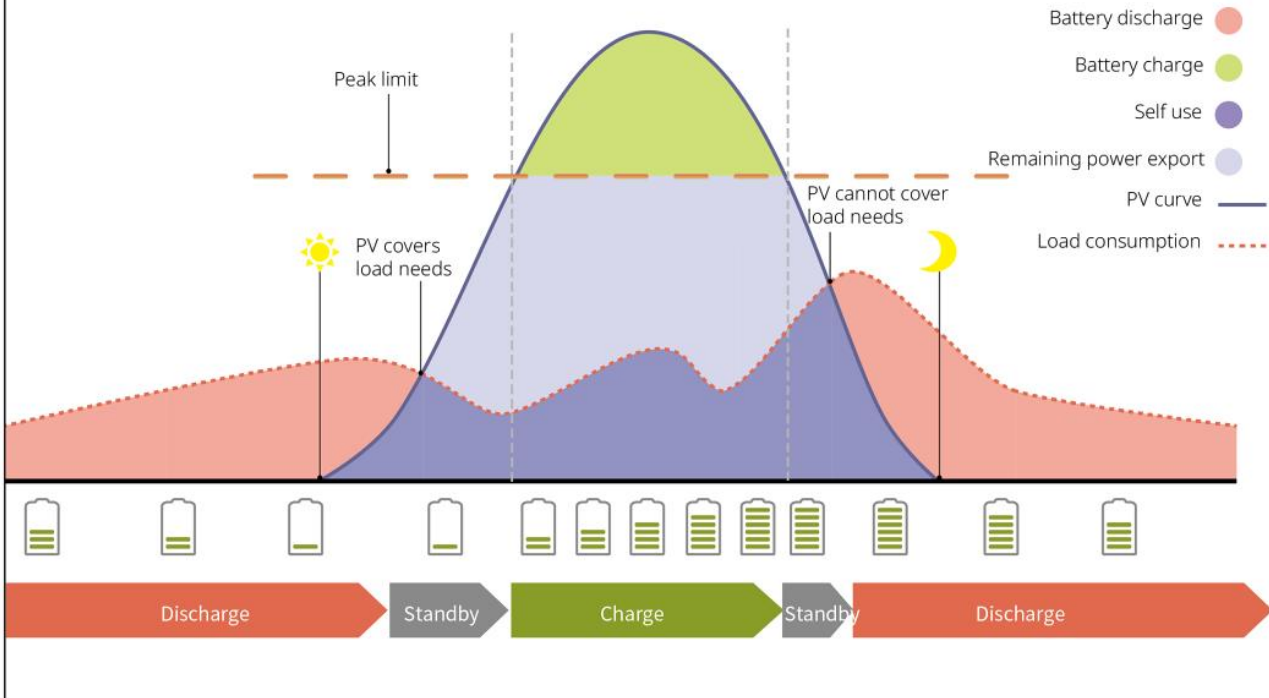

Smart Charging②

PV > Peak Limit

Switch to Charge: enabled/disabled

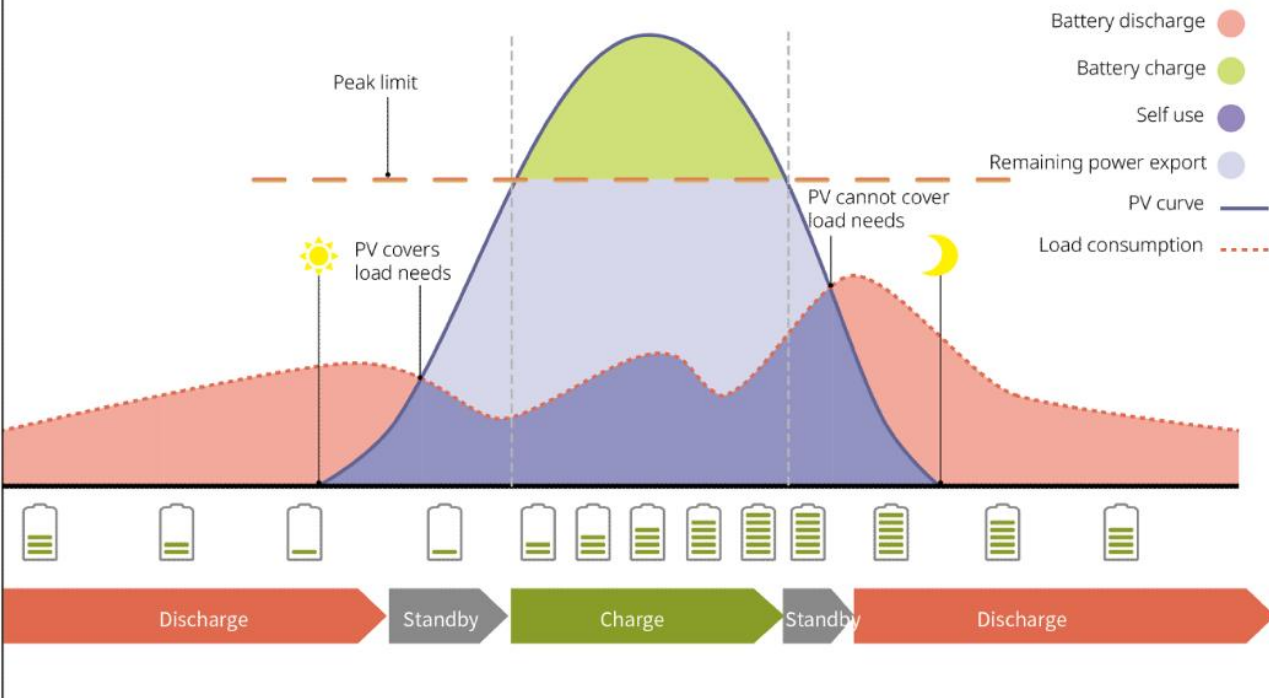

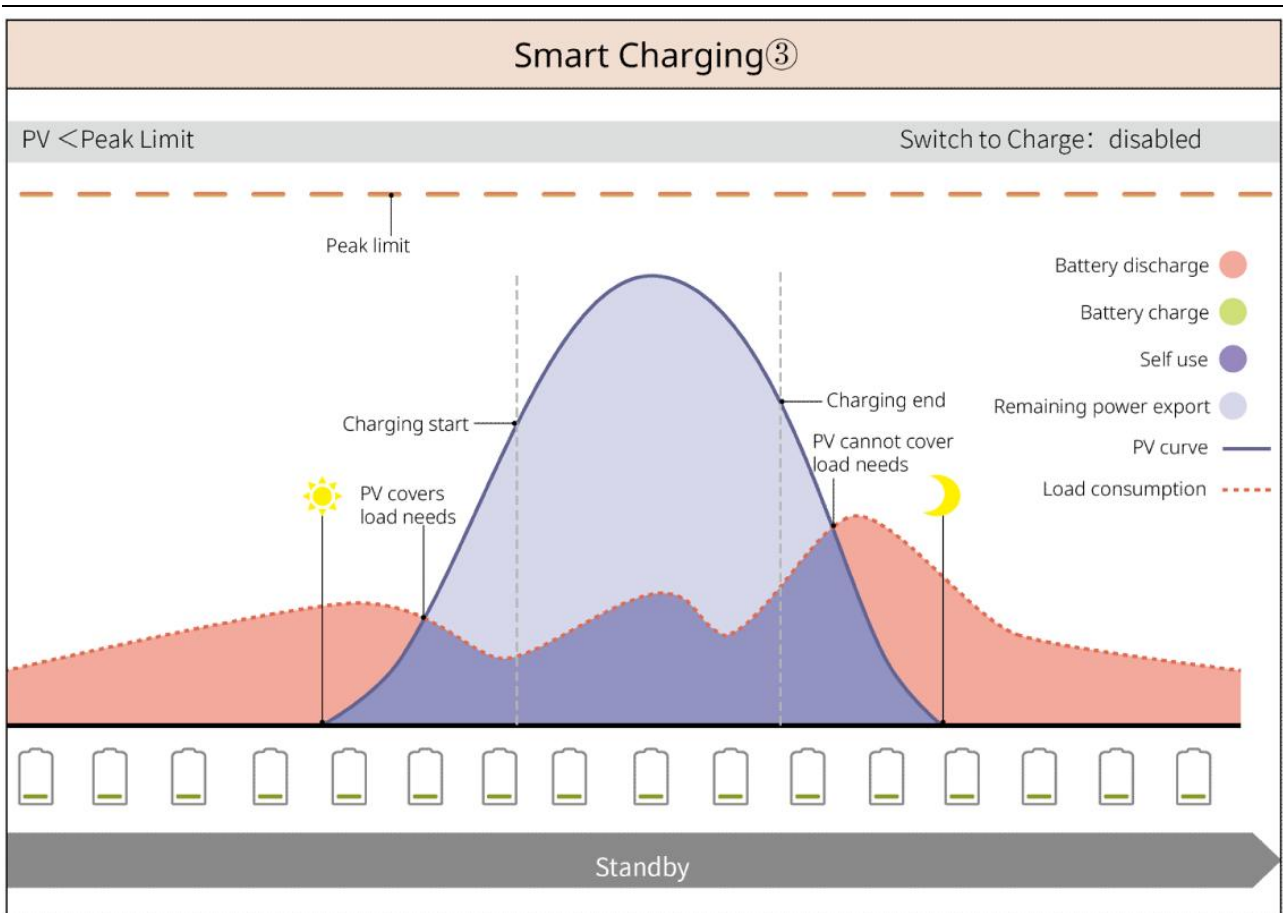

Peakshaving Mode

- Peakshaving mode is mainly applicable to industrial and commercial scenarios.
- When the total power consumption of the loads exceeds the peak shaving limit, the battery discharges to reduce the power consumption exceeds the peak shaving limit.
- If the SOC of the two connected battery systems are lower than the Reserved SOC for Peakshaving, the system will import power from the utility grid according to the set time period, load power, and Import Power Limit. If the SOC of one battery system is lower than the Reserved SOC for Peakshaving, the system will import power from the utility grid according to the load power, and Import Power Limit.

Peakshaving①

BAT1/BAT2 SOC < 80

Reserved SOC For Peakshaving: 80

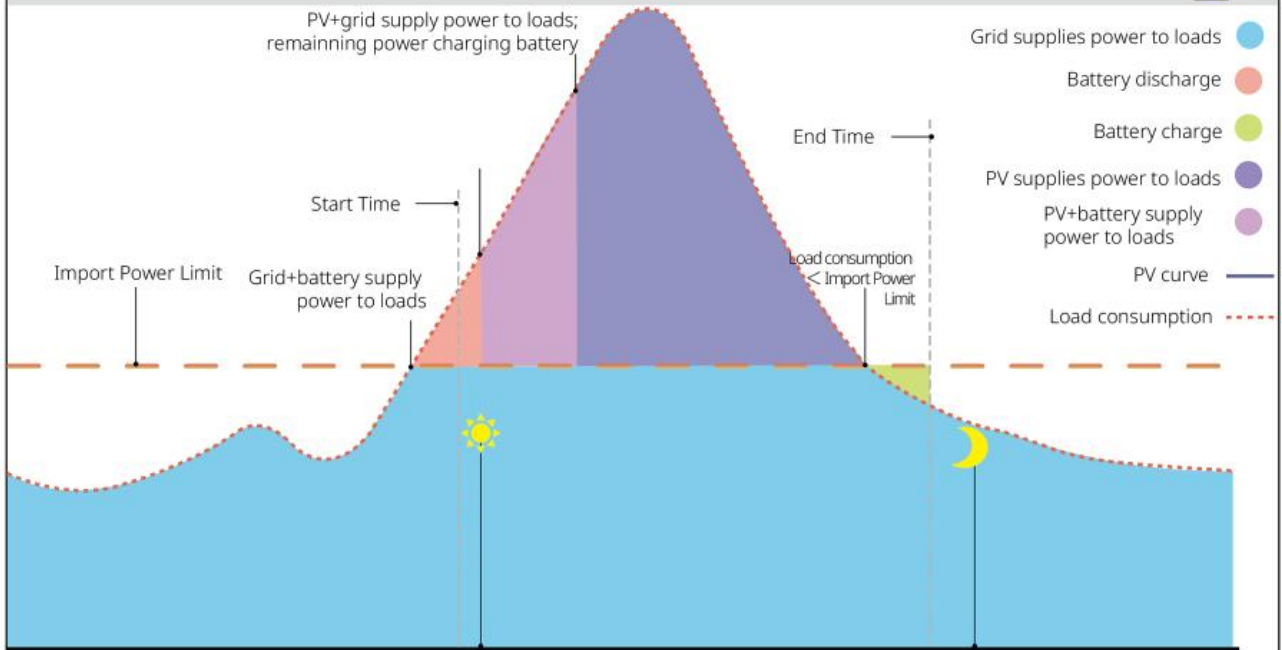

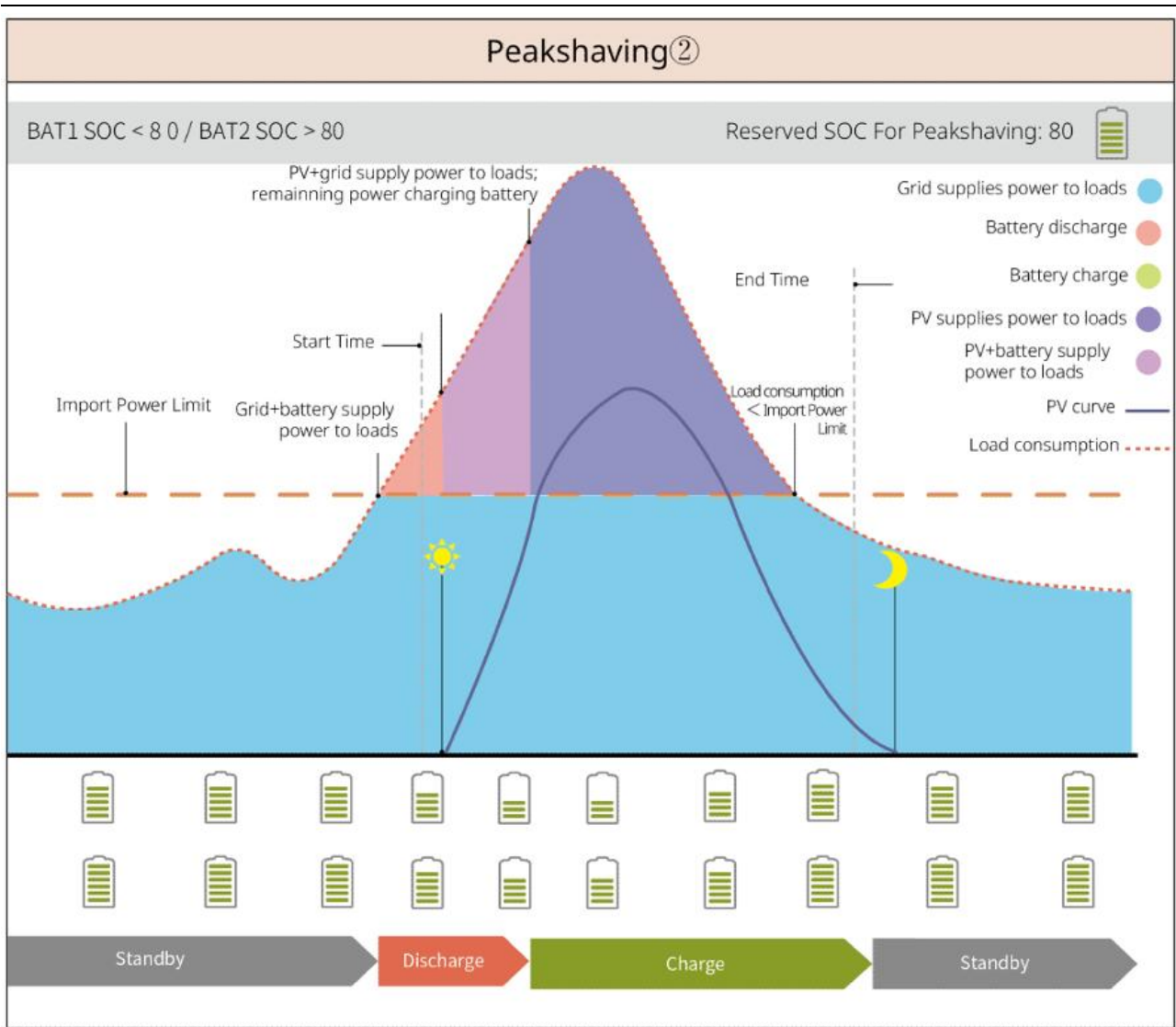

4 Check and Storage

4.1 Check Before Receiving

Check the following items before receiving the product.

1. Check the outer packing box for damage, such as holes, cracks, deformation, and other signs of equipment damage. Do not unpack the package and contact the supplier as soon as possible if any damage is found.
2. Check the product model. If the model is not what you requested, do not unpack the product and contact the supplier.







4.2 Package Content



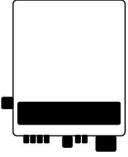
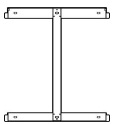
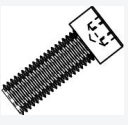
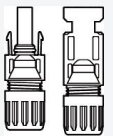
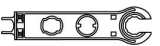
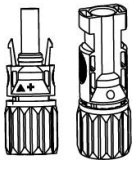

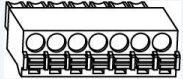
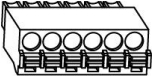
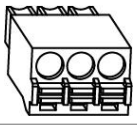
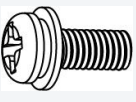
Check the deliverables for correct model, complete contents, and intact appearance. Contact the supplier as soon as possible if any damage is found.

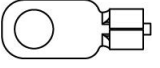
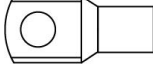
After removing the pack, do not place the deliverables in any rough, uneven or sharp placed to avoid paint loss.

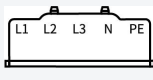
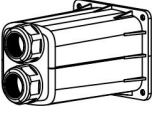
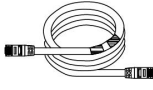
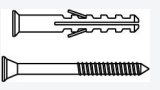
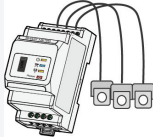
4.2.1 Package of the Inverter (ET 15-30kW)

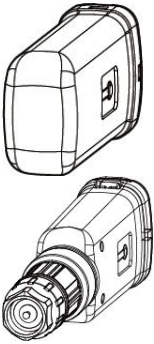







Parts	Quantity	Parts	Quantity
	Inverter x 1		Mounting plate x 1
	Screws for mounting plate x 2		PV connector GW15K-ET, GW20K-ET: 4 GW25K-ET, GW29.9K-ET, GW30K-ET: 6
	PV tool x 1		Battery connector GW15K-ET, GW20K-ET: 1 GW25K-ET, GW29.9K-ET, GW30K-ET: 2
	Battery tool x 1		7PIN terminal x 1
	6PIN terminal x 1		3PIN terminal x 1
	PE screw x 1		PIN terminal x N The pin terminal various depending on different inverters. The actual accessories may differ.
	PE terminal x 1		OT terminal x 12
	Flange nuts for AC terminal x 20		Insulation board for AC terminal x 1
	AC cover x 1		BMS/Meter communication cable: GW15K-ET, GW20K-ET: 2 GW25K-ET, GW29.9K-ET, GW30K-ET: 3
	Expansion bolt x 6		Smart meter and accessories x 1

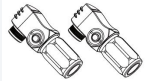
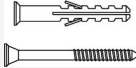
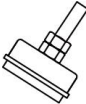

	Smart dongle x 1		Screws driver x 1
	Documents x 1	-	-

4.2.2 Package of the Battery (Lynx Home F series)

4.2.2.1 Lynx Home F, Lynx Home F Plus+

- Power control unit

Parts	Quantity	Parts	Quantity	
	PCU x 1		Base x 1	
	DC connector ● Lynx Home F x 1 ● Lynx Home F Plus+ x 2		Expansion bolt x 4	
Adjustable feet 	<ul style="list-style-type: none"> ● Adjustable feet: only for Lynx home F Plus+ battery. ● Included bracket quantity when adjustable feet is selected: <ul style="list-style-type: none"> ○ Adjustable feet: 4pcs ○ Locking bracket (match adjustable feet): 2pcs ○ Normal locking bracket: 2pcs ● Included bracket quantity when adjustable feet is not selected: <ul style="list-style-type: none"> ○ Normal locking bracket: 4pcs 			
Locking bracket (match adjustable feet) 				
Normal locking bracket 				
	M5*12 screw x 4		M5 hexagon screw x 2	
	M6 screw x 2		Grounding terminal x 2	

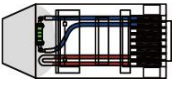



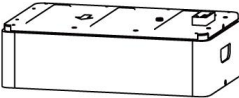

	protective cover x 1		Documents x 1
	Terminal resistor x 1	-	-

- **Battery module**

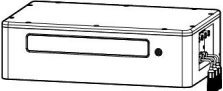
Parts	Quantity
	Battery module x 1

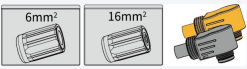
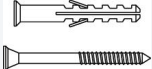
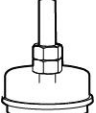
4.2.2.2 Lynx Home F G2

- **Power control unit**

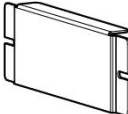
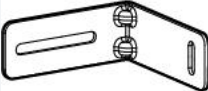
Parts	Quantity	Parts	Quantity
	PCU x 1		Base x 1
	DC connector x 2		Expansion bolt x 8
	Adjustable feet x 4		M5*12 screw x10
	M6 screw x 2		PE terminal x 2
	Documents x 1		Cover plate x 1
	Locking bracket x 8	-	-

- **Battery module**



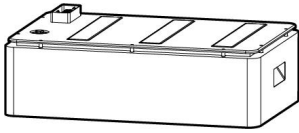



Parts	Quantity
-------	----------



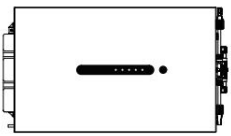
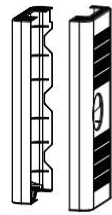

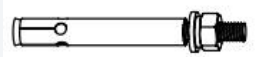

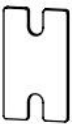



Battery module x 1

4.2.3 Package of the Battery (Lynx Home D)

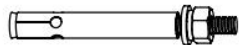
- Battery









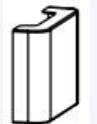

Parts	Quantity	Parts	Quantity
	Battery x 1		protective cover x 2
	M6 screws x 2		M6 expansion bolt x 2
	M5 screws x 4		Locking bracket x 2
	Fixing bracket between batteries x 2		Communication cable between batteries x 1

- (Optional) Base

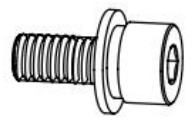
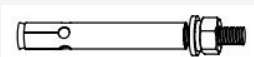
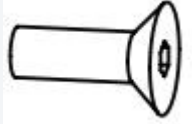
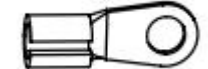





Parts	Quantity	Parts	Quantity
	Base x 1		M5 Screws x 2
	M6 expansion bolt x 2		Fixing bracket between base and battery x 2
	Grounding terminal x 1		Power connector (10mm ²) x 2
	Power connector (6mm ²) x 2		Terminal resistor x 1

	Fastening tool for power connector x 1		Fastening tool for power connector x 1
	Documents x 1	-	-



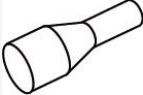

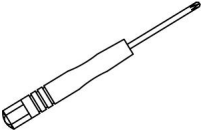
● (Wall mounting rack)

Parts	Quantity	Parts	Quantity
	Wall mounting rack x 1		Front protective cover x 1
	Left protective cover x 1		Right protective cover x 1
	Fixing bracket between rack and battery x 2		M5 screws x 2
	M12 expansion bolt x 4		M4 screws x 5
	Grounding terminal x 1		Terminal resistor x 1
	Power connector (10mm ²) x 2		Power connector (6mm ²) x 2
	Fastening tool for power connector x 1		Fastening tool for power connector x 1
	Documents x 1	-	-

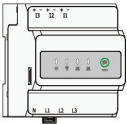
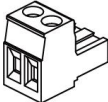

4.2.3 Smart Meter (GM3000)

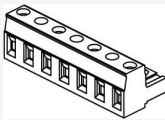
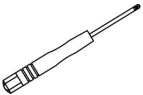
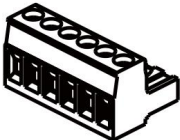
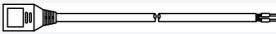
Parts	Quantity	Parts	Quantity
	Smart meter and CT x 1		2PIN-RJ45 adapter cable x 1
	PIN terminal x 3		USB plug x 1
	Screws driver x 1		Documents x 1

4.2.4 Smart Meter (GM330)

Parts	Description	Parts	Description
	Smart meter and CT x 1		2PIN terminal x 1
	PIN terminal x 6		7PIN terminal x 1
	Screw driver x 1		6PIN terminal x 1
	2PIN-RJ45 adapter cable x 1		Documents x 1

4.2.5 Smart Dongle (Wi-Fi Kit)



Parts	Quantity	Parts	Quantity
	Smart dongle x 1		Documents x 1





Unlock tool x 1

Remove the module using the removing tool if it is included. If the tool is not provided, remove the module by pressing the unlock button on the module.

4.2.6 Smart Dongle (WiFi/ LAN Kit-20)

Parts	Description	Parts	Description
	Smart dongle x 1		Documents x 1

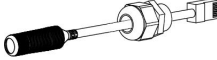
4.2.7 Smart Dongle (Ezlink3000)

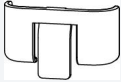
Parts	Description	Parts	Description
	Smart dongle x 1		LAN cable connector x 1
	Documents x 1		Unlock tool x 1 Remove the module using the removing tool if it is included. If the tool is not provided, remove the module by pressing the unlock button on the module.

4.3 Storage

If the equipment is not to be installed or used immediately, please ensure that the storage environment meets the following requirements: If the equipment has been long term stored, it should be checked by professionals before being put into use.

Packing requirements:

Do not unpack the outer package or throw the desiccant away.

Installation environment requirements:

1. Place the equipment in a cool place where away from direct sunlight.
2. Store the equipment in a clean place. Make sure the temperature and humidity are appropriate and no condensation. Do not install the equipment if the ports or terminals are condensed.

Battery storage temperature range (T):

- When $-20^{\circ}\text{C} \leq T < 0^{\circ}\text{C}$ or $35^{\circ}\text{C} < T \leq 45^{\circ}\text{C}$, the storage period cannot exceed 1 month.
- When $0^{\circ}\text{C} \leq T \leq 35^{\circ}\text{C}$, the storage period cannot exceed 1 year.

3. Keep the equipment away from flammable, explosive, and corrosive matters.

Stacking requirements:

1. The height and direction of the stacking inverter should follow the instructions on the packing box.
2. The inverter must be stacked with caution to prevent them from falling.

Battery Dis-/Charge Requirements:

Storage SOC: 25%-50% SOC. Circle the charge-discharge every 6 months.

5 Installation



Install and connect the equipment using the deliverables included in the package. Otherwise, the manufacturer shall not be liable for the damage.

5.1 System Installation and Commissioning Procedure

Steps	1 Installation	2 PE	3 PV	4 Battery	5 AC	6 COM	7 Communication module					
Inverter							Wi-Fi Kit	WiFi/LAN Kit-20	Ezlink3000			
Tools	1 D: 80mm φ: 8mm 2 M5 1.2-2N·m	M5 1.2-2N·m	Recommend: PV-CZM-61100	Recommend: YQK-70	1 M5 2-3N·m 2 M6 3-4N·m							
Steps	1 Installation				2 PE	3 Battery				4 COM		
Battery	Lynx Home F (G2)	Lynx Home F (G1)	Lynx Home F (G1 Plus+)	Lynx Home D	Lynx Home F	Lynx Home D	Lynx Home F (G2)	Lynx Home F (G1)	Lynx Home F (G1 Plus+)	Lynx Home D	Lynx Home F	Lynx Home D
Tools					M6 6-7N·m	M5 4N·m	Recommend: YQK-70	Recommend: YQK-70	Recommend: YQK-70	Recommend: YQK-70		
Steps	1 Installation		2 Cable Connections		3 Power	4 Commissioning						
Smart meter	GM3000	GM330	GM3000	GM330	AC breaker		SolarGo APP					
							SEMS Portal APP or SEMS Portal WEB					

5.2 Installation Requirements

5.2.1 Installation Environment Requirements

1. Do not install the equipment in a place near flammable, explosive, or corrosive materials.
2. The temperature and humidity at the installation site should be within the appropriate range.
3. Do not install the equipment in a place that is easy to touch, especially within children's reach.
4. 60°C high temperature exists when the equipment is working. Do not touch the surface to avoid burning.
5. Install the equipment in a sheltered place to avoid direct sunlight, rain, and snow. Build a sunshade if it is needed.
6. The inverter output power may decrease due to direct sunlight or high temperature.

-
7. The place to install the equipment shall be well-ventilated for heat radiation and large enough for operations.
 8. Check the protection rating of the equipment and ensure that the installation environment meets the requirements. The inverter, battery system, and smart dongle can be installed both indoors or outdoors. But the smart meter can only be installed indoors.
 9. Install the equipment at a height that is convenient for operation and maintenance, electrical connections, and checking indicators and labels.
 10. The altitude to install the equipment shall be lower than the maximum working altitude of the system.
 11. Consult the manufacturer before installing the equipment outdoors in salt affected areas. A salt affected area refers to the region within 500 meters offshore, and will be related to the sea wind, precipitation and topography.
 12. Install the equipment away from electromagnetic interference. If there are radio stations or wireless communication equipment below 30 MHz near the installation location, please install the equipment as follows:
 - Inverter: add a multi-turn winding ferrite core at the AC output cable of the inverter, or add a low-pass EMI filter.
 - Other equipment: the distance between the equipment and the wireless EMI equipment should be more than 30m.

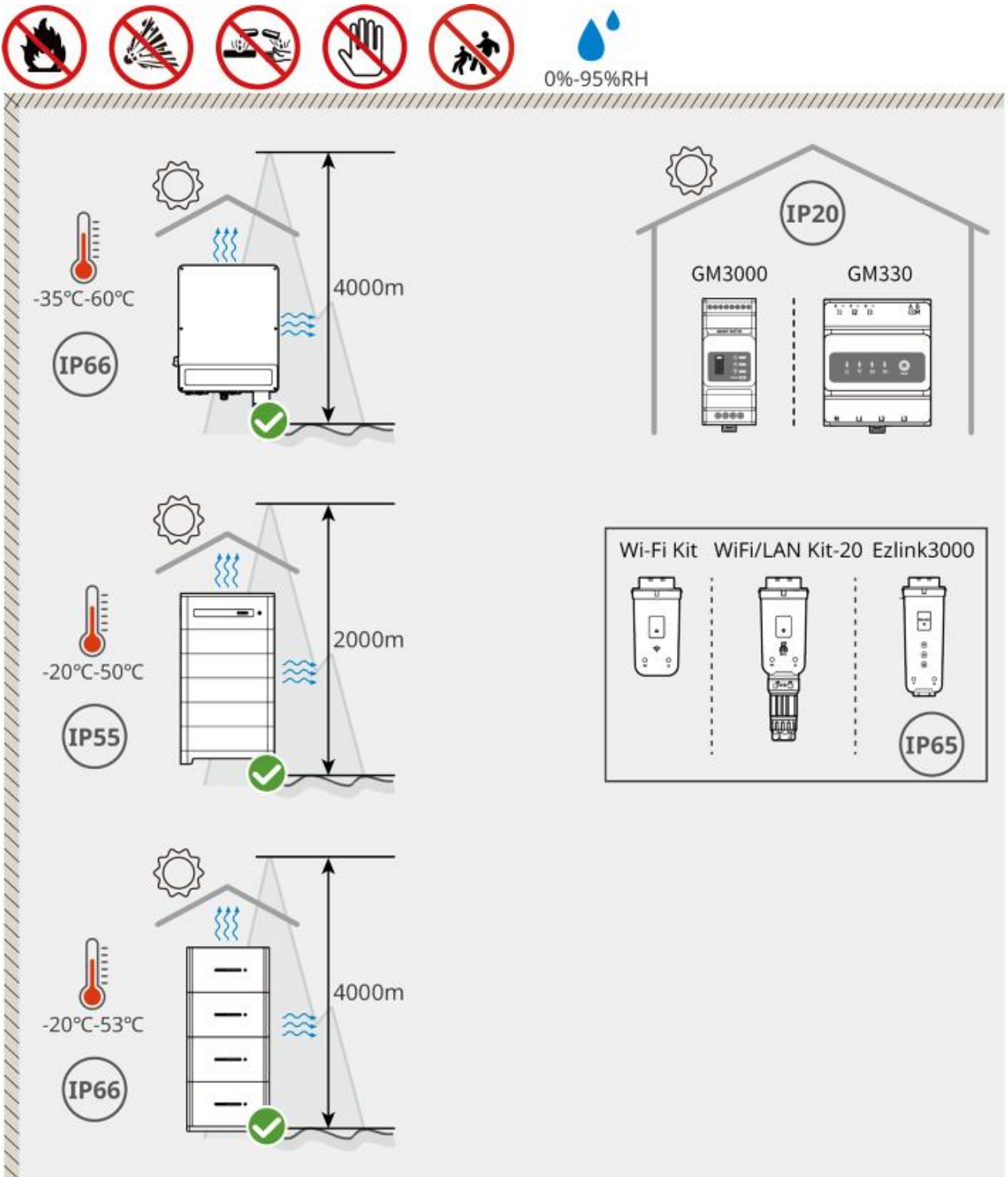

ET3010INT0001

5.2.2 Installation Space Requirements

Reserve enough space for operations and heat dissipation when installing the system.

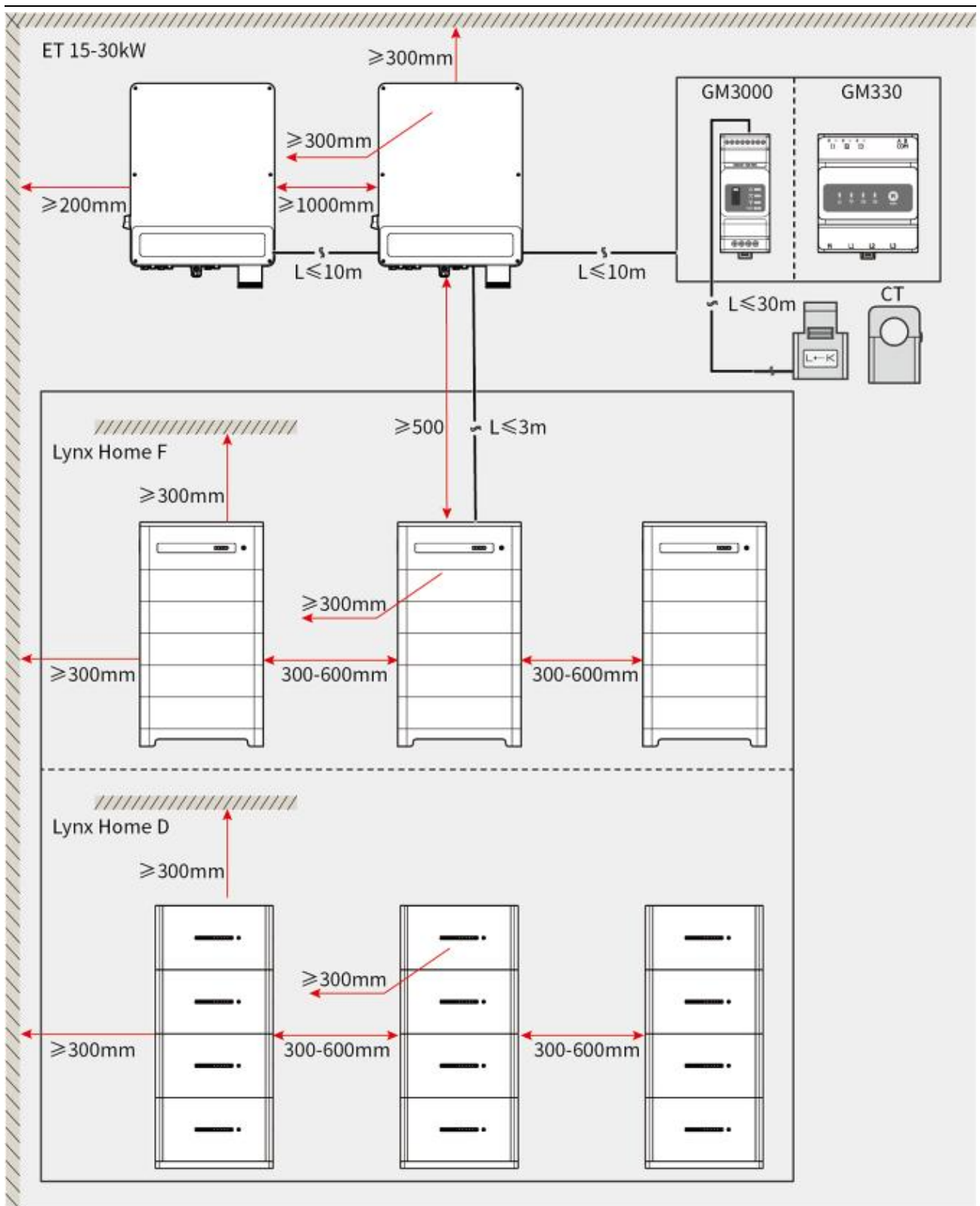

ET3010DSC0002

5.2.3 Tool Requirements

NOTICE



The following tools are recommended when installing the equipment. Use other auxiliary tools on site if necessary.

Installation Tools

Tool	Description	Tool	Description
	Diagonal pliers		RJ45 crimping tool
	Wire stripper		YQK-70 hydraulic pliers
	Adjustable wrench		PV connector tool PV-CZM-61100
	Hammer drill (Φ8mm)		Torque wrench M5/M6/M8
	Rubber hammer		Socket wrench set
	Marker		Multimeter Range ≤ 1100V
	Heat shrink tube		Heat gun
	Cable tie		Vacuum cleaner
	Level	-	-

Personal Protective Equipment

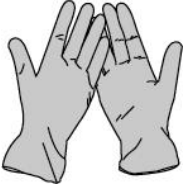
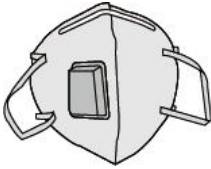
Tool	Description	Tool	Description
------	-------------	------	-------------

	Insulation gloves and safety gloves		Dust mask
	Goggles		Safety shoes

5.2.4 Transportation Requirements

WARNING

- Operations such as transportation, turnover, installation and so on must meet the requirements of local laws and regulations.
- Move the equipment to the site before installation. Follow the instructions below to avoid personal injury or equipment damage.
 1. Consider the weight of the equipment before moving it. Assign enough personnel to move the equipment to avoid personal injury.
 2. Wear safety gloves to avoid personal injury.
 3. Keep balance to avoid falling down when moving the equipment.

5.3 Installing the Inverter

CAUTION

- Avoid the water pipes and cables buried in the wall when drilling holes.
- Wear goggles and a dust mask to prevent the dust from being inhaled or contacting eyes when drilling holes.
- Make sure the inverter is firmly installed in case of falling down.

Step 1: Put the plate on the wall horizontally and mark positions for drilling holes.

Step 2: Drill holes with the hammer drill.

Step 3: Use the expansion bolts to fix the inverter on the wall.

Step 4: (Optional) Secure the DC switch with the DC switch lock, ensuring that the DC switch is OFF during installation. Install the inverter on the mounting plate. The DC switch lock of appropriate size should be prepared by customers.

Step 5: (Optional) Put the handles down.

Step 6: Tighten the nuts to secure the mounting plate and the inverter.

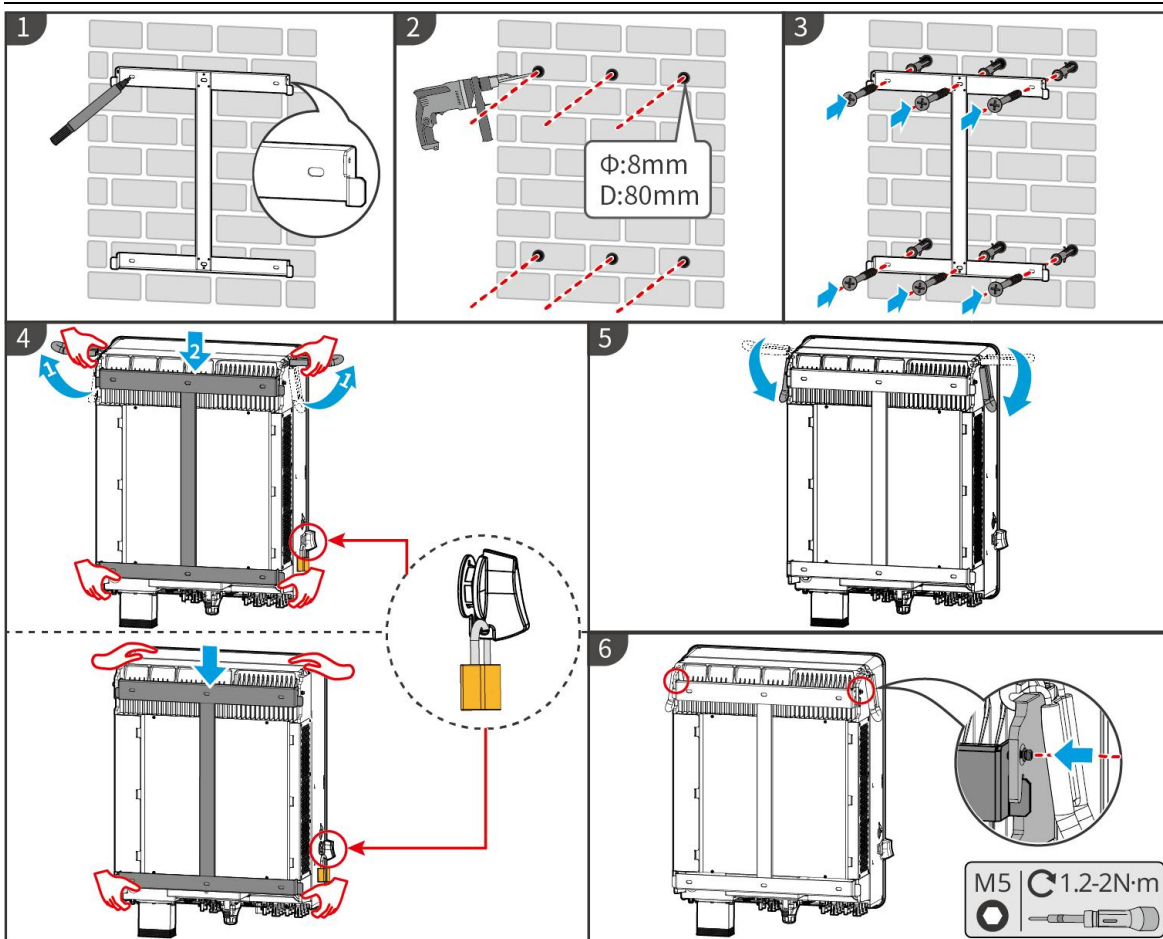

ET3010INT0002

5.4 Installing the Battery System

5.4.1 Installing Lynx Home F

WARNING

- Ensure that the PCU is installed above the battery modules. Do not install any battery modules above the PCU.
- Ensure that the battery system is installed vertically and securely. Align the installation holes of the battery base, battery modules, and PCU. Ensure that the locking bracket clings to the ground, wall or battery system.
- Cover the equipment with a cardboard to prevent foreign matters when drilling holes. Otherwise, the system may be damaged.
- Remove the protective cover on the connection part of the battery system before installation.
- Remove the cover of the battery module's connection port before installing the battery system.

Step 1 Install the locking bracket to the base.

Step 2 Place the base cling to the wall and mark the drilling positions. Then remove the base.

Step 3 Drill holes with the hammer drill.

Step 4 Screw the expansion bolts to fix the base. Ensure that the base is installed in the correct direction.

Step 5 Remove the protective cover of the blind-mate connector.

Step 6 Place the battery module on the base, and ensure that the base and the battery are installed in the same direction. Install the remaining batteries and PCU based on the actual needs.

Step 7 Preinstall the locking bracket to the PCU.

Step 8 Put the PCU above the installed battery module securely. Mark the drilling hole using a marker, then remove the PCU.

Step 9 Drill holes with the hammer drill.

Step 10 Secure the locking bracket to the wall.

Step 11 Install the locking bracket to PCU.

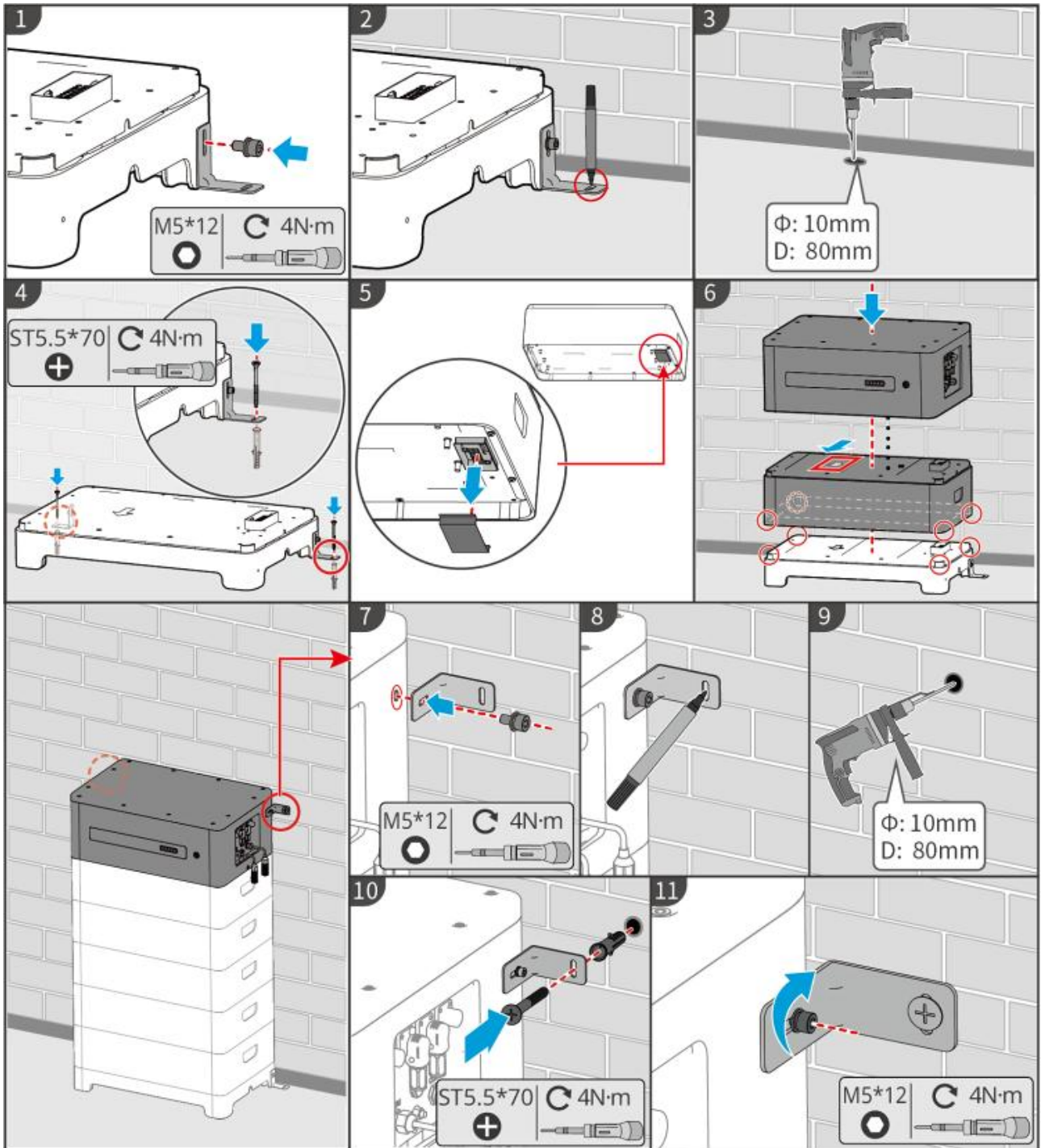

LXF10INT0002

5.4.2 Installing Lynx Home F Plus+

Step 1(Optional) Install the adjustable feet to the base.

Step 2 Install the locking bracket to the base.

Step 3 Place the base cling to the wall and mark the drilling positions. Then remove the base.

Step 4 Drill holes with the hammer drill.

Step 5 Screw the expansion bolts to fix the base. Ensure that the base is installed in the correct direction.

Step 6 Remove the protective cover of the blind-mate connector.

Step 7 Place the battery module on the base, and ensure that the base and the battery are installed in the same direction. Install the remaining batteries and PCU based on the actual needs.

Step 8 Preinstall the locking bracket to the base.

Step 9 Put the PCU above the installed battery module securely. Mark the drilling hole using a marker, then remove the PCU.

Step 10 Drill holes with the hammer drill.

Step 11 Secure the locking bracket to the wall.

Step 12 Install the locking bracket to PCU.

Step 13 (Optional) Check the battery system to ensure that it is installed vertically and securely. In case of tilting or shaking, the battery system can be adjusted by rotating the adjust feet.

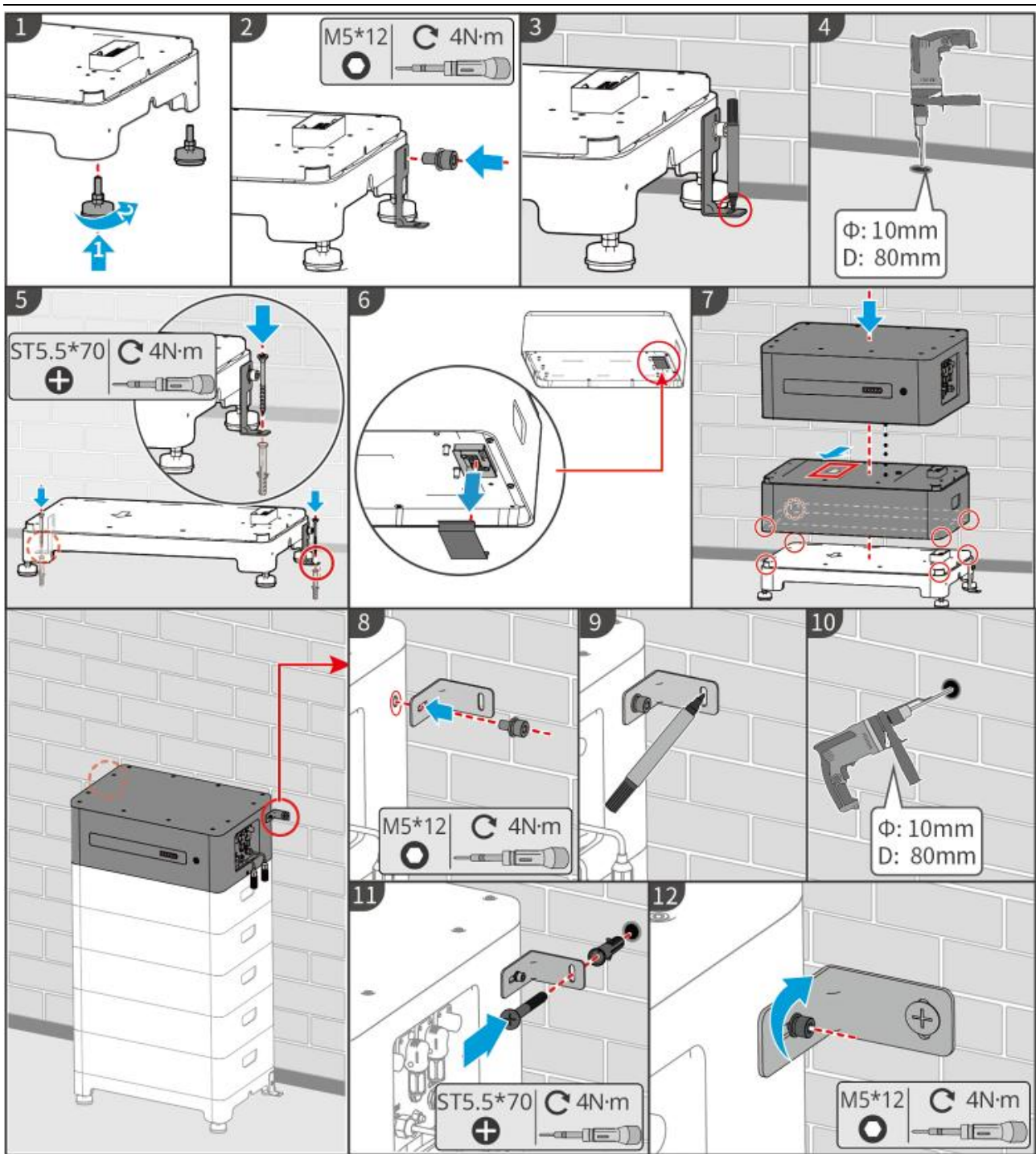

LXF10INT0003

5.4.3 Installation Lynx Home F G2

Step 1(Optional) Install the adjustable feet to the base.

Step 2 Install the locking bracket to the base.

Step 3 Place the base cling to the wall and mark the drilling positions. Then remove the base.

Step 4 Drill holes with the hammer drill.

Step 5 Screw the expansion bolts to fix the base. Ensure that the base is installed in the correct direction.

Step 6 Place the battery module on the base, and ensure that the base and the battery are installed in the same direction. Install the remaining batteries and PCU based on the actual needs.

Step 7 Install the locking bracket of the PCU.

Step 8 Put the PCU above the installed battery module securely. Mark the drilling hole using a marker, then remove the PCU.

Step 9 Drill holes with the hammer drill.

Step 10 Secure the locking bracket to prevent the PCU from falling down.

Step 11 (Optional) Check the battery system to ensure that it is installed vertically and securely. In case of tilting or shaking, the battery system can be adjusted by rotating the adjust feet.

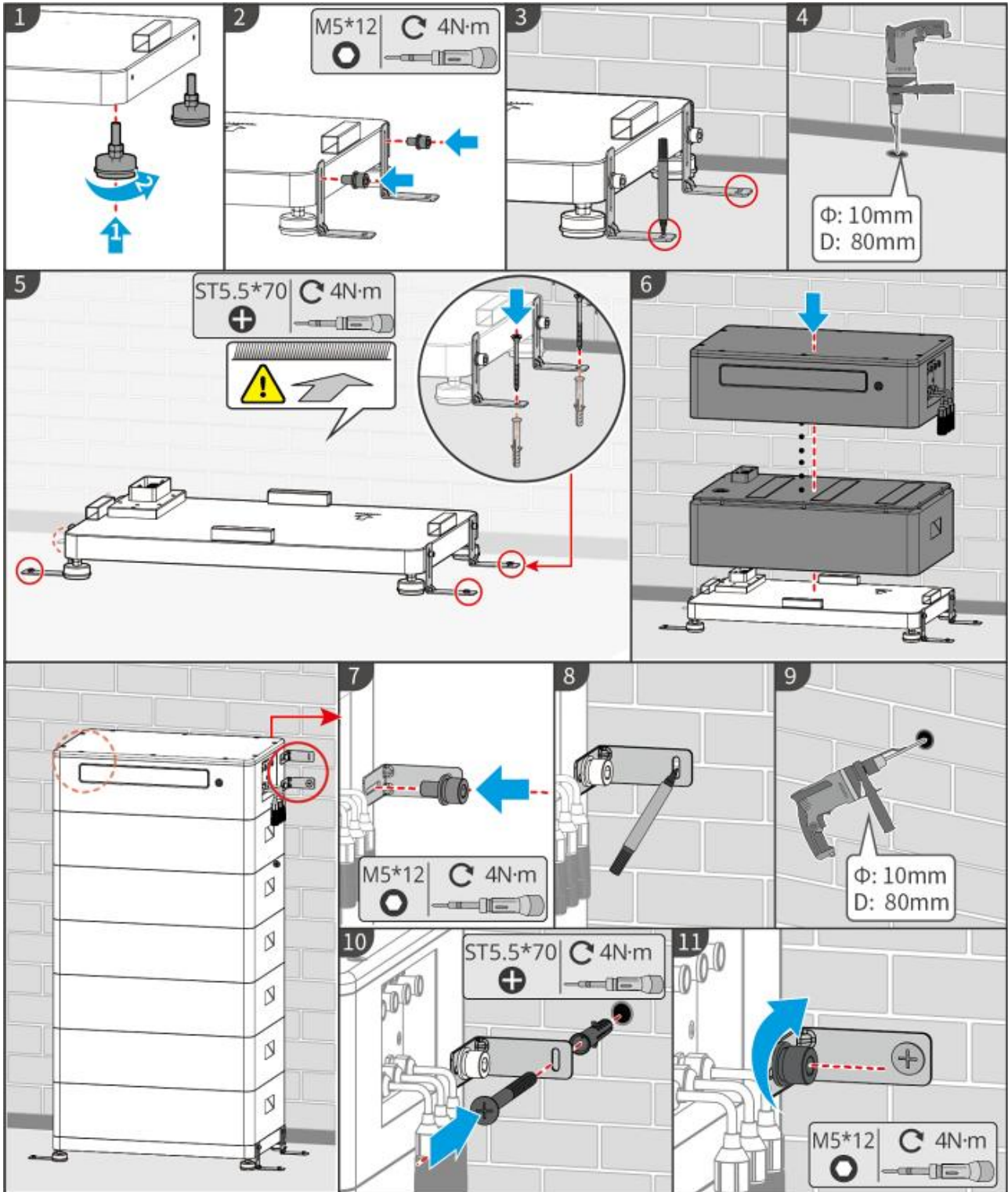

LXF20INT0002

5.4. Installing Lynx Home D

NOTICE

- The battery system can be installed on a base or on a wall mount rack.
- When stacking batteries, auxiliary tools need to be used for installation.
- When a single group of battery exceeds 3 pieces, it is recommended to use a base installation.

Installing the Wall Mounting Rack (Optional)

Step 1 Make the wall mount rack tightly adhere to the wall. Ensure that the rack is securely placed and use a level bar to measure if the rack is level.

Step 2 After adjusting the position and levelness of the rack, mark the drilling positions, then remove the rack.

Step 3 Drill holes and install expansion bolt.

1. Drill holes with the hammer drill.
2. Clean the hole.
3. Use a rubber hammer to install the expansion screw into the hole.
4. Use an external hex wrench to tighten the nut clockwise to expand the screw.
5. Rotate the nut counterclockwise to remove it.

Step 4 Use external hex wrench to install the rack on the wall.

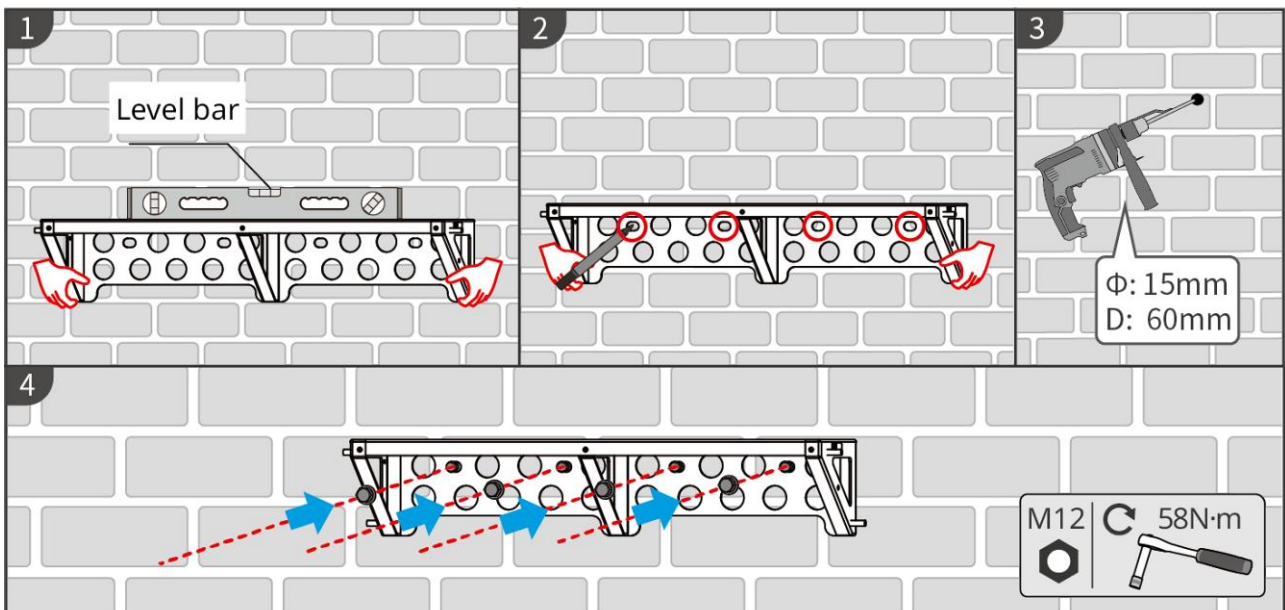

LXD20INT0001

Installing the Base (Optional)

Place the base 5-20mm away from the wall, parallel to the wall, and ensure that the ground is level.

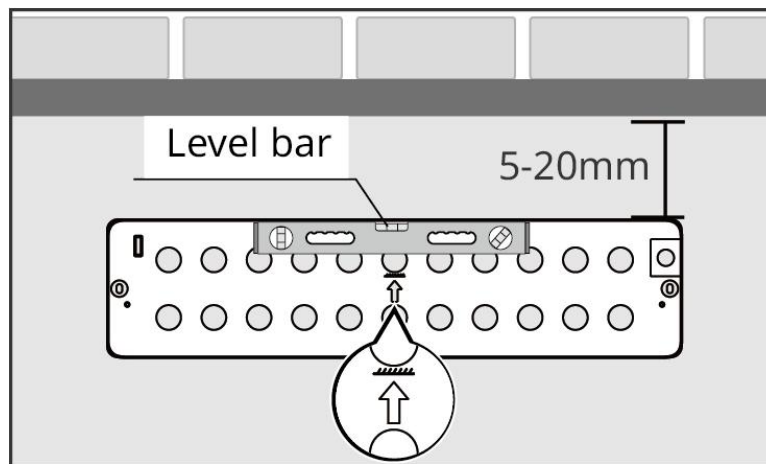

LXD20INT0002

Installing the Battery

Step 1 Preinstall the locking bracket to PCU.

Step 2 Place the battery on the installed rack or base. Place the locking bracket tightly against the wall and mark the drilling position.

When installing the battery using the base, ensure that the left side of the battery is tightly against the limit block on the base.

Step 3 Mark the drilling position, then remove the battery.

Step 4 Drill holes and install expansion bolts.

1. Drill holes with the hammer drill.
2. Clean the hole.
3. Use a rubber hammer to install the expansion screw into the hole.
4. Use an external hex wrench to tighten the nut clockwise to expand the screw.
5. Rotate the nut counterclockwise to remove it.

Step 5 Reinstall the battery on the base or rack, and adjust the battery position to make it 5-20mm away from the wall.

Step 6 Use an external hex wrench to secure the battery to the wall, and use a torque screwdriver to secure the locking bracket to the battery.

Step 7 If multiple batteries need to be installed, please repeat steps 1 to 6 to complete all battery installations.

Step 8 Use locking brackets to secure the battery to the base or rack and then secure the batteries in sequence.

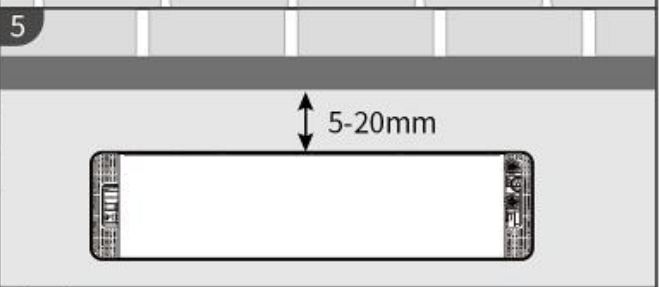
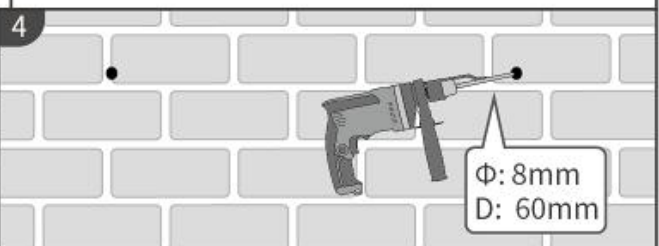
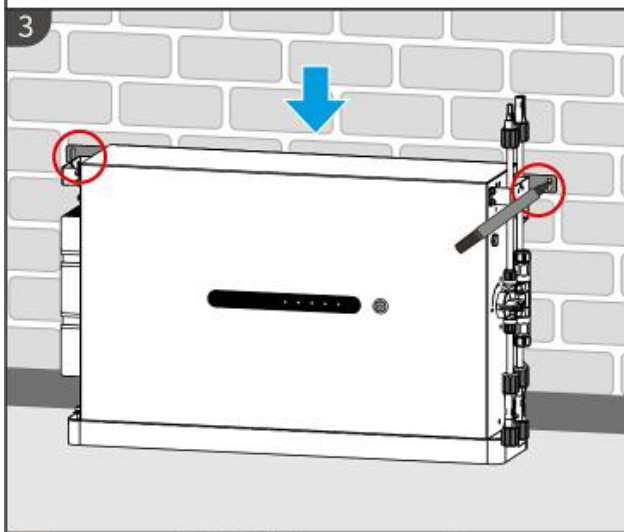
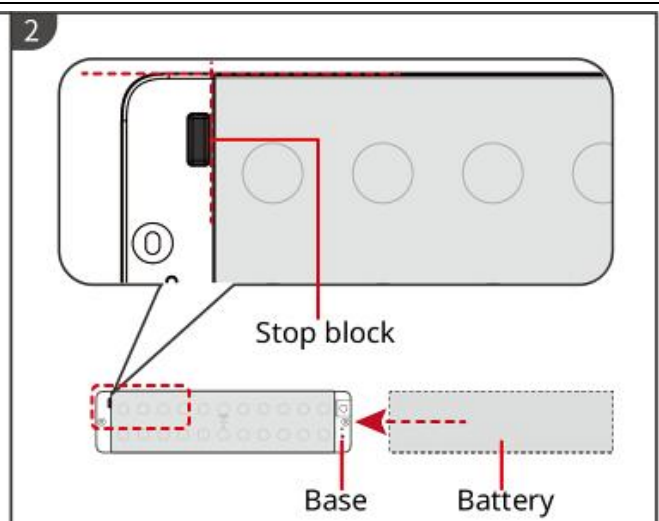
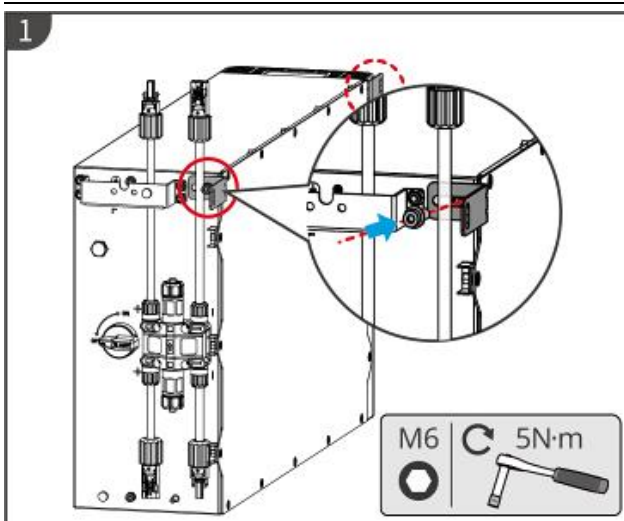

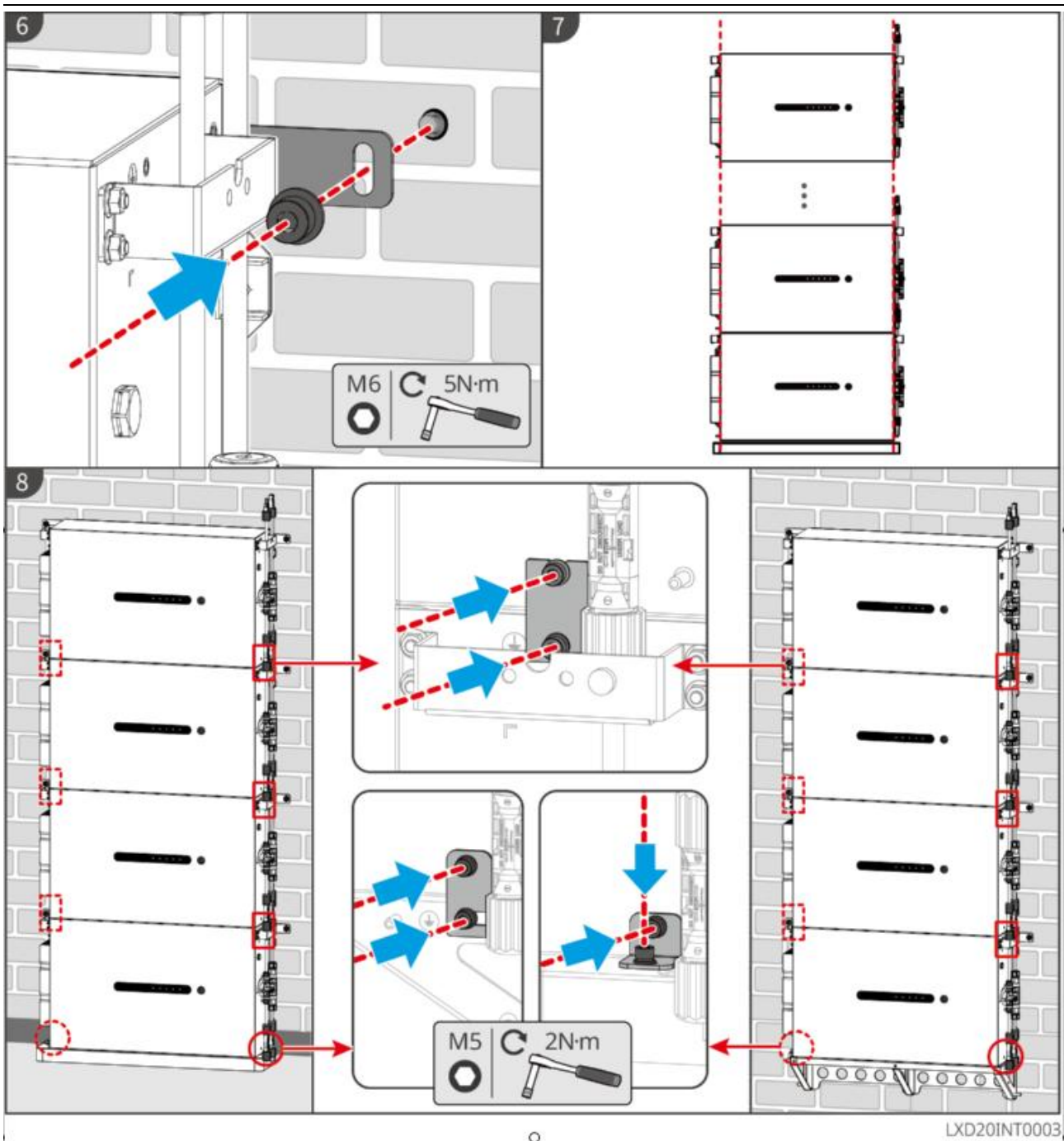

LXD20INT0003

5.5 Installing the Smart Meter



WARNING

In areas at risk of lightning, if the meter cable exceeds 10m and the cables are not wired with grounded metal conduits, you are recommended to use an external lightning protection device.

GM3000

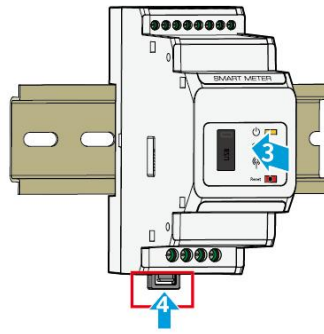
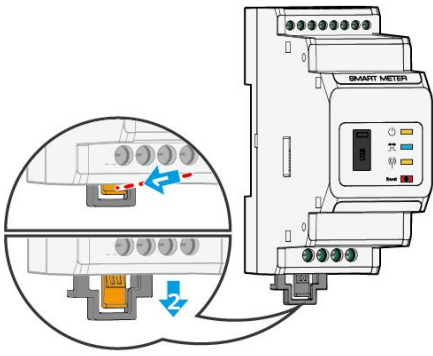

GMK10INT002

GM330

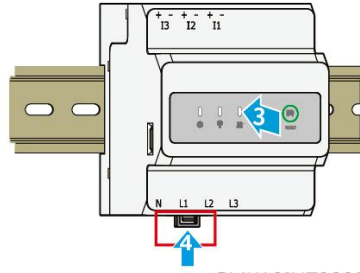
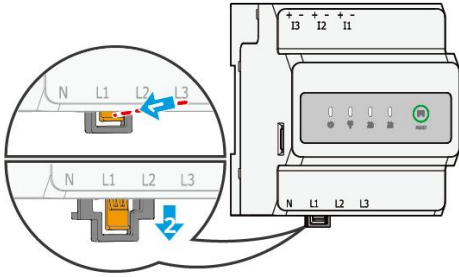

GMK10INT003

6 System Wiring

DANGER

- Perform electrical connections in compliance with local laws and regulations. Including operations, cables, and component specifications.
- Disconnect the DC switches and the AC output switches to power off the equipment before any electrical connections. Do not work with power on. Otherwise, an electric shock may occur.
- Tie the same type cables together, and place them separately from cables of different types. Do not place the cables entangled or crossed.
- If the cable bears too much tension, the connection may be poor. Reserve a certain length of the cable before connecting it to the Inverter cable port.
- Ensure the cable conductor is in full contact with the terminals during crimping. Do not crimp the cable jacket with the terminal. Otherwise the equipment may not be able to operate, or its terminal block getting damaged due to heating and other phenomenon because of unreliable connection after operation.

NOTICE

- Wear personal protective equipment like safety shoes, safety gloves, and insulating gloves during electrical connections.
- All electrical connections should be performed by qualified professionals.
- Cable colors in this document are for reference only. The cable specifications shall meet local laws and regulations.
- For parallel systems, Follow the safety precautions in the user manuals of related products in the system.

6.1 System Wiring Diagram

NOTICE

- N and PE wiring via ON-GRID and BACK-UP ports of the inverter are different based on the regulation requirements of different regions. Refer to the specific requirements of local regulations.
- There are built-in relays inside of the inverter's ON-GRID and BACK-UP AC ports. When the inverter is in the off-grid mode, the built-in ON-GRID relay is open; while when the inverter is in grid-tied mode, it is closed.
- When the inverter is powered on, the BACK-UP AC port is charged. Power off the inverter first if maintenance is required for the loads connected with BACK-UP ports. Otherwise, it may cause electric shock.

N and PE cables are connected together in the Main Panel for wiring.

NOTICE

- To maintain neutral integrity, the neutral cable of ON-GRID side and BACK-UP side must be connected together, otherwise BACK-UP function will not work.
- The following diagram is applicable to areas in Australia and New Zealand.

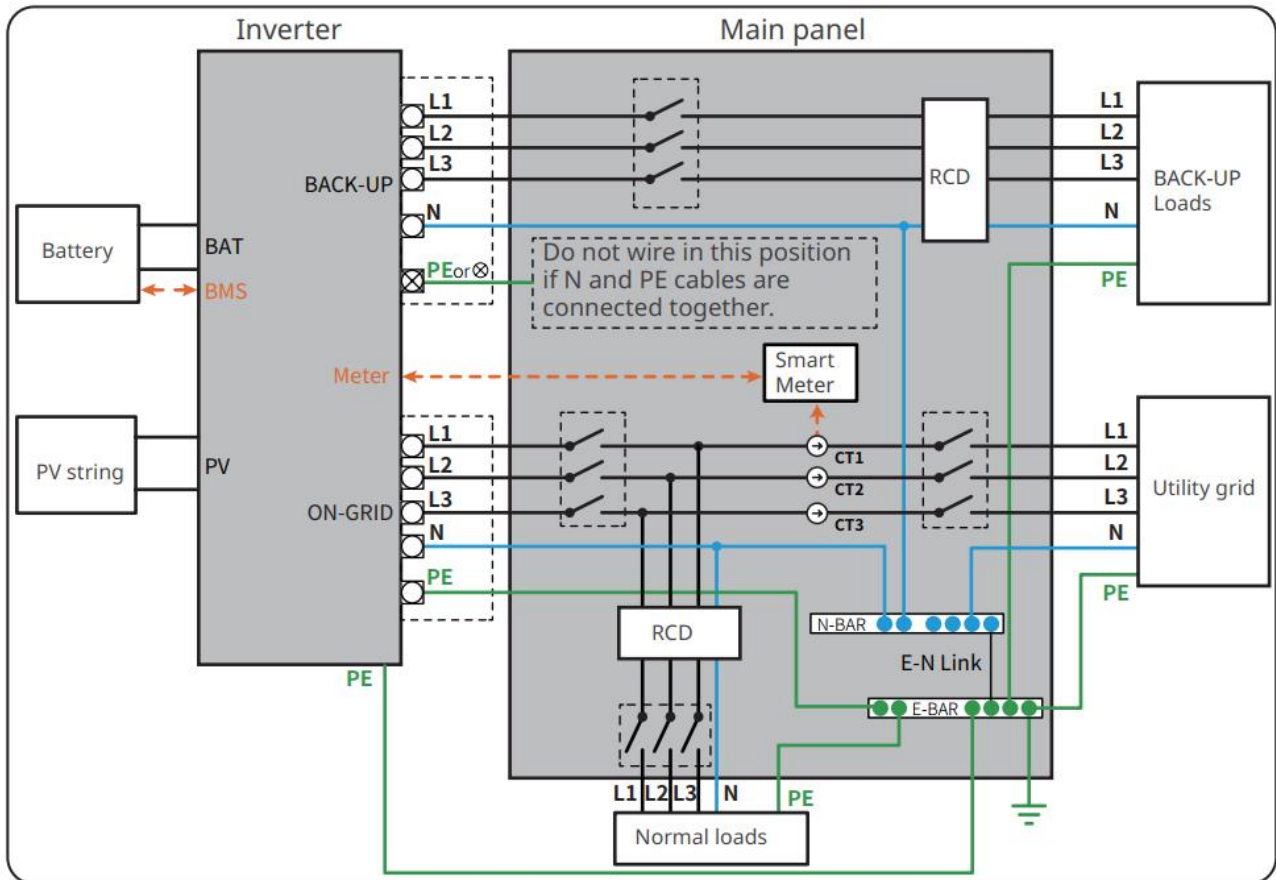

N and PE cables are separately wired in the Main Panel.

NOTICE

- Ensure that the grounding of BACK-UP is correctly and tightened. Otherwise, the BACK-UP function may be abnormal in case of grid failure.
- The following diagram is applicable to areas except Australia or New Zealand.
- In Germany, the internal relay will automatically connect the N wire and PE cable in back-up mode within 100ms and automatically disconnect in on-grid mode.
- In areas other than Germany, the internal relay is disconnected by default in either mode.

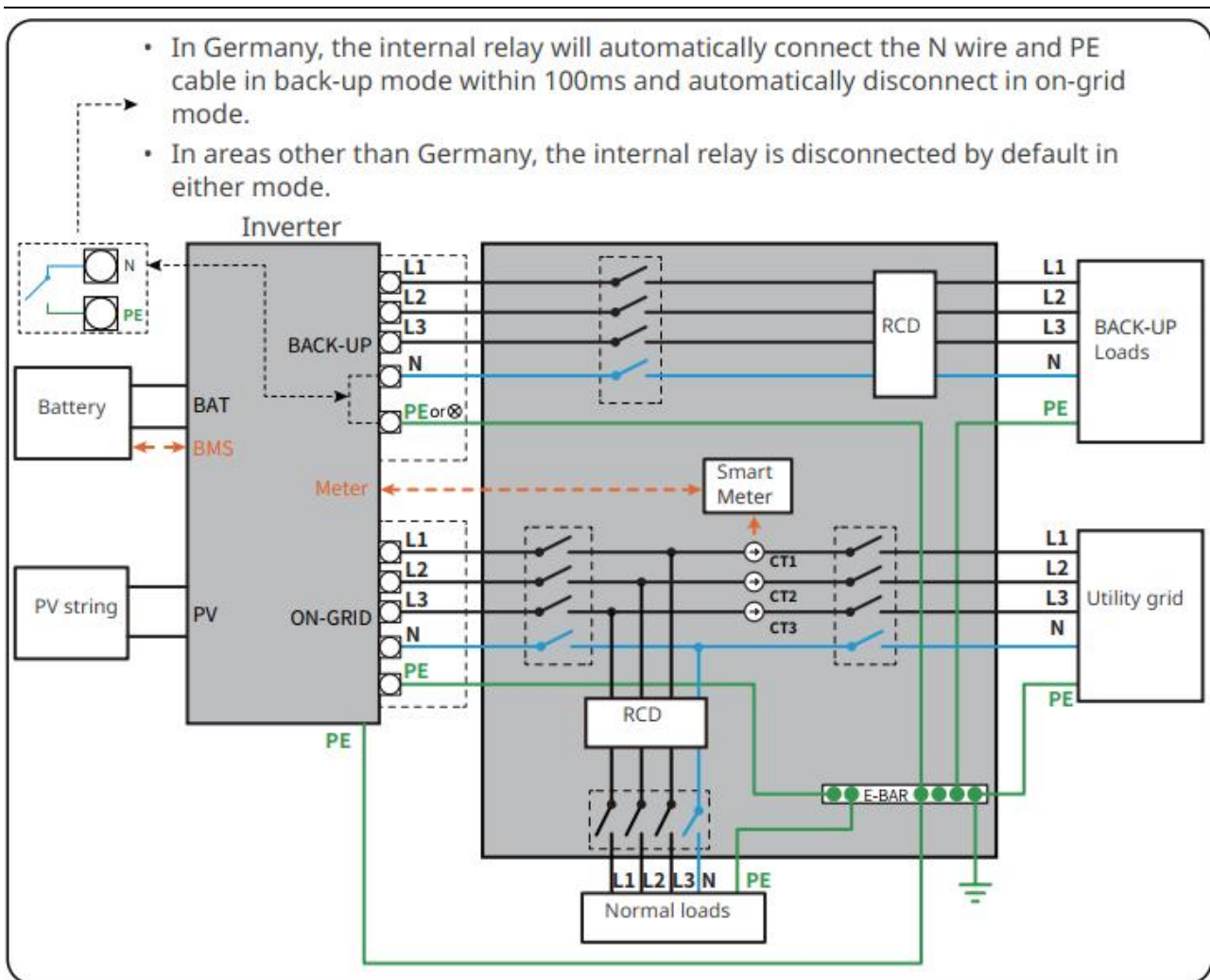

6.2 Detailed System Wiring Diagram

The system wiring diagram takes some models as an example, refer to the electrical connection section and actual used products for more detailed instructions.

6.2.1 Detailed System Wiring Diagram For Single Inverter

Use GM3000 in the system

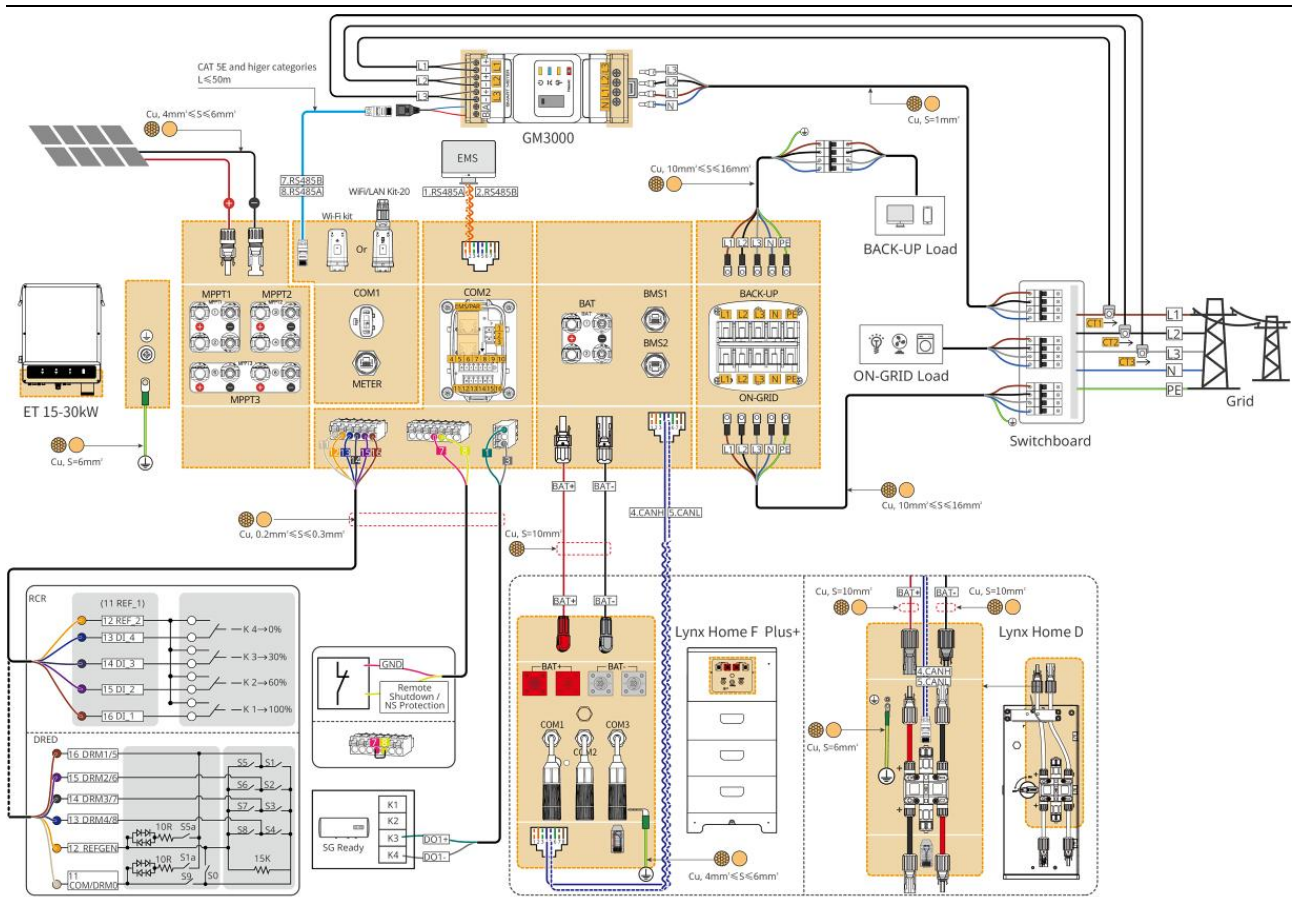

ET3010NET0003

Use GM330 in the system

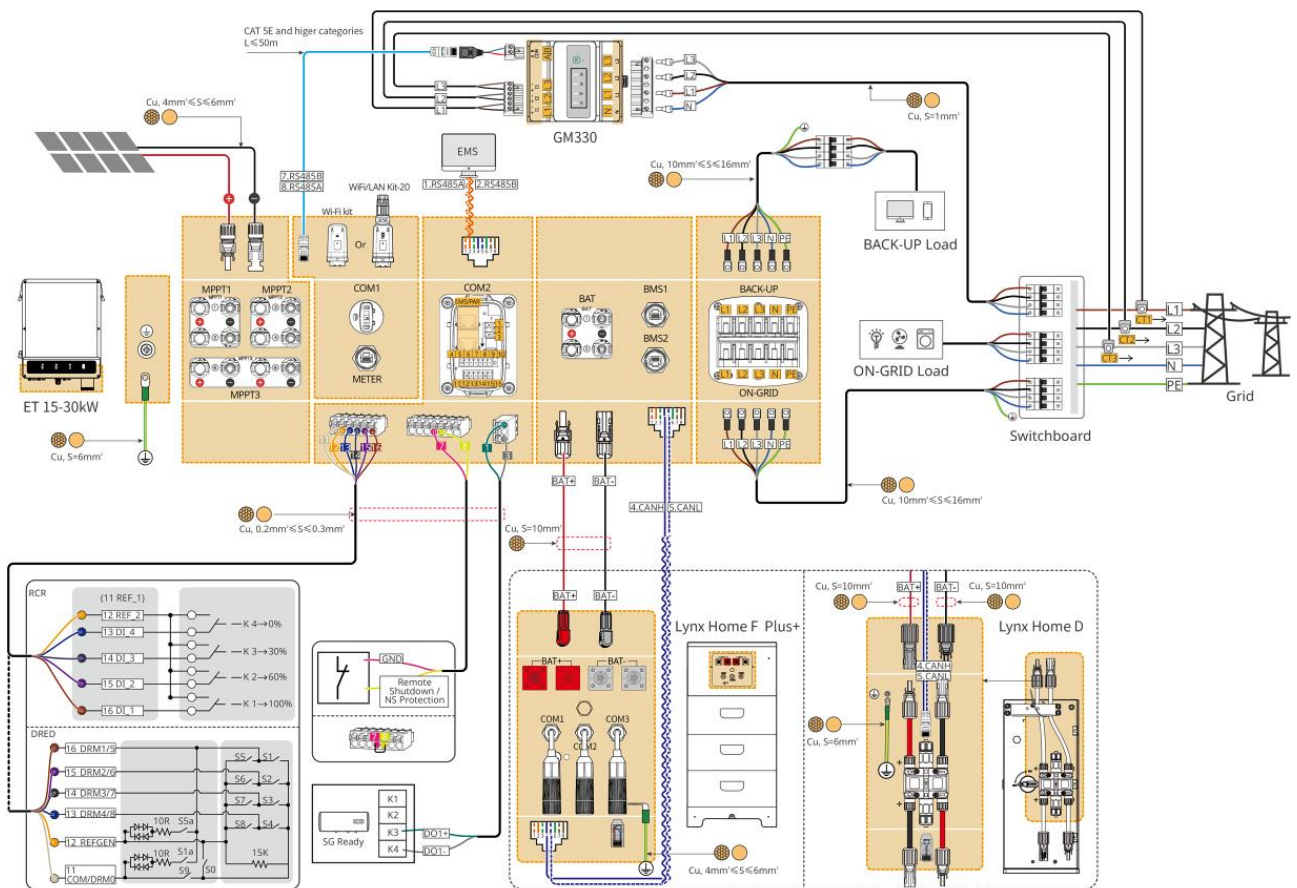

ET3010NET0002

6.2.2 Detailed System Wiring Diagram For Parallel System

- In parallel scenarios, the inverter connecting to Ezlink3000 and smart meter is considered as the master inverter, while all the others are slave inverters. Do not connect any smart dongle to the slave inverters.
- Devices like DRED device, RCR device, remote shutdown device, NS protection device, SG Ready heat pump should be connected to the master inverter.
- The following diagram mainly introduces parallel connections. For other port connections, refer to the single system.

Use GM3000 in the system

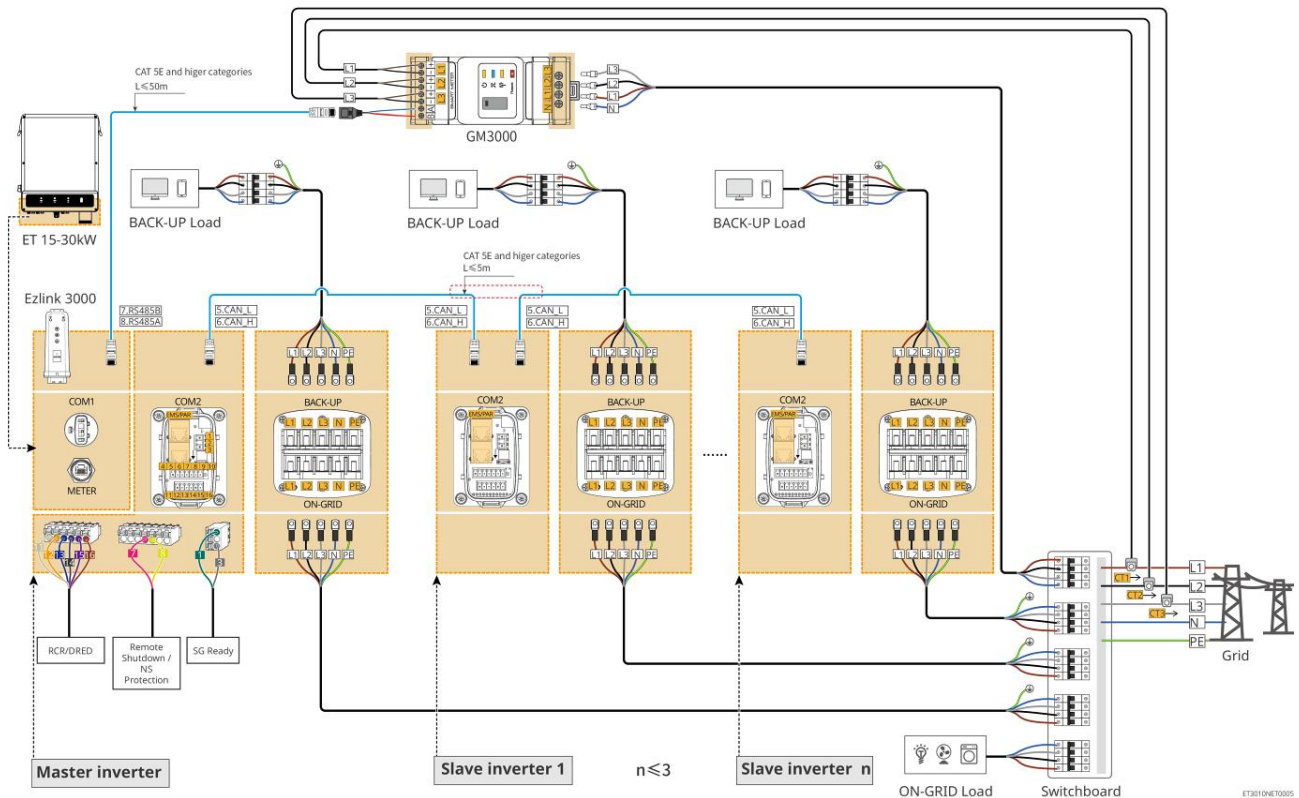

Use GM330 in the system

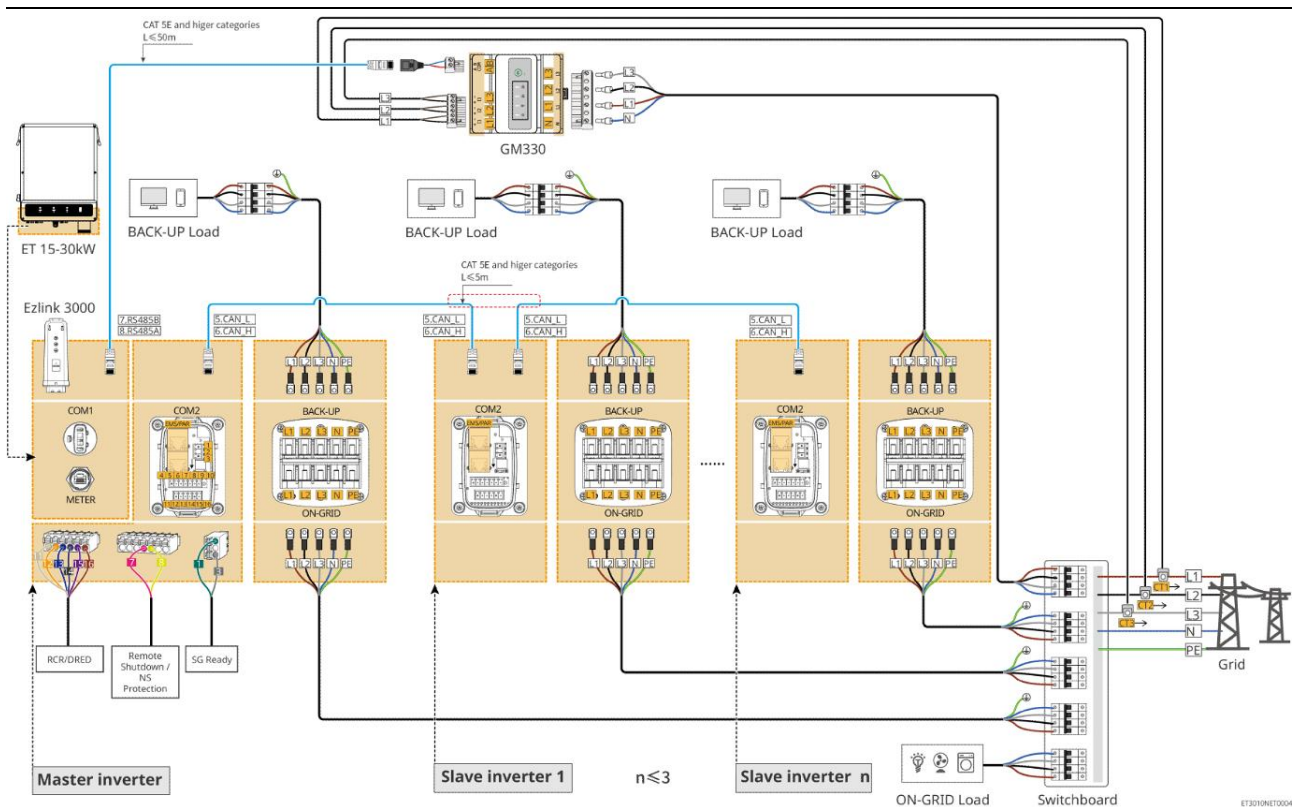

6.3 Preparing Materials

⚠ WARNING

- Do not connect loads between the inverter and the AC switch directly connected to the inverter.
- Install one AC output circuit breaker for each inverter. Multiple inverters cannot share one AC circuit breaker.
- An AC circuit breaker shall be installed on the AC side to make sure that the inverter can safely disconnect the grid when an exception happens. Select the appropriate AC circuit breaker in compliance with local laws and regulations.
- When the inverter is powered on, the BACK-UP AC port is energized. Power off the inverter first if maintenance is required for the loads connected with BACK-UP ports. Otherwise, it may cause electric shock.

6.3.1 Preparing Breakers

No.	Circuit breaker	Recommended specifications	Source
1	ON-GRID breaker BACK-UP breaker	Nominal voltage $\geq 400V$, nominal current: <ul style="list-style-type: none"> ● GW15K-ET: Nominal current $\geq 32A$ ● GW20K-ET: Nominal current $\geq 40A$ ● GW25K-ET: Nominal current $\geq 50A$ ● GW29.9K-ET, GW30K-ET: Nominal current 	Prepared by customers.

		≥63A	
2	Battery breaker	Optional in compliance with local laws and regulations <ul style="list-style-type: none"> ● 2P DC breaker ● Nominal current ≥63A ● Nominal Voltage ≥ 1000V 	Prepared by customers.
3	RCD	Optional in compliance with local laws and regulations <ul style="list-style-type: none"> ● Type A ● ON-GRID RCD: 300mA ● BACK-UP RCD: 30mA 	Prepared by customers.
4	Smart meter breaker	<ul style="list-style-type: none"> ● Nominal Voltage: 380V/ 400V ● Nominal current: 0.5A 	Prepared by customers.

6.3.2 Preparing Cables

No.	Cable	Recommended specifications	Source
1	Inverter PE cable	<ul style="list-style-type: none"> ● Single-core outdoor copper cable ● Conductor cross-sectional area: S=6mm² 	Prepared by customers.
2	Battery PE cable	<ul style="list-style-type: none"> ● Single-core outdoor copper cable ● Conductor cross-sectional area: 6mm² 	Prepared by customers.
3	PV DC cable	<ul style="list-style-type: none"> ● Commonly used outdoor photovoltaic cable ● Conductor cross-sectional area: 4mm²-6mm² ● Outer diameter: 4mm-5mm 	Prepared by customers.
4	Battery DC cable	<ul style="list-style-type: none"> ● Single-core outdoor copper cable ● Conductor cross-sectional area: 10mm² ● Outer diameter: 6.5mm-8.5mm 	Prepared by customers or buy from GoodWe.
5	AC cable	<ul style="list-style-type: none"> ● Multi-core outdoor copper cable ● Conductor cross-sectional area: 10mm²- 16mm² ● Outer diameter: 21mm-26mm 	Prepared by customers.
6	Smart meter power cable	Outdoor copper cable Conductor cross-sectional area: 1mm ²	Prepared by customers.
7	BMS communication cable	Recommended specifications if needed: CAT 5E or higher categories standard net cable	Included in the package of the

		with RJ45 connector.	inverter.
8	Smart meter RS485 communication cable	Standard network cable: CAT 5E or higher categories net cable with RJ45 connector.	RJ45-2PIN adapter and standard net cable: included in the package of the inverter.
9	Communication cable for battery parallel connection	CAT 5E or higher categories standard net cable with RJ45 connector.	Prepared by customers.
10	DO communication cable for load control	<ul style="list-style-type: none"> ● Shielded cable that meet local requirements ● Conductor cross-sectional area: 0.2mm²-0.3mm² ● Outer diameter: 5mm-8mm 	Prepared by customers.
11	Remote shutdown communication cable		Prepared by customers.
12	RCR/DRED communication cable		Prepared by customers.
13	Communication cable for parallel connected inverters	CAT 5E or higher categories standard net cable with RJ45 connector.	Prepared by customers.
14	EMS communication cable	CAT 5E or higher categories standard net cable with RJ45 connector.	Prepared by customers.
15	12V power supply	<ul style="list-style-type: none"> ● Outdoor copper cable ● Conductor cross-sectional area: 0.2mm²-0.3mm² ● Outer diameter: 5mm-8mm 	Prepared by customers.

6.4 Connecting the PE cable

WARNING

- Connect the PE cable first when installing the equipment. Disconnect the PE cable last when removing the equipment.
- The PE cable connected to the enclosure of the inverter cannot replace the PE cable connected to the AC output port. Make sure that both of the two PE cables are securely connected.
- Make sure that all the grounding points on the enclosures are equipotentially connected when there are multiple inverters.
- To improve the corrosion resistance of the terminal, you are recommended to apply silica gel or paint on the ground terminal after installing the PE cable.

Inverter

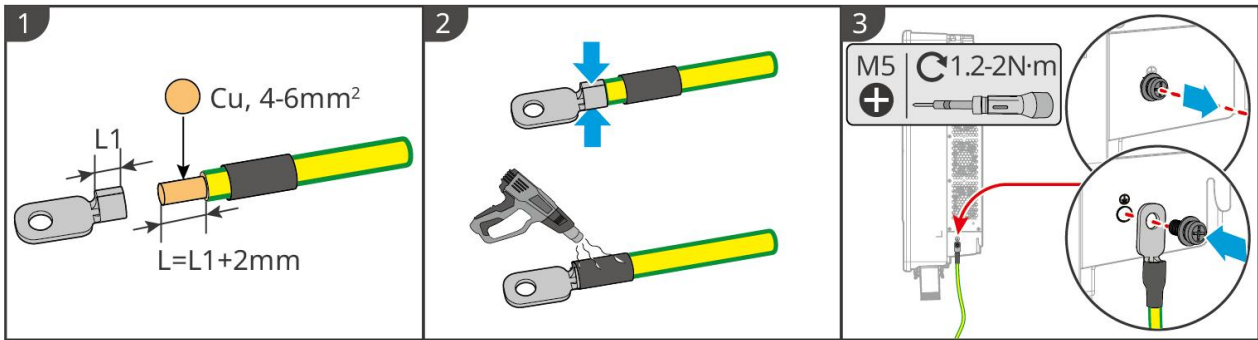

ET3010ELC0001

Battery System

NOTICE

The drawing force of the cable after crimping should be at least 400N.

Lynx Home F series

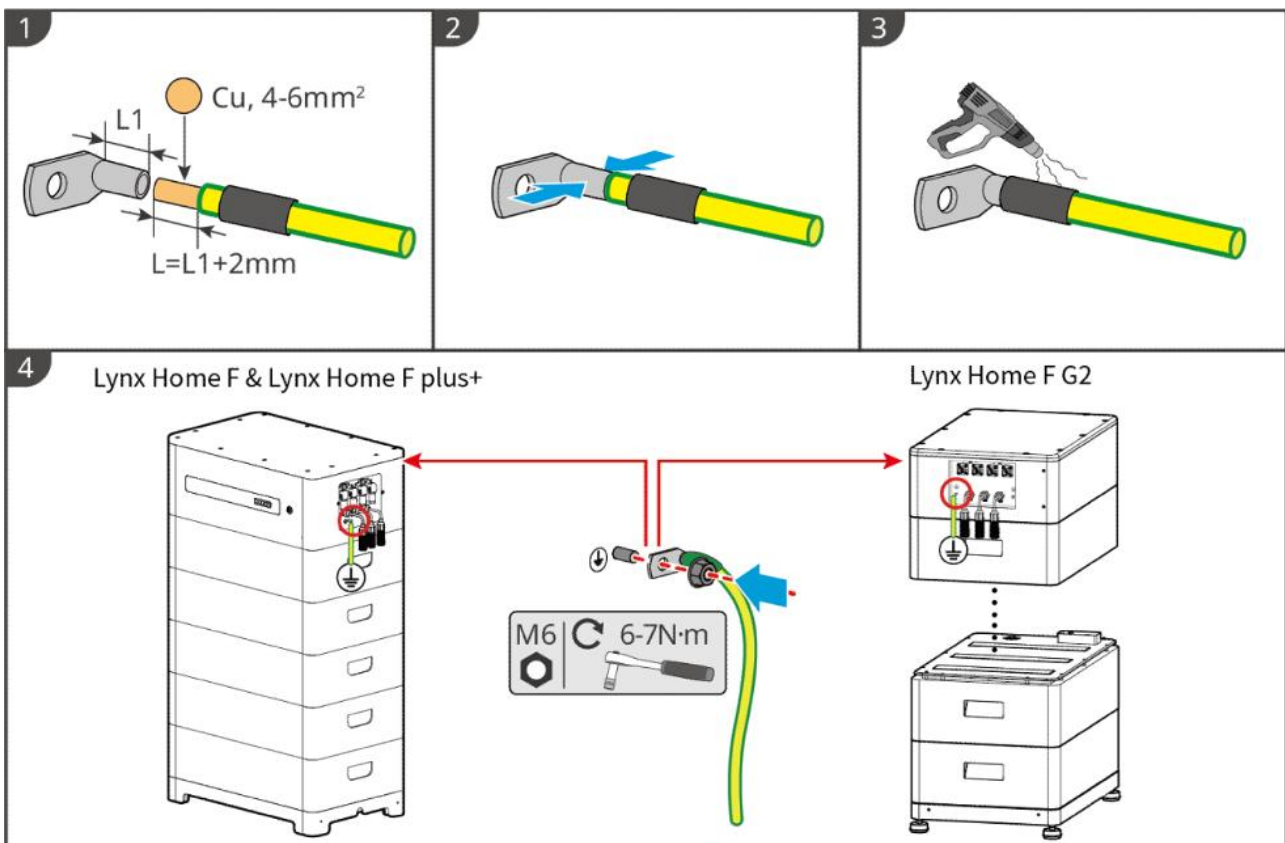

LXF10ELC0001

Lynx Home D

Connect the grounding cable to any grounding point of the battery system.

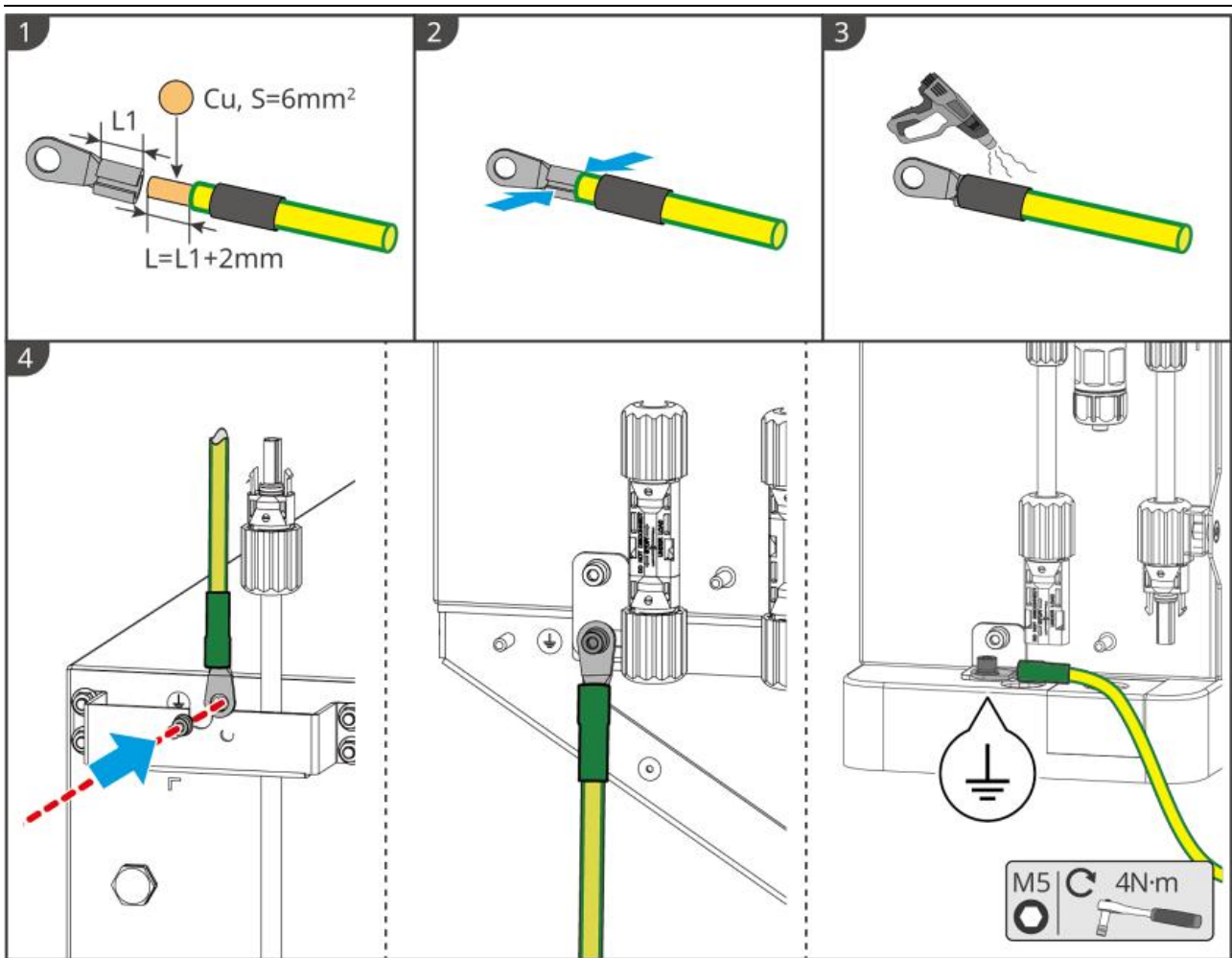

LXD20ELC0001

6.5 Connecting the PV Cable

DANGER

- Do not connect one PV string to more than one inverter at the same time. Otherwise, it may cause damage to the inverter.
- High voltage exists when the PV string is exposed to the sunlight, pay attention during electrical connections.
- Confirm the following information before connecting the PV string to the inverter. Otherwise, the inverter may be damaged permanently or even cause fire and cause personal and property losses.
 1. Make sure that the max short circuit current and the max input voltage per MPPT are within the permissible range.
 2. Make sure that the positive pole of the PV string connects to the PV+ of the inverter. And the negative pole of the PV string connects to the PV- of the inverter.

WARNING

- The PV strings cannot be grounded. Ensure the minimum insulation resistance of the PV string to the ground meets the minimum insulation resistance requirements before connecting the

PV string to the inverter (R=maximum input voltage/ 30mA).

- Ensure the DC cables are connected tightly, securely and correctly.
- Measure the DC cable using the multimeter to avoid reverse polarity connection. Also, the voltage should be within the permissible range.

NOTICE

The two input strings per MPPT should be of the same type, the same number of modules, the same tilt and angle to ensure the best efficiency.

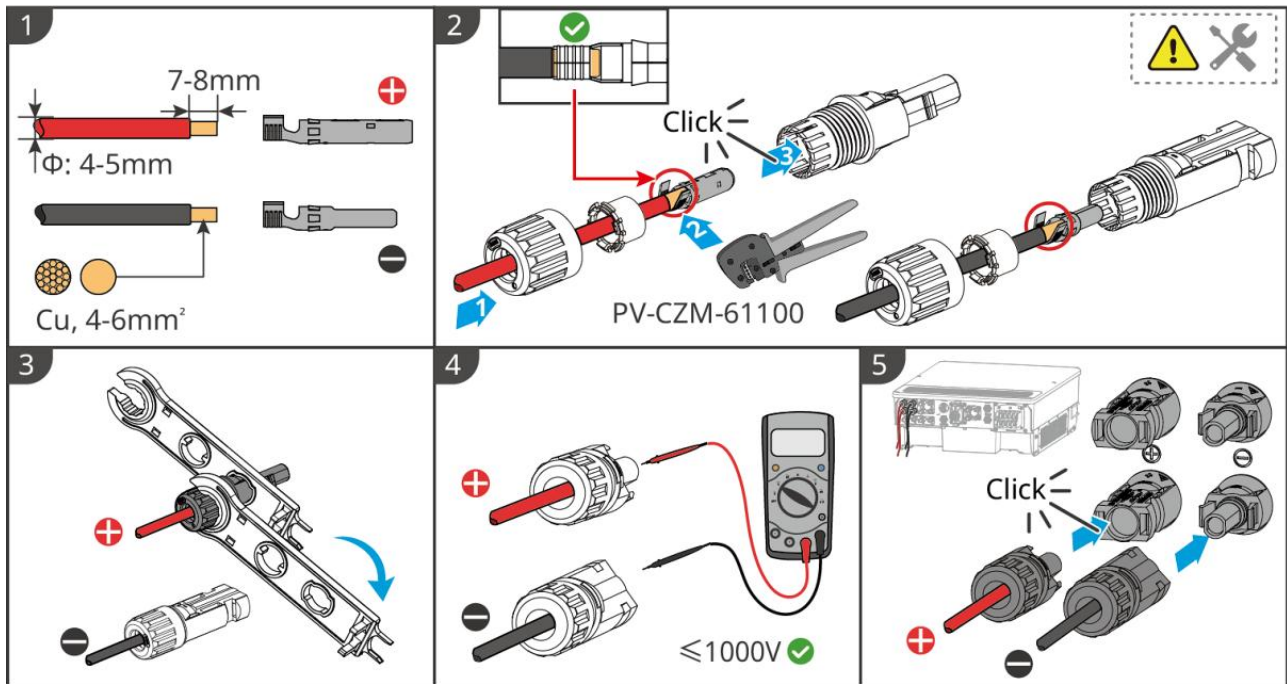

ET3010ELC0002

6.6 Connecting the Battery Cable

DANGER

- Do not connect one battery pack to more than one inverter at the same time. Otherwise, it may cause damage to the inverter.
- It is forbidden to connect loads between the inverter and batteries.
- When connecting battery cables, use insulated tools to prevent accidental electric shock or short circuit to the batteries.
- Ensure that the open circuit voltage of the battery is within the permissible range of the inverter.
- Install a DC breaker between the inverter and the battery in compliance with local laws and regulations.

There are two battery input port in GW25K-ET, GW29.9K-ET and GW30K-ET, follow the rules below when connecting the battery system to the inverter.

Quantity of battery system	Battery system connected to BAT1	Battery system connected to BAT2
1	1	0

2	1	1
3	2	1
4	2	2
.....
15	8	7
16	8	8

Battery system wiring diagram

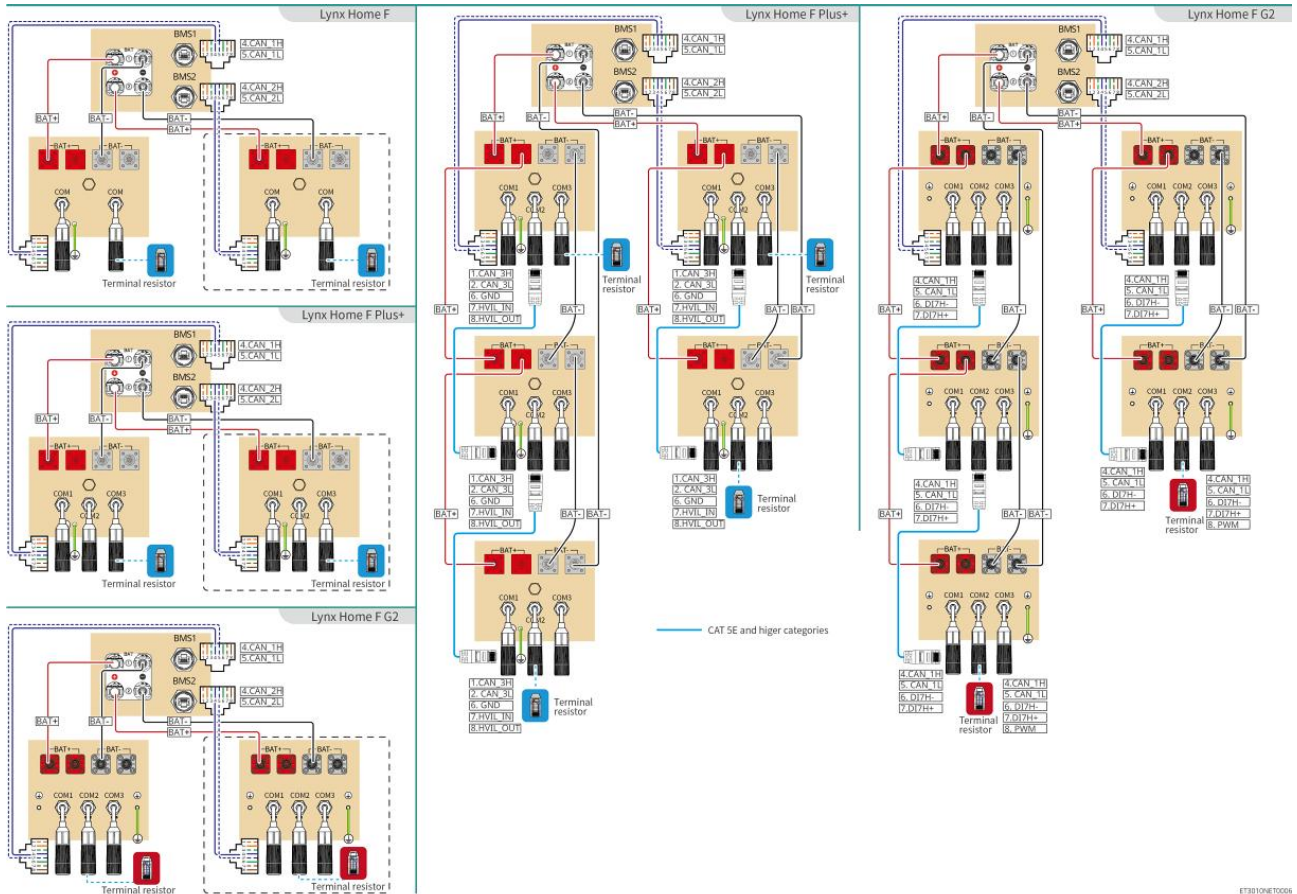

ETB310NE.T0005

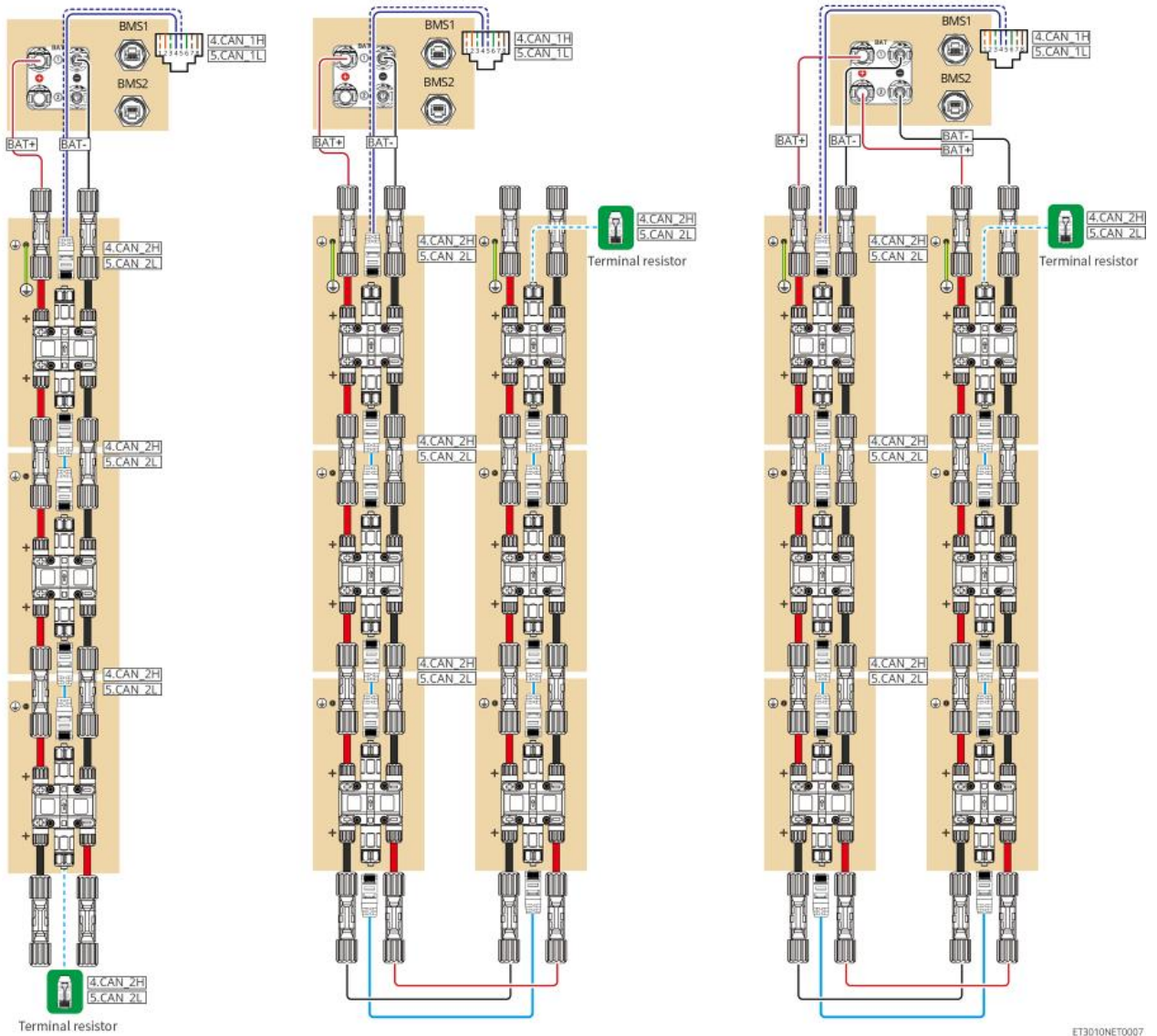

ET3010NET0007

BMS communication between the inverter and the Lynx Home F Series battery:

Inverter port	Connected to the battery port	Port definition	Description
BMS1/BMS2	COM1/COM2/COM	4: CAN_H 5: CAN_L	<ul style="list-style-type: none"> The inverter communicates with the battery through CAN. Connect the BMS1 port of the inverter to the COM1 port of the battery. When the nominal dis-/charge current of the battery is higher than 50A, the battery is recommended to be connected to BAT1 and BAT2 ports of the inverter. The BMS communication cable should be connected to the BMS1 port of the inverter and the COM1 port of the battery.

Definition of the battery communication port (Lynx Home F):

PIN	COM	Description
4	CAN_H	Connects to the inverter BMS communication port to communication with the inverter; or terminal resistor.
5	CAN_L	
1, 2, 3, 6, 7, 8	-	-

Communication between the parallel connected Lynx Home F Plus+ batteries:

PIN	COM1	COM2	COM3	Description
1	CAN_3H	CAN_3H	CAN_3H	BMS communication for battery system parallel connections
2	CAN_3L	CAN_3L	CAN_3L	
3	-	-	-	Reserved
4	CAN_2H	-	-	<ul style="list-style-type: none"> ● COM1: connects to the inverter BMS communication port to communication with the inverter ● COM2, COM3: reserved
5	CAN_2L	-	-	
6	GND	GND	GND	PIN for grounding.
7	HVIL_IN	HVIL_IN	-	<ul style="list-style-type: none"> ● COM1, COM2: interlock function ● COM3: reserved
8	HVIL_OUT	HVIL_OUT	-	

Communication between the parallel connected Lynx Home F G2 batteries:

PIN	COM1	COM2	COM3	Description
1	RS485A	RS485A	Reserved	Connects the external communication device through RS485
2	RS485B	RS485B		
3	-	-		Reserved
4	CAN_1H	CAN_1H		Connects the inverter communication port or battery parallel communication port
5	CAN_1L	CAN_1L		
6	DI7H-	DI7H-		Detects the cluster signal of the battery system.
7	DI7H+	DI7H+		
8	-	PWM		Sends paralleled PWM signals.

BMS communication between the inverter and the Lynx Home D battery

Inverter	Connected to the battery	Port	Description
----------	--------------------------	------	-------------

port	port	definition	
BMS1	COM	4: CANH1 5: CANL1	<ul style="list-style-type: none"> ● The inverter communicates with the battery through CAN. ● Connects the BMS1 port of the inverter to the communication port of the battery.

Communication between the parallel connected Lynx Home D batteries:

PIN	Battery port	Description
1	RS485A	Reserved
2	RS485B	
4	CAN_H	For communication between the inverter and the battery or the parallel connected batteries.
5	CAN_L	
3/6/7/8	-	-

6.6.1 Connecting the Power Cable Between the Inverter and Battery

 **WARNING**

- Measure the DC cable using the multimeter to avoid reverse polarity connection. Also, the voltage should be within the permissible range.
- Connect the battery cables to the corresponding terminals such BAT+, BAT- and grounding ports correctly. Otherwise it will cause damage to the inverter.
- Ensure that the whole cable cores are inserted into the terminal holes. No part of the cable core can be exposed.
- Ensure that the cables are connected securely. Otherwise it will cause damage to the inverter due to overheat during its operation.
- Do not connect one battery pack to more than one inverter at the same time. Otherwise, it may cause damage to the inverter.

Inverter + Lynx Home F Series battery

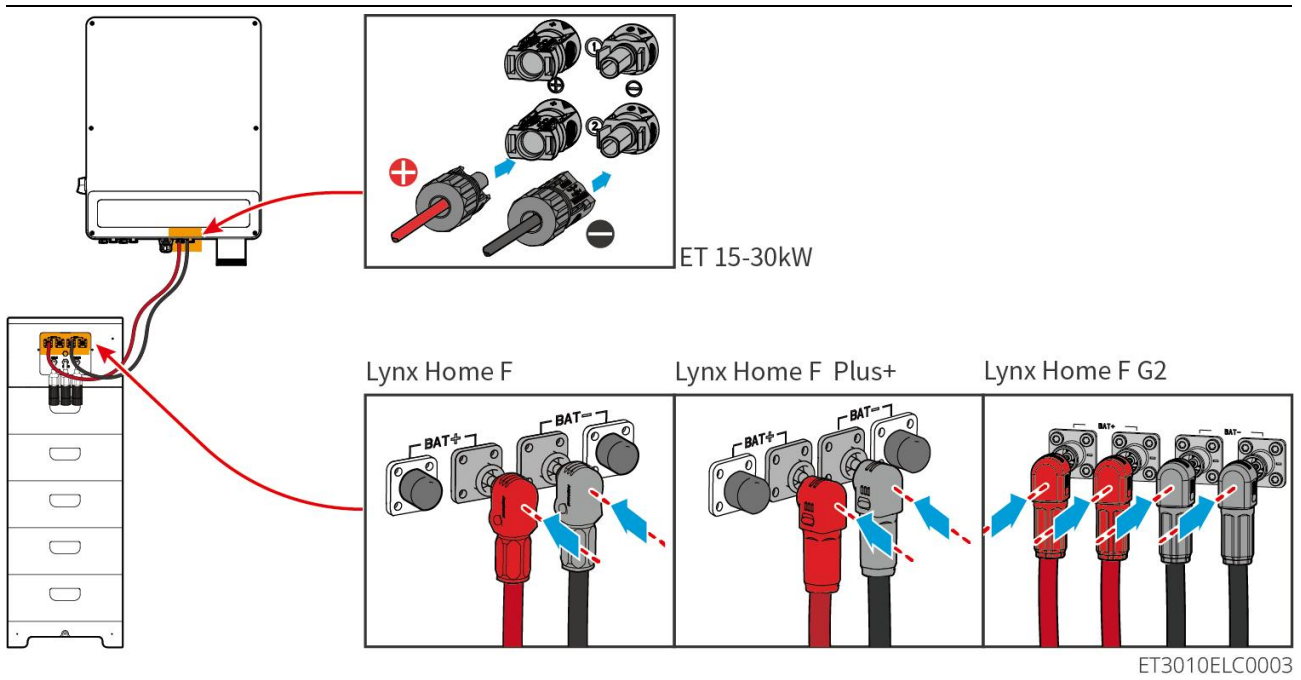

Inverter + Lynx Home D batteries

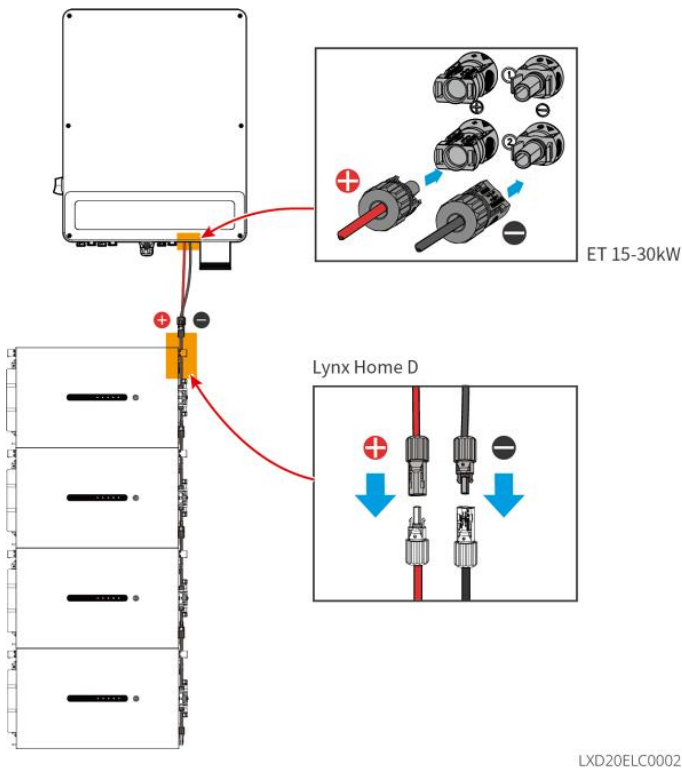

Make the inverter power cable

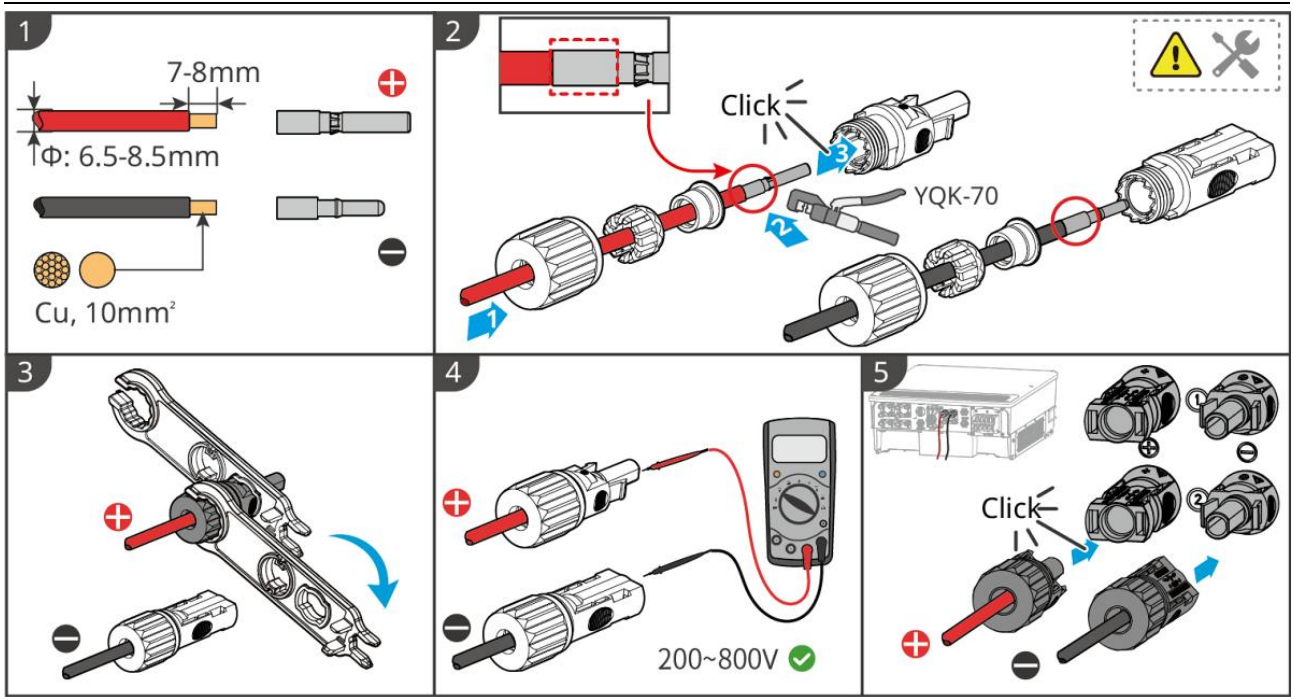

Make the battery power cable (Lynx Home F)

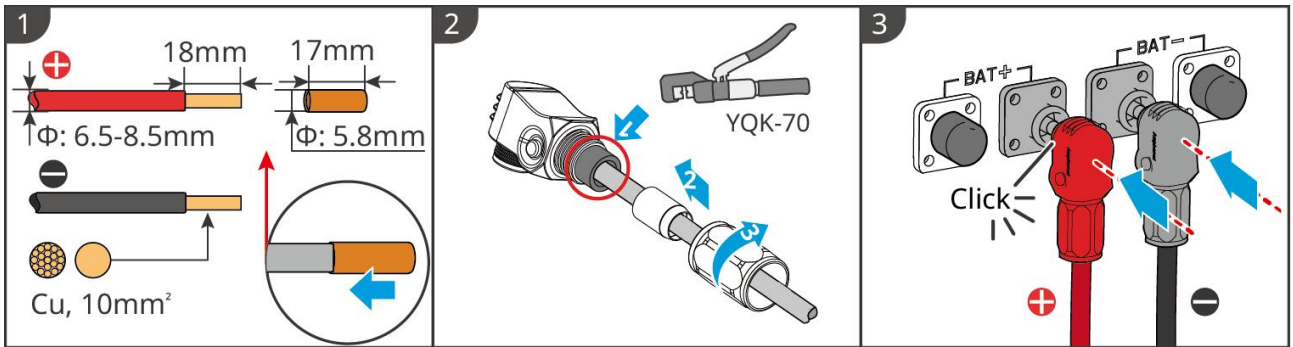

Make the battery power cable (Lynx Home F Plus+)

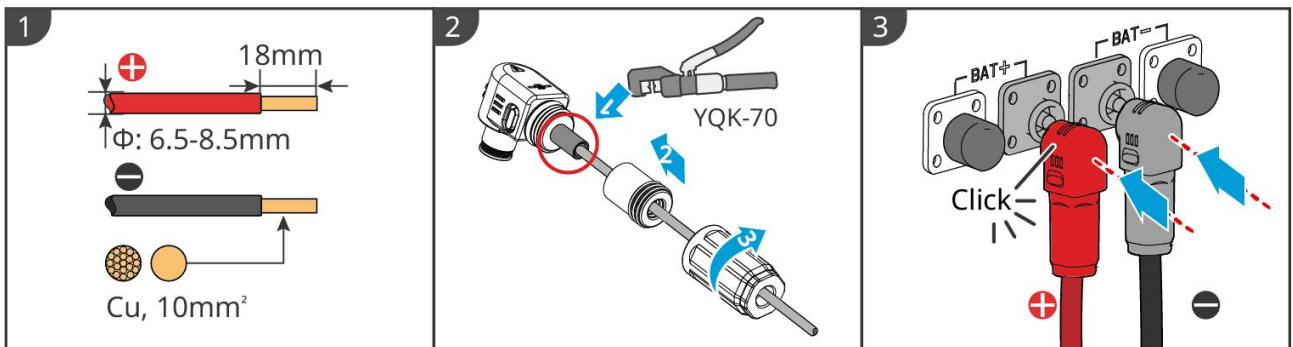

Make the battery power cable (Lynx Home F G2)

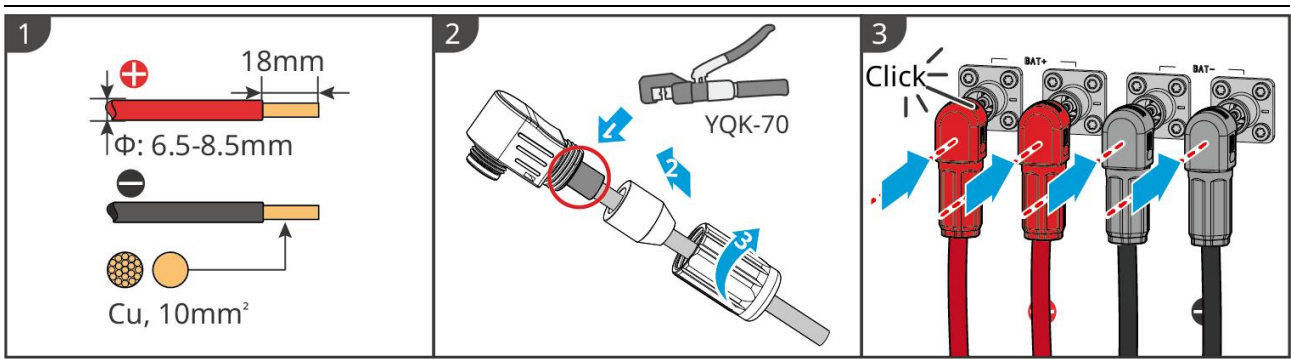

LXF20ELC008

Make the battery power cable (Lynx Home D)

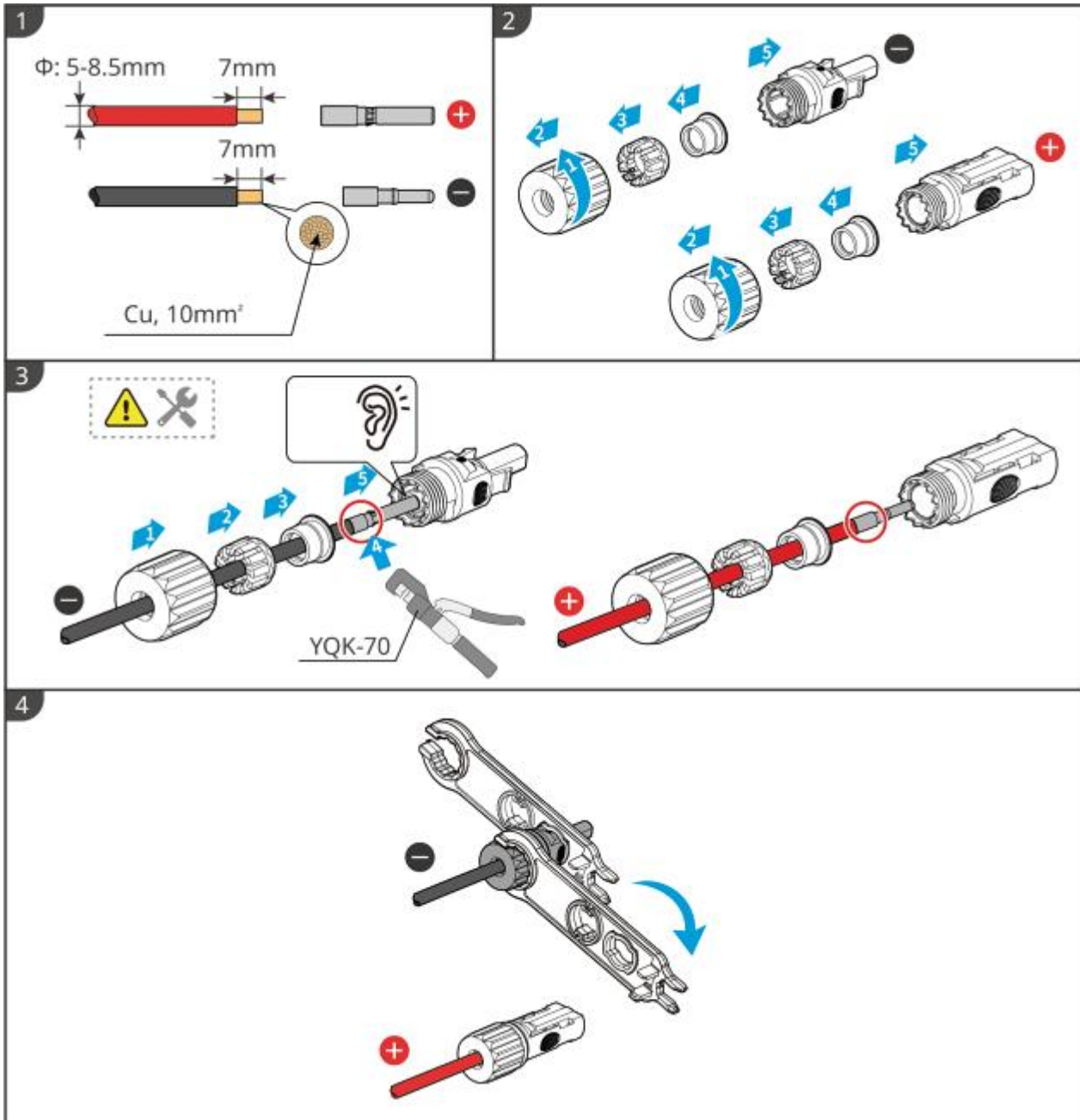

LXD20ELC003

6.6. 2 Connecting the Communication Cable Between the Inverter and Battery

NOTICE

The BMS cable is included in the package of the inverter, the included BMS communication cable is recommended. If more communication cables are needed, prepare shielded network cables and RJ connectors by yourself to make the cable. Only crimp PIN4 and PIN5 of the connector when making the cable, otherwise the communication may fail.

Inverter + Lynx Home F Series battery

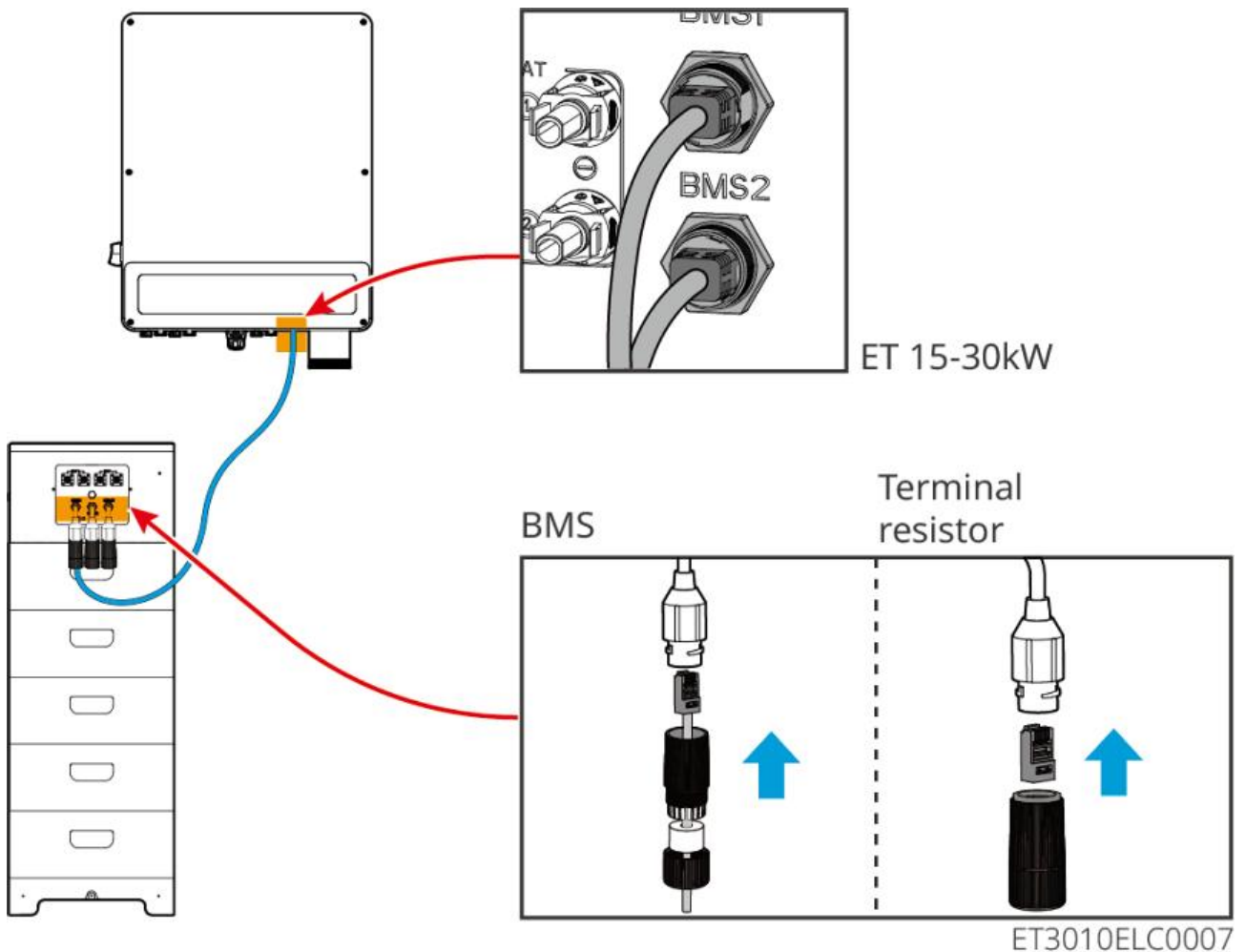

Inverter + Lynx Home D batteries

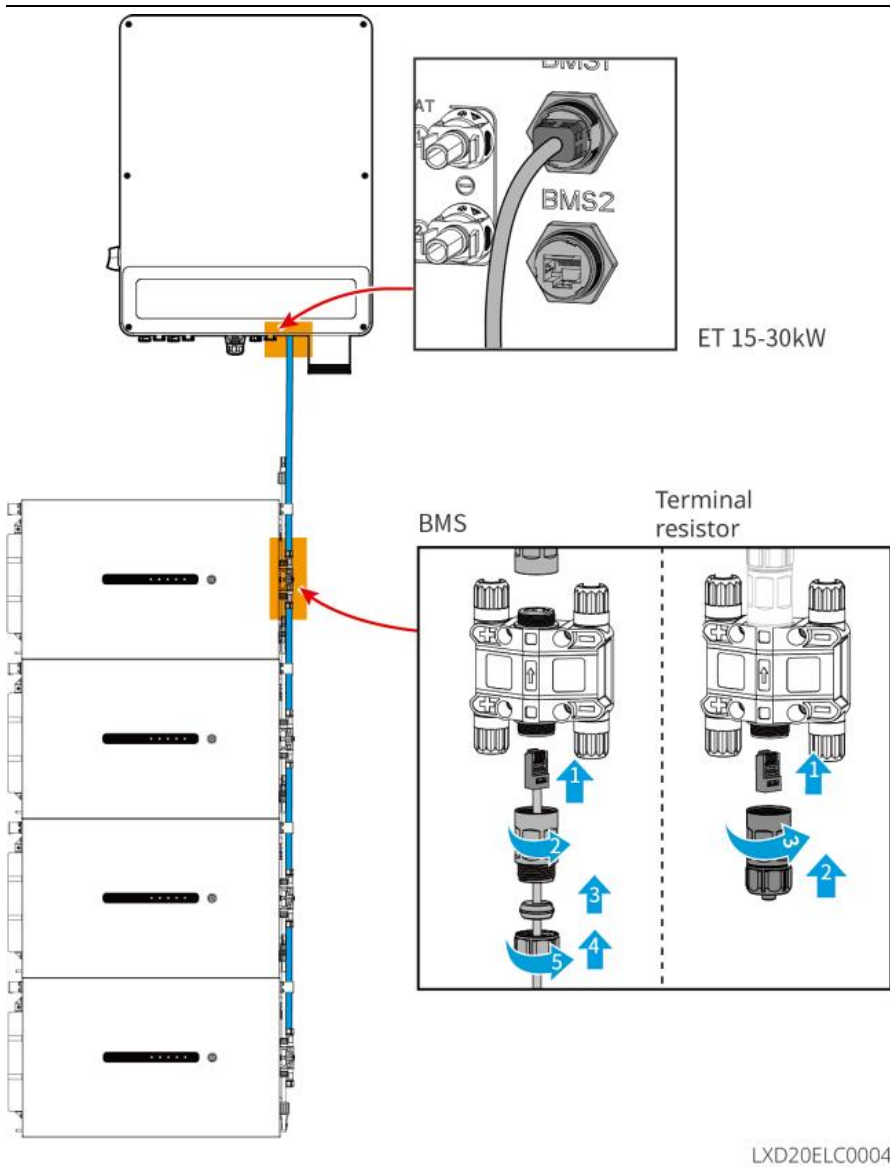

LXD20ELC0004

6.6.3 Connecting the Power Cable and Communication Cable Between Lynx Home D batteries

6.6.3.1 Power cable

Crimping the Power cable

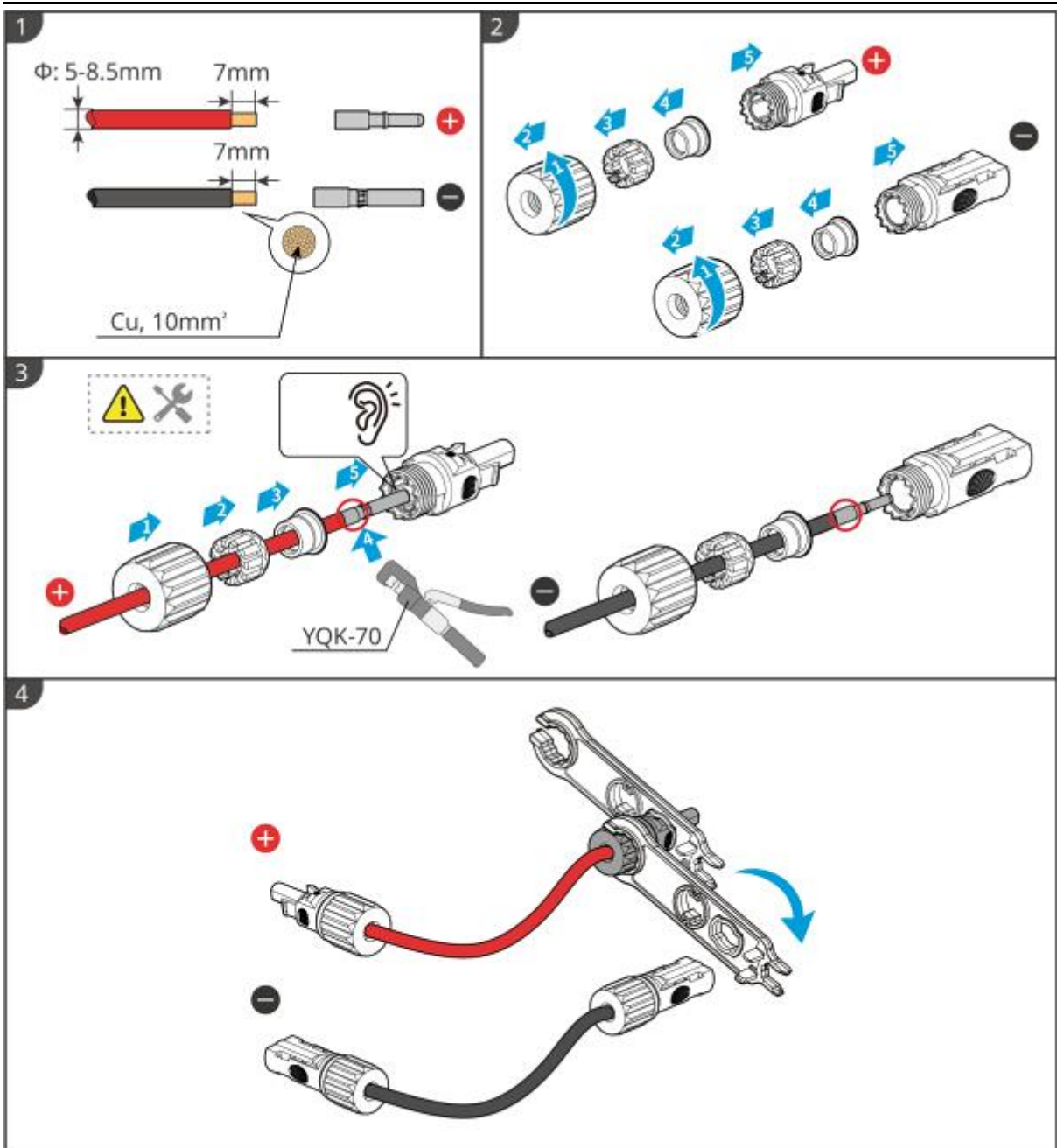

Connecting the Power cable

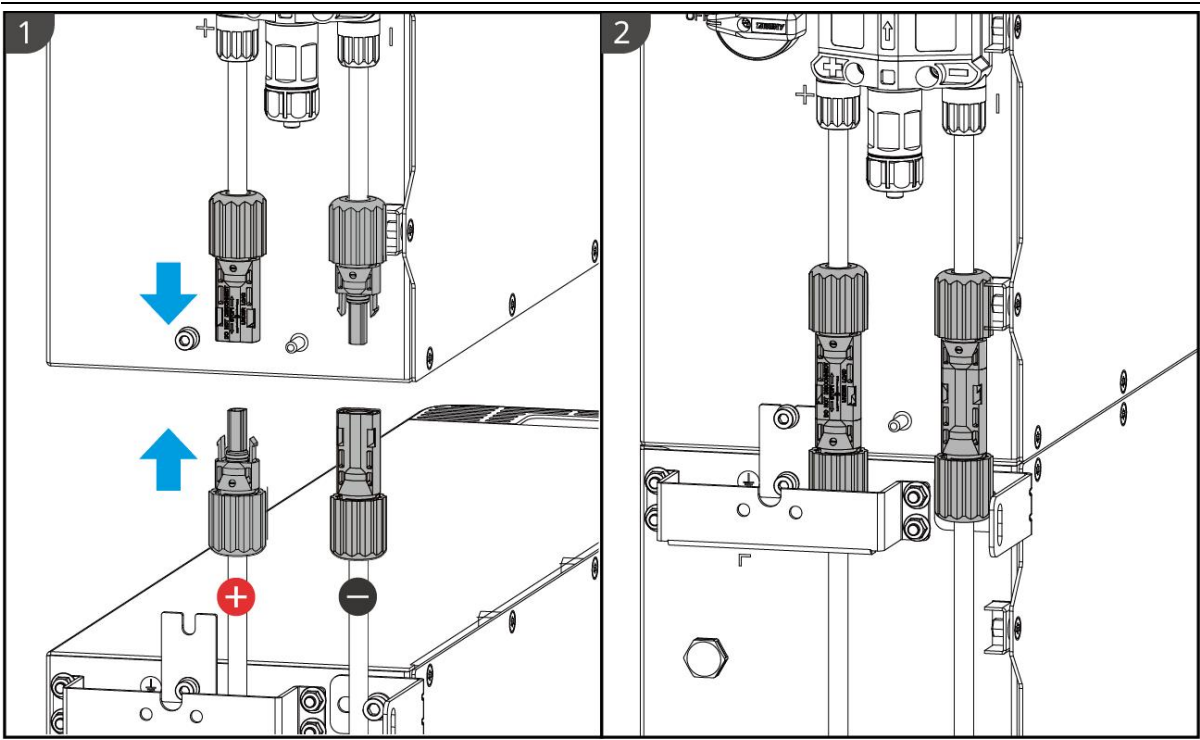

LXD20ELC0006

Use the package included tool and follow the steps below to remove the power connector.

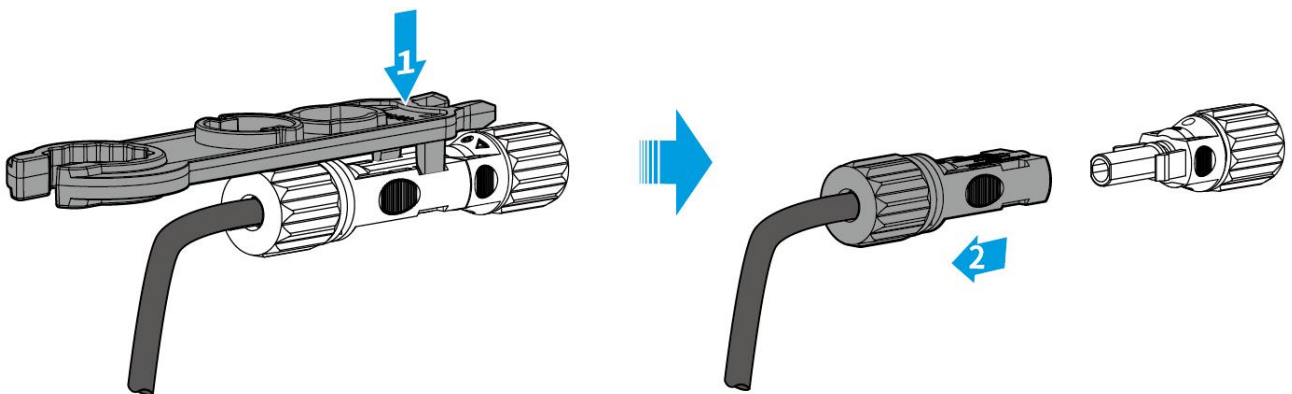

LXD20ELC0007

6.6.3.2 Communication Cable and Terminal Resistor

Use the communication cable and terminal resistor included in the package.

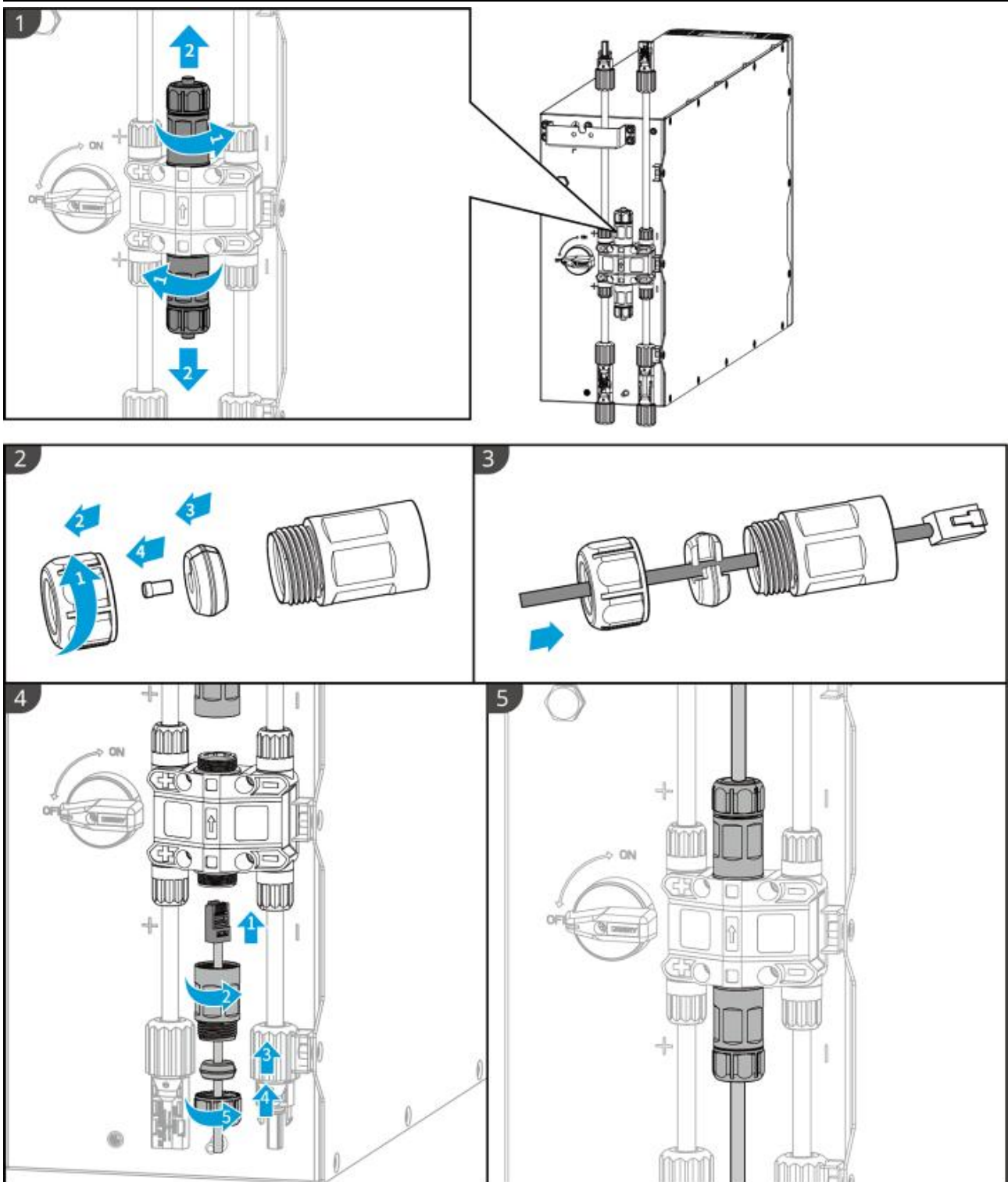

LXD20ELC0008

⚠ WARNING

- Do not forget to install the terminal resistor, otherwise the battery system cannot work properly.
- Do not remove the waterproof plug during installation.

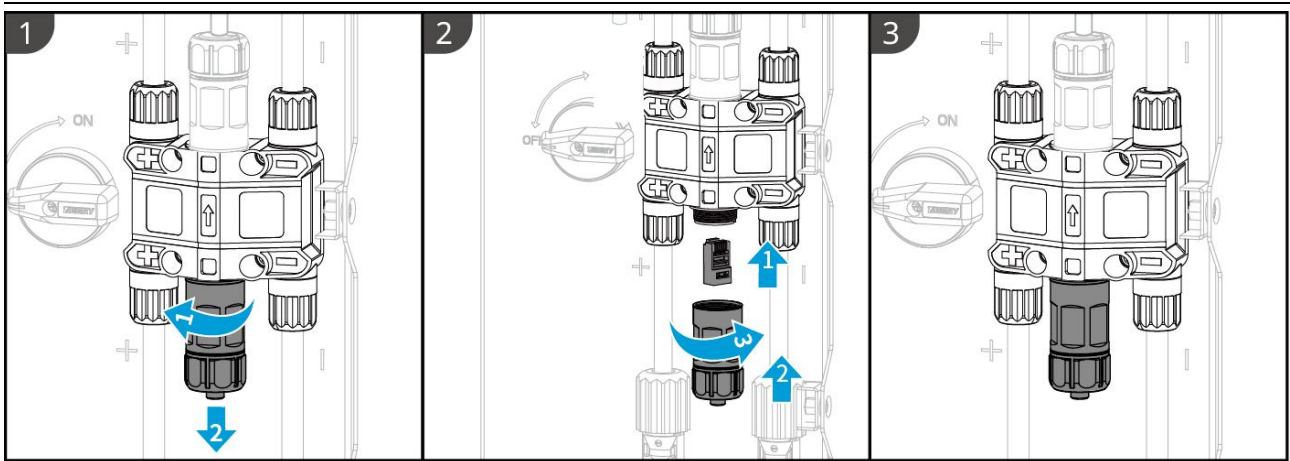

LXD20ELC0009

6.6.3.3 Installing the Protective Cover

NOTICE

Remove the release paper on the back of the protective cover before installing the front protective cover of the rack.

Step 1 (Optional) For ground installation only. If no cable pass through the base, install a hole plug here.

Step 2 Install the side cover of the battery.

Step 3 (Optional) For wall mount installation only. Install the cover of the wall mounting rack.

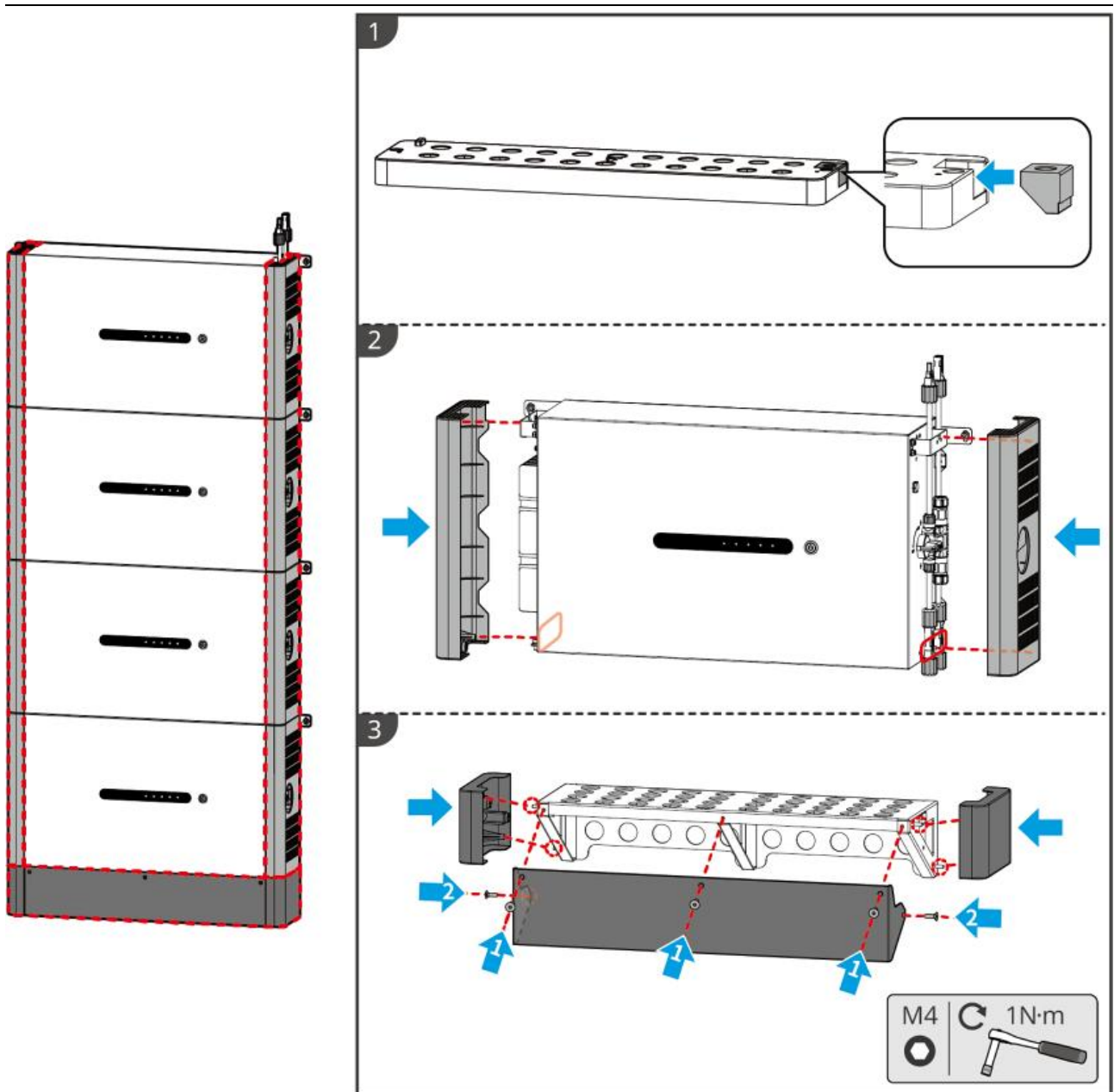

LXD20INT0004

6.7 Connecting the AC Cable

WARNING

- The residual current monitoring unit (RCMU) is integrated into the inverter to avoid the residual current exceeds the limit. The inverter will disconnect the utility grid quickly once it found the residual current exceeds the limit.
- Install one AC output circuit breaker for each inverter. Multiple inverters cannot share one AC circuit breaker.
- An AC circuit breaker shall be installed on the AC side to make sure that the inverter can safely disconnect the grid when an exception happens. Select the appropriate AC circuit breaker in compliance with local laws and regulations.
- When the inverter is powered on, the BACK-UP AC port is energized. Power off the inverter first if maintenance is required for the loads connected with BACK-UP ports. Otherwise, it may cause electric shock.

- Connect the AC cables to the corresponding terminals such as “L1”, “L2”, “L3”, “N”, and “PE” correctly. Otherwise it will cause damage to the inverter.
- Ensure that the whole cable cores are inserted into the terminal holes. No part of the cable core can be exposed.
- Ensure that the insulation board is inserted into the AC terminal tightly.
- Ensure that the cables are connected securely. Otherwise it will cause damage to the inverter due to overheat during its operation.
- The type A RCD can be connected to the inverter for protection according to the local laws and regulations. Recommended specifications: ON-GRID RCD: 300mA; BACK-UP RCD: 30mA.

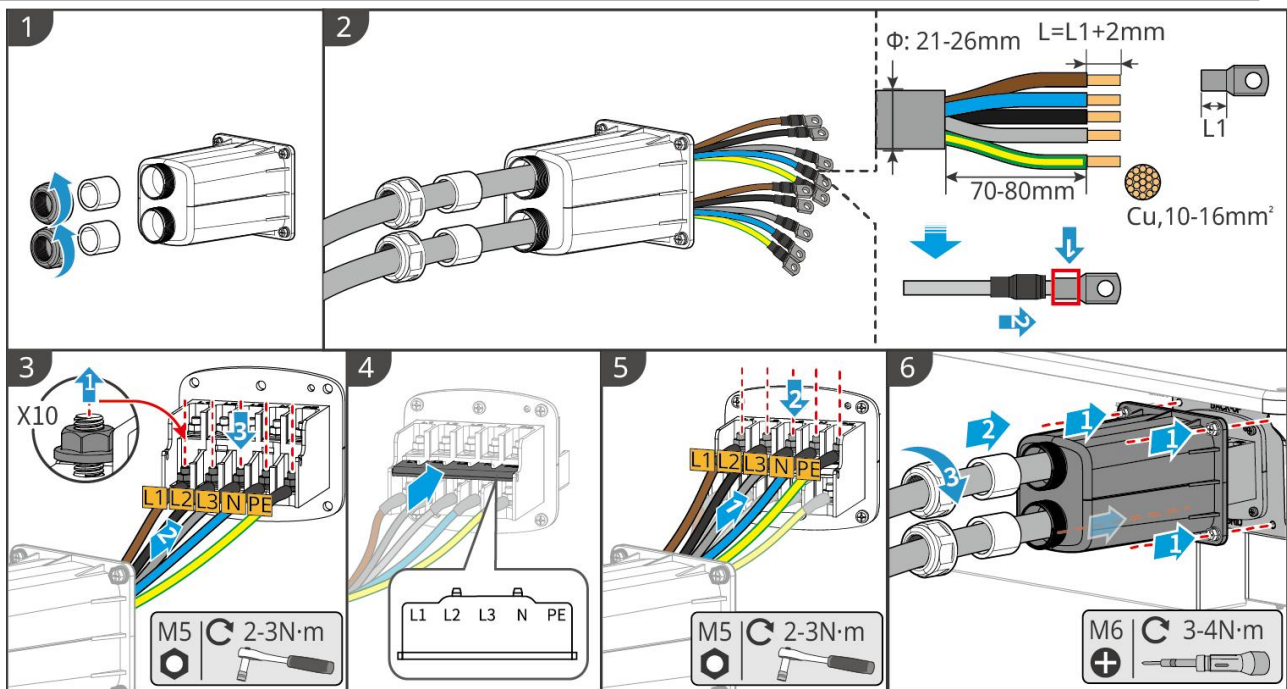

ET3010ELC0006

6.8 Connecting the Meter cable

NOTICE

- The smart meter included in the package is intended for a single inverter. Do not connect one smart meter to multiple inverters. Contact the manufacturer for additional smart meters if multiple inverters are connected.
- Ensure that the CT is connected in the correct direction and phase sequences, otherwise the monitoring data will be incorrect.
- Ensure the cables are connected tightly, securely and correctly. Inappropriate wiring may cause poor contacts and damage the equipment.
- In areas at risk of lightning, if the meter cable exceeds 10m and the cables are not wired with grounded metal conduits, you are recommended to use an external lightning protection device.

Wiring of GM3000

NOTICE

- Outer diameter of the AC cable should be smaller than the hole diameter of the CT, so that the AC cable can be routed through the CT.
- To ensure accurate current detection, the CT cable is recommended to be shorter than

30m.

- Do not use network cable as the CT cable, otherwise the smart meter may be damaged due to high current.
- The CTs vary slightly in dimensions and appearance depending on the model, but they are installed and connected in the same way.

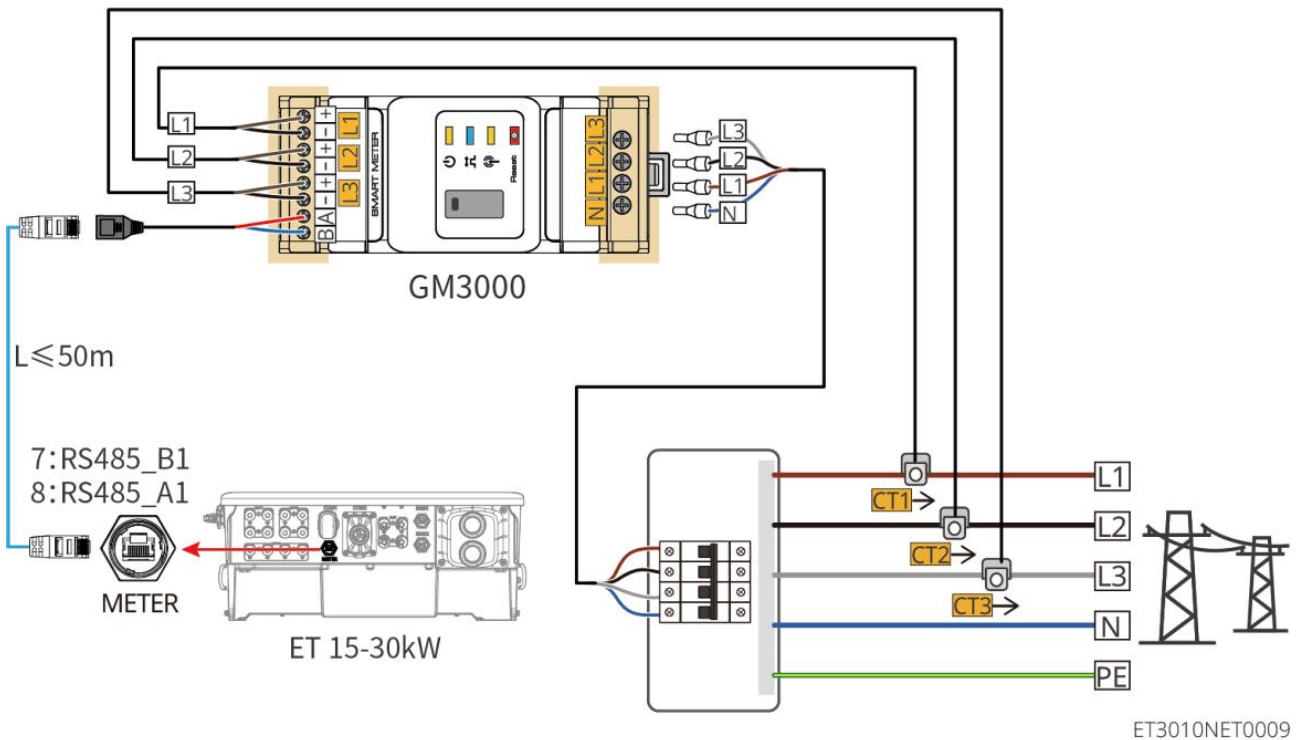

Connection steps

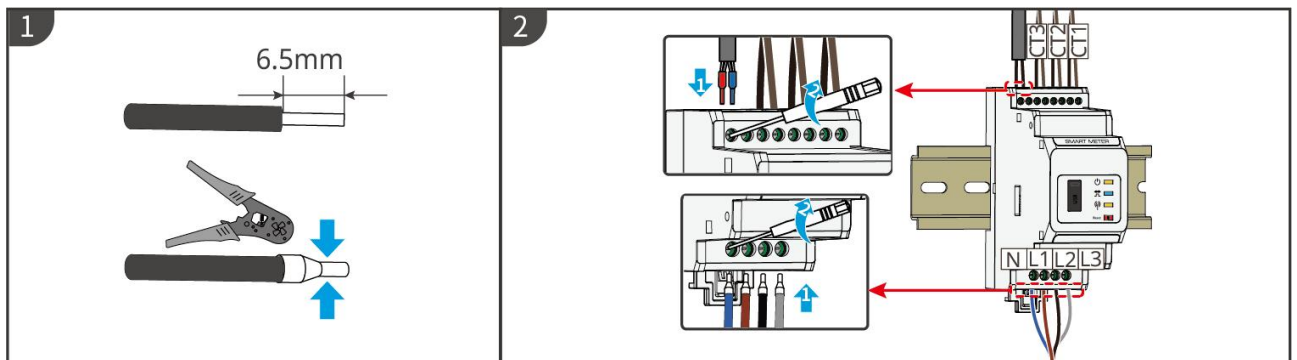

Wiring of GM330

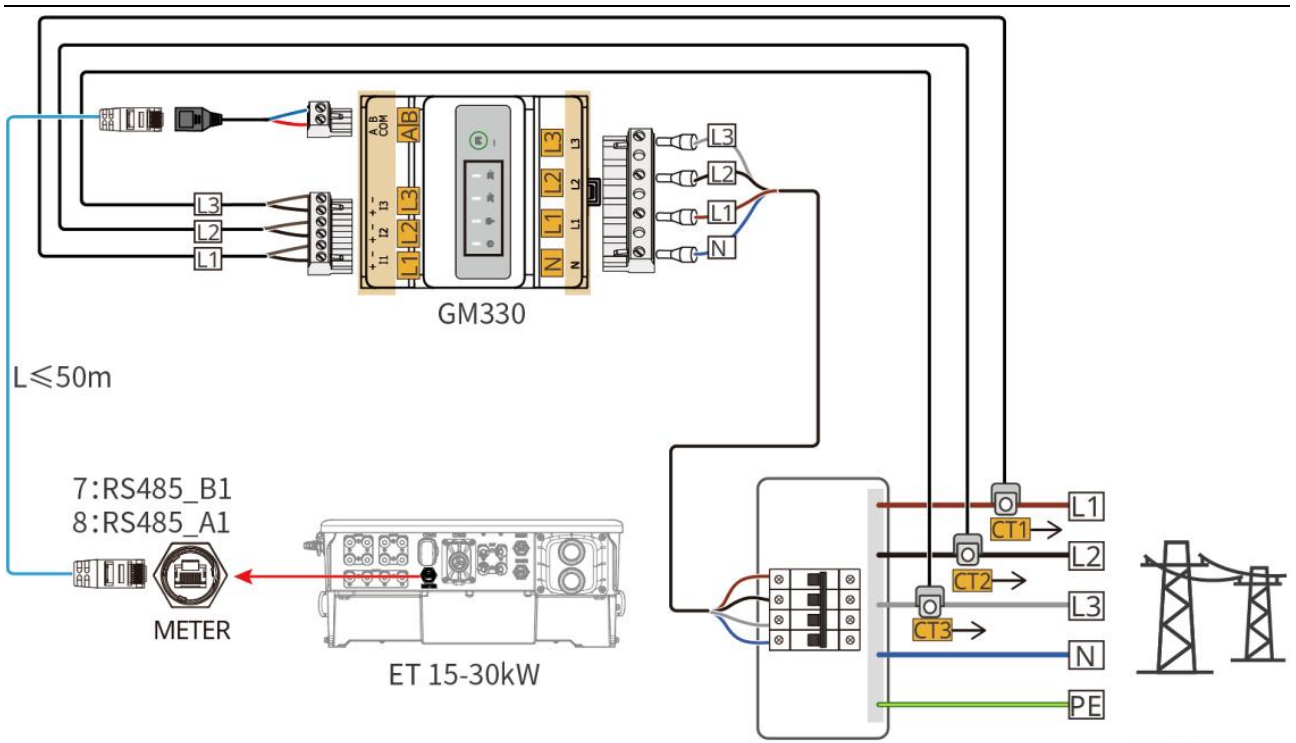

Connection steps

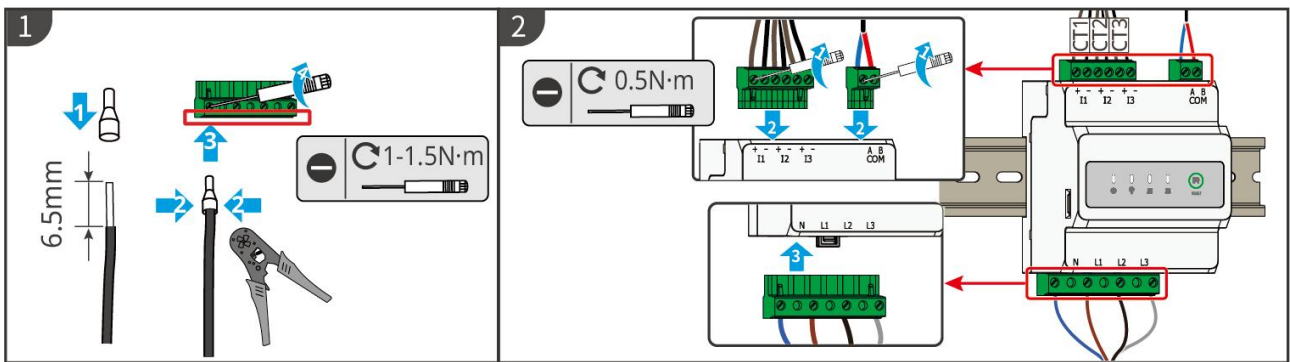

Installing the CT (Type I)

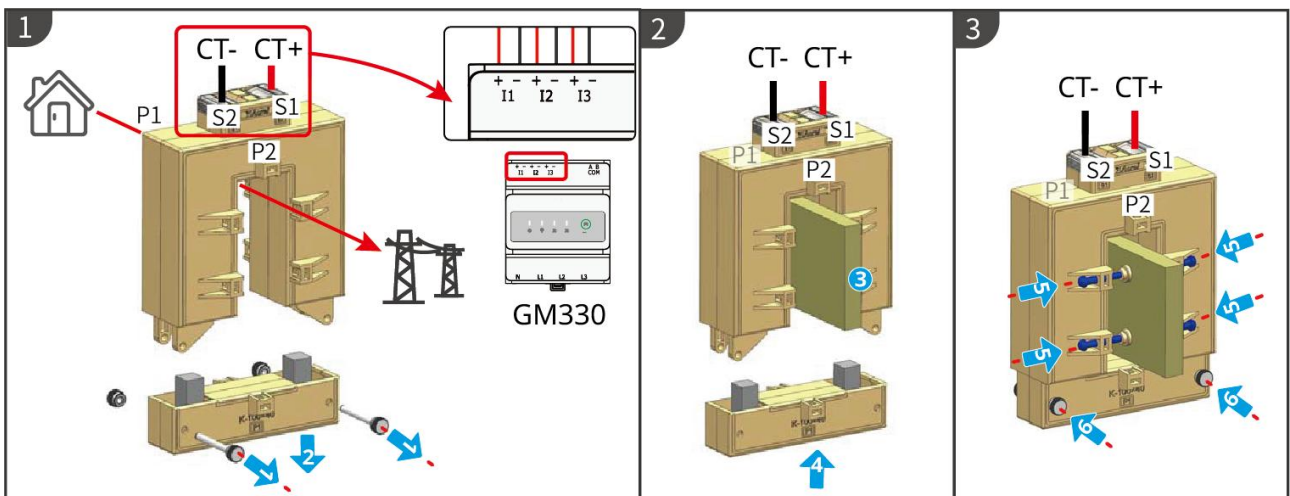

Installing the CT (Type II)

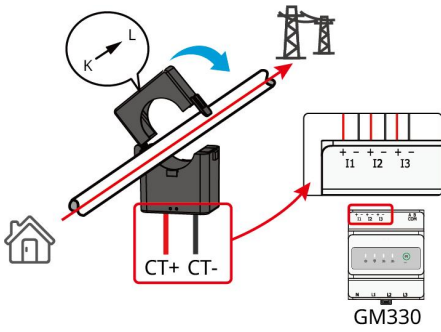

6.9 Connecting the Inverter Communication Cable

NOTICE

- The communication functions are optional. Connect the cables based on actual needs.
- Enable the DRED, RCR or remote shutdown function via SolarGo App after cable connections.
- If the inverter is not connected to the DRED device or remote shutdown device, do not enable these functions in the SolarGo App, otherwise the inverter cannot be connected to the grid for operation.
- To realize functions such as remote shutdown, DRED and RCR, the communication cable have to be connected to the master inverter. Otherwise, the functions cannot work properly.
- Signals connected to the DO communication port of the inverter should meet the specifications: Max \leq 24Vdc, 1A.
- EMS communication port: connects with the third party device. The third party device is not supported in a parallel system.
- To ensure waterproof protection, do not remove the waterproof seal of the unused ports.
- Recommended parallel communication cable length: CAT 5E or CAT 6E shielded Ethernet cables \leq 5m; CAT 7E shielded Ethernet cables \leq 10m. Ensure that the parallel communication cable does not exceed 10m, otherwise the communication may be abnormal.

Communication Descriptions

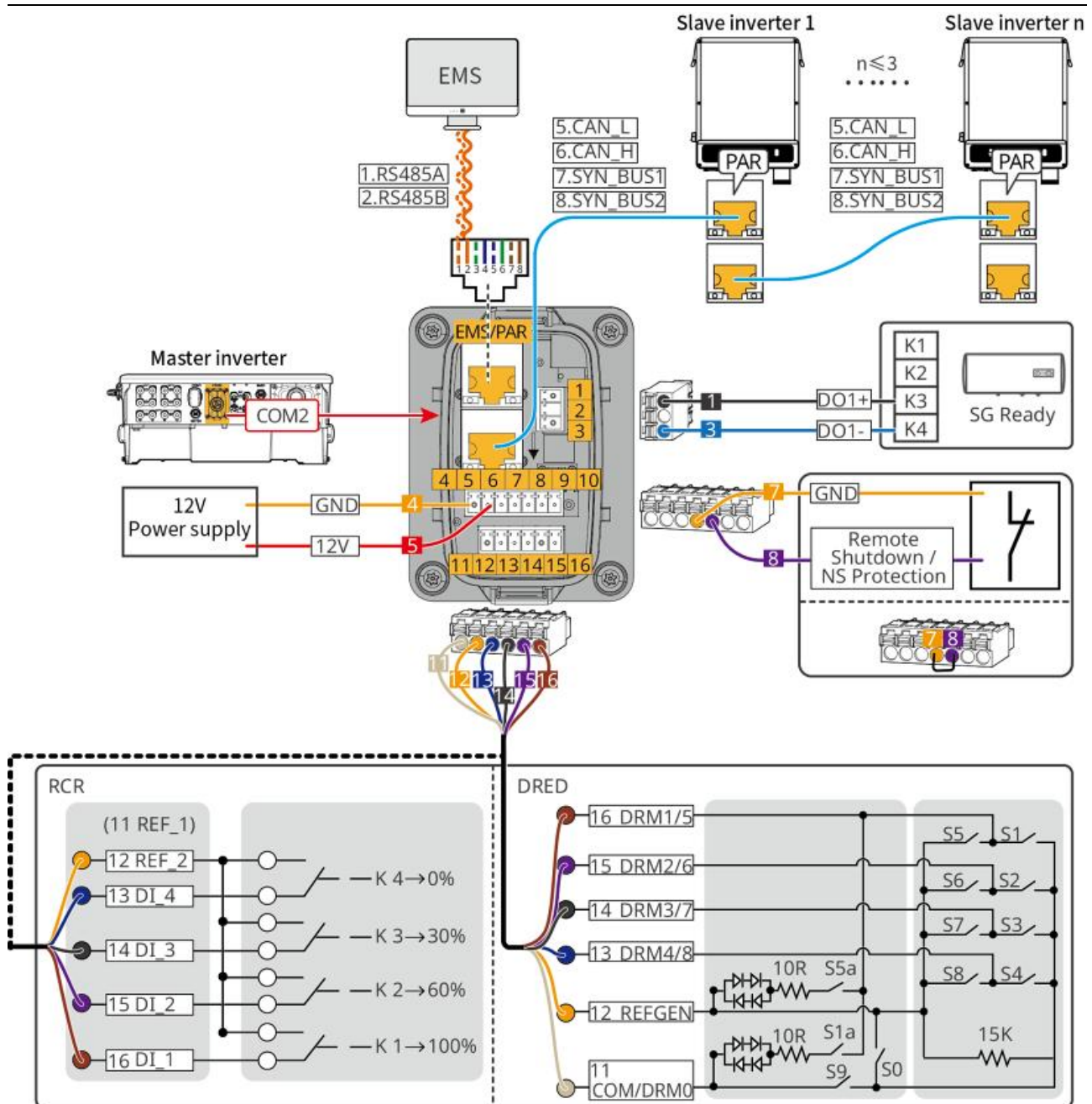

ET3010ELC0012

No.	Function	Description
1	Load Control (SG Ready)	<ul style="list-style-type: none"> Supports connecting to dry contact signals to realize functions such as load control. Switching capacity of DO is 12V DC@1A. NO/COM is the normally open contact. Supports SG Ready heat pump, which can be controlled by the dry contact signal. Supported working mode: <ul style="list-style-type: none"> Working mode 2 (signal: 0:0): energy saving mode, I the heat pump works in energy saving mode. Working mode 3 (signal: 0:1): the heat pump stores more hot water while working in the existing operation.
2	12V power supply	The inverter provides 12V power supply port and supports maximum 5W device. The port supports short-circuit protection.

3	Remote shutdown/NS Protection	<p>Provides signal control port to control equipment remote shutdown or realize NS protection function.</p> <ul style="list-style-type: none"> ● Control the device and stop it once any accident happens. ● The remote shutdown device should be normally closed contact. ● Before enabling RCR or DRED function, ensure that the remote shutdown device is connected or the remote shutdown port is short-circuited.
4	RCR or DRED	<ul style="list-style-type: none"> ● RCR (Ripple Control Receiver): the inverter satisfies Germany RCR certification and offers RCR signal controlling ports. ● DRED (Demand Response Enabling Device): the inverter satisfies the Australian DERD certification and offers DRED signal controlling ports.
5	EMS communication or parallel connection port	<ul style="list-style-type: none"> ● EMS communication port: connects with the third party device. The third party device is not supported in a parallel system. ● PAR communication port: serves as the communication port for the inverter parallelizing.

Connecting the communication cable

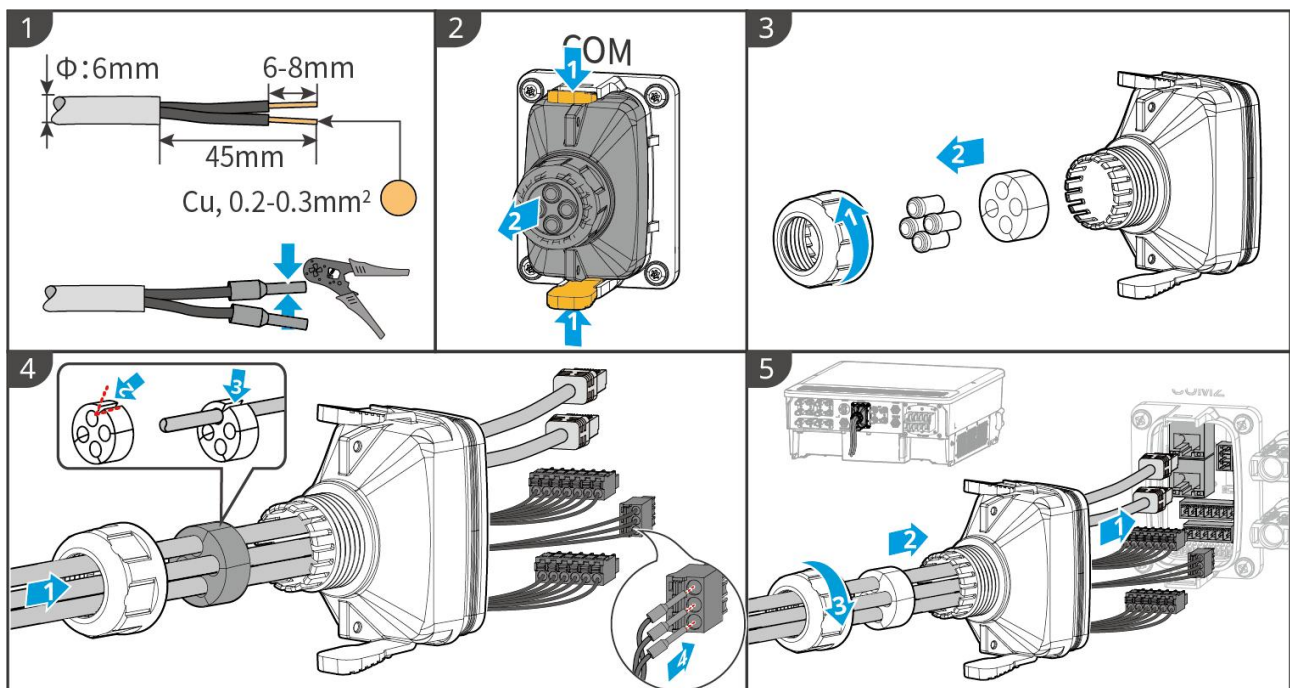

ET3010ELC0009

6.10 Connecting the Smart Dongle

NOTICE

- Plug a communication module into the inverter to establish a connection between the inverter and the smartphone or web pages. The communication module can be a Bluetooth module, WiFi module or LAN module. Set inverter parameters, check running

information and fault information, and observe system status in time via the smartphone or web pages.

- When multiple inverters are connected in a parallel system, the Ezlink3000 should be installed to the master inverter.
- WiFi-kit or WiFi/LAN Kit-20 can be used when there is only one inverter.
- Install a WiFi-kit, WiFi/LAN Kit-20, or Ezlink3000 when the inverter is connected to the router through WiFi.
- Install a WiFi/LAN Kit-20 or Ezlink3000 when the inverter is connected to the router through LAN.

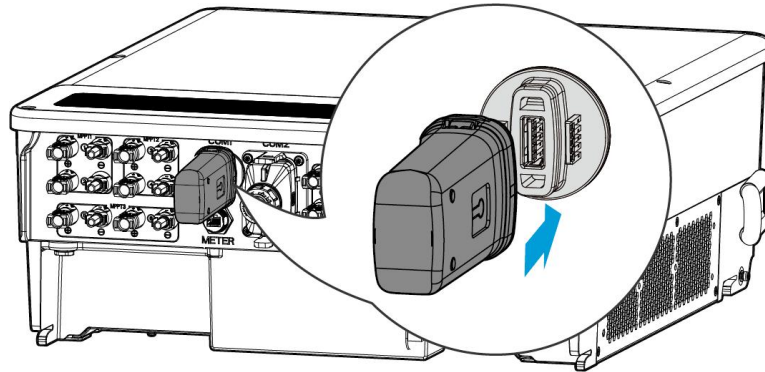

ET3010ELC0010

7 System Commissioning

7.1 Check Before Power ON

No.	Port Definition
1	The inverter is firmly installed in a clean place where is well-ventilated and easy to operate.
2	The PE, DC input, AC output, communication cables, and terminal resistors are connected correctly and securely.
3	Cable ties are intact, routed properly and evenly.
4	Unused cable holes are fitted using the waterproof nuts.
5	The used cable holes are sealed.
6	The voltage and frequency at the connection point meet the inverter grid connection requirements.

7.2 Power ON



WARNING

When power on the parallel system, make sure that all the AC breakers of the slave inverters are powered on within one minute after powering on the AC breaker of the master inverter.

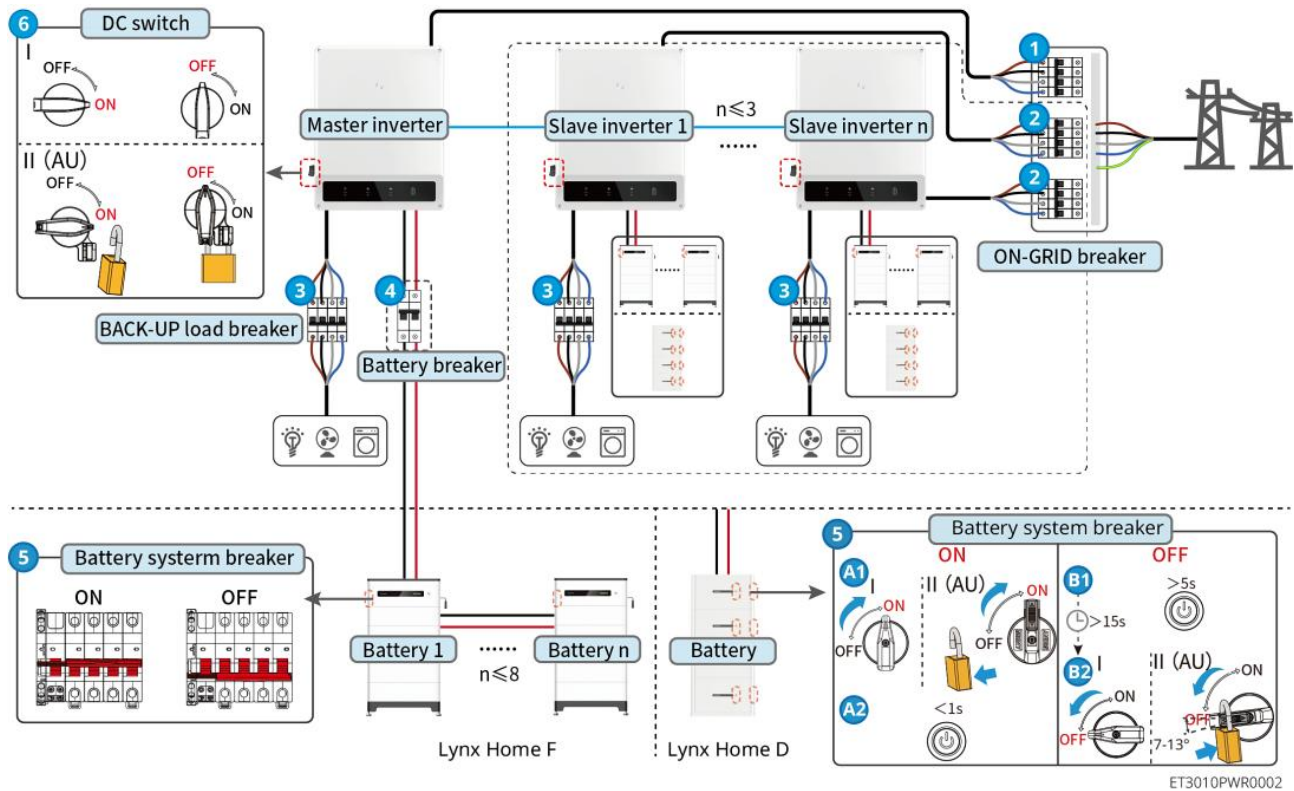











Power ON/OFF:



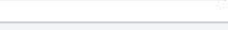

④: Optional in compliance with local laws and regulations.

7.3 Indicators

7.3.1 Inverter Indicators

Indicator	Status	Description
		The inverter is power on and in the standby mode.
		The inverter is starting and in self-check mode.
		The inverter is in normal operation under grid-tied or off-grid modes.
		BACK-UP output overload.

		System fault.
		The inverter is powered off.
		The grid is abnormal, and the power supply to the BACK-UP port of the inverter is normal.
		The grid is normal, and the power supply to the BACK-UP port of the inverter is normal.
		The BACK-UP port has no power supply.
		The monitoring module of the inverter is resetting.
		The inverter fails to connect with the communication Termination.
		Communication fault between the communication Termination and Server.
		The monitoring of the inverter operates well.
		The monitoring module of the inverter has not been started yet.







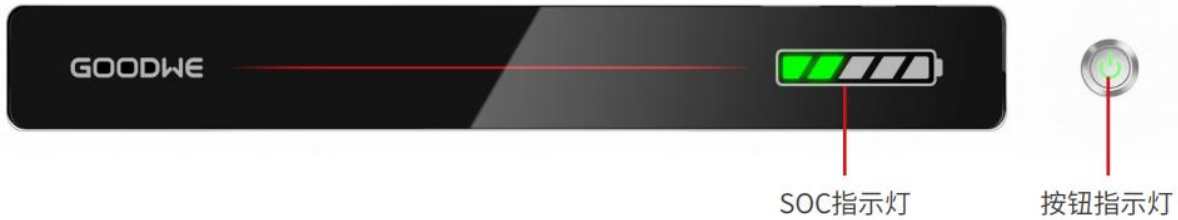

Indicator	Description
	$75% < SOC \leq 100%$
	$50% < SOC \leq 75%$
	$25% < SOC \leq 50%$
	$0% < SOC \leq 25%$
	No battery connected.
Indicator light blinking during battery discharging: for example, when the battery SOC is between 25% and 50%, the light at the 50% position blinks.	

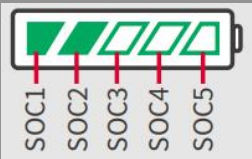
7.3.2 Battery Indicators

Lynx Home F



Normal status







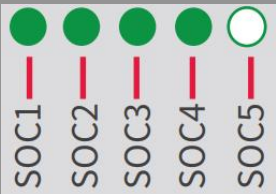

<p>SOC indicator</p> 	<p>Button Indicator</p> 	<p>Battery system status</p>
<p>SOC indicator indicates the battery percentage of the battery system.</p>  SOC < 5%  5% ≤ SOC < 25%  25% ≤ SOC < 50%  50% ≤ SOC < 75%  75% ≤ SOC < 95%  95% ≤ SOC ≤ 100%	<p>Green light blinks 1 time/s</p> <p>Green light blinks 2 time/s</p> <p>Green light steady on</p>	<p>The battery system is in standby mode.</p> <p>The battery system is in idle mode.</p> <p>The battery system is charging. Notice: When the battery SOC reaches the charging cutoff SOC, the battery will stop charging.</p>
<p>The last SOC indicator blinks 1 time/s.</p> <ul style="list-style-type: none"> ● When 5% ≤ SOC < 25%, SOC 1 blinks. ● When 25% ≤ SOC < 50%, SOC 2 blinks. ● When 50% ≤ SOC < 75%, SOC 3 blinks. ● When 75% ≤ SOC < 95%, SOC 4 blinks. ● When 95% ≤ SOC ≤ 100%, SOC 5 blinks. 	<p>Green light steady on</p>	<p>The battery system is in discharging status. Note: When the system does not need to supply power to the load or the battery SOC is below the set discharge depth, the battery will no longer discharge.</p>

Abnormal status

Button Indicator 	Battery system status	Description
Red light blink 1 time/s	Battery system alarm	Once an alarm occurs, the battery system will perform a self-check. After the battery system self-check is complete, the battery system enters operation or fault mode.
Red light steady on	Battery system fault	Check both the button indicator and the SOC indicator status to determine the fault that has occurred and handle the problem follow the methods recommended in the Troubleshooting section.

Lynx Home D

Normal status



SOC indicator 	Button Indicator 	Battery system status
SOC indicator indicates the battery percentage of the battery system. <ul style="list-style-type: none">  SOC<5%  5%≤SOC<25%  25%≤SOC<50%  50%≤SOC<75%  75%≤SOC<95%  95%≤SOC≤100% 	Green light blinks	The battery system is in standby mode.
	Green light steady on	The battery system is charging. Notice: When the battery SOC reaches the charging cutoff SOC, the battery will stop charging.
The last SOC indicator blinks 1 time/s. <ul style="list-style-type: none"> ● When 5%≤SOC<25%, SOC 1 blinks. ● When 25%≤SOC<50%, SOC 2 blinks. ● When 50%≤SOC<75%, SOC 3 blinks. ● When 75%≤SOC<95%, SOC 4 blinks. ● When 95%≤SOC≤100%, SOC 5 blinks. 	Green light steady on	The battery system is in discharging status. Note: When the system does not need to supply power to the load or the battery SOC is below the set discharge depth, the battery will no longer discharge.

Abnormal status





Button Indicator 	Battery system status	Description
Red light blinks	Battery system alarm	Once an alarm occurs, the battery system will perform a self-check. After the battery system self-check is complete, the battery system enters operation or fault mode. Check the alarm information through the SolarGo app.
Red light steady on	Battery system fault	Check both the button indicator and the SOC indicator status or SolarGo app to determine the fault that has occurred and handle the problem follow the methods recommended in the Troubleshooting section.

7.3.3 Smart Meter Indicator

GM3000



Type	Status	Description
Power indicator 	Steady on	The smart meter is power on.
	Off	The smart meter is power off.
Importing or exporting indicator 	Steady on	Importing from the grid.
	Blinks	Exporting to the grid.
Communication indicator 	Blinks	Communication is OK.
	Blinking 5 times	<ul style="list-style-type: none"> Press the Reset button for less than 3 seconds: Reset the meter. Press the Reset button for 5 seconds: Reset the meter parameters to factory settings. Press the Reset button for more than 10 seconds: Reset the meter parameters to factory settings, and reset the energy data to zero.
	Off	Meter has no communication connection.

GM330

Type	Status	Description
Power indicator 	Steady on	Power on, no RS485 communication.
	Blinks	Power on, RS485 communication works properly.
	Off	The smart meter is power off.
Communication indicator 	Off	Reserved
	Blinks	Press the Reset button for more than 5 seconds, power light, buying or selling electricity indicator light flash: Reset the meter.
Importing or exporting indicator 	Steady on	Importing from the grid.
	Blinks	Exporting to the grid.
	Off	Exporting to the grid.
	Reserved	









7.3.4 Smart Dongle Indicator

Wi-Fi Kit

Indicator	Color	Status	Description
Power 	Green	ON	The Wi-Fi Kit is powered on.
		OFF	The Wi-Fi Kit is restarting or not powered on.
COM 	Blue	ON	WiFi is connected to router.
		OFF	<ul style="list-style-type: none"> Improper communication on Wi-Fi Kit. The kit is restarting.

NOTICE

- Double click the Reload button to turn on the bluetooth signal, and the indicator turns to single flash. If there is no device connected to the Smart Dongle within 5 minutes, Bluetooth will automatically turn off.
- The indicator only turns to single flash after double clicking the Reload button.

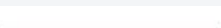

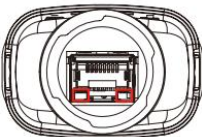



Indicator	Status	Description
Power 		Steady on The smart dongle is powered on.
		Off: The smart dongle is powered off.
COM 		Steady on The WiFi or LAN communication is working well.
		Single flash: The bluetooth signal of the Smart Dongle is on and waiting for connection to the app.
		Double blinks The Smart Dongle is not connected to the router.
		Four blinks The Smart Dongle is communicating with the router but not connected to the server.
		Six flashes: The Smart Dongle is recognizing the connected device.
		Off: The software of the Smart Dongle is in reset or not powered on.

Indicator	Color	Status	Description
Communication indicator in LAN Port 	Green	Steady on	The connection of the wired network at 100Mbps is normal.
		OFF	<ul style="list-style-type: none"> ● The Ethernet cable is not connected. ● The connection of the wired network at 100Mbps is abnormal. ● The connection of the wired network at 10Mbps is normal.
	Yellow	Steady on	The connection of the wired network at 10Mbps is normal, but no communication data is received or transmitted.

		Blinks	The communication data is being transmitted or received.
		OFF	The Ethernet cable is not connected.

Button	Description
Reload	Press and hold for 0.5 to 3 seconds to reset the Smart Dongle.
	Press and hold for 6 to 20 seconds to restore the Smart Dongle to factory settings.
	Double click to turn on the bluetooth signal (lasts only 5 minutes).

Ezlink3000

Indicator/si lkscreen	Color	Status	Description
Power 	Blue		Blink = The Ezlink3000 is working properly.
			OFF = The Ezlink3000 is powered off.
COM 	Green		ON = The Ezlink3000 is connected to the server.
			Blink 2 = The Ezlink3000 is not connected to the router.
			Blink 4 = The Ezlink3000 is connected to the router, but not connected to the server.
RELOAD	-	-	<ul style="list-style-type: none"> ● Short press for 3s to restart the Ezlink3000. ● Long press for 3-10s to restore factory settings.

8 Quick System Commissioning

8.1 Downloading the App

Make sure that the mobile phone meets the following requirements:

- Mobile phone operating system: Android 4.3 or later, iOS 9.0 or later.
- The mobile phone can access the Internet.
- The mobile phone supports WLAN or Bluetooth.

Method 1: Search SolarGo in Google Play (Android) or App Store (iOS) to download and install the app.



Method 2: Scan the QR code below to download and install the app.

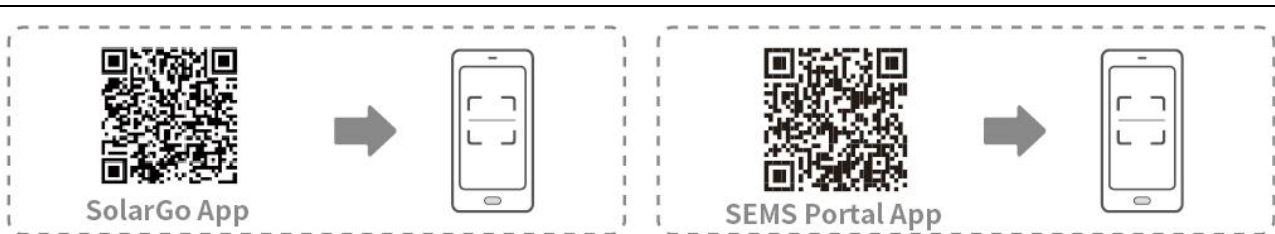

8.2 Connecting the Inverter

NOTICE

The device name varies depending on the inverter model or smart dongle type:

- Wi-Fi Kit: Solar-WiFi***
- Bluetooth module: Solar-BLE***
- WiFi/LAN Kit-20: WLA-***
- Ezlink3000: CCM-BLE***; CCM-***; ***

Connecting the inverter via bluetooth

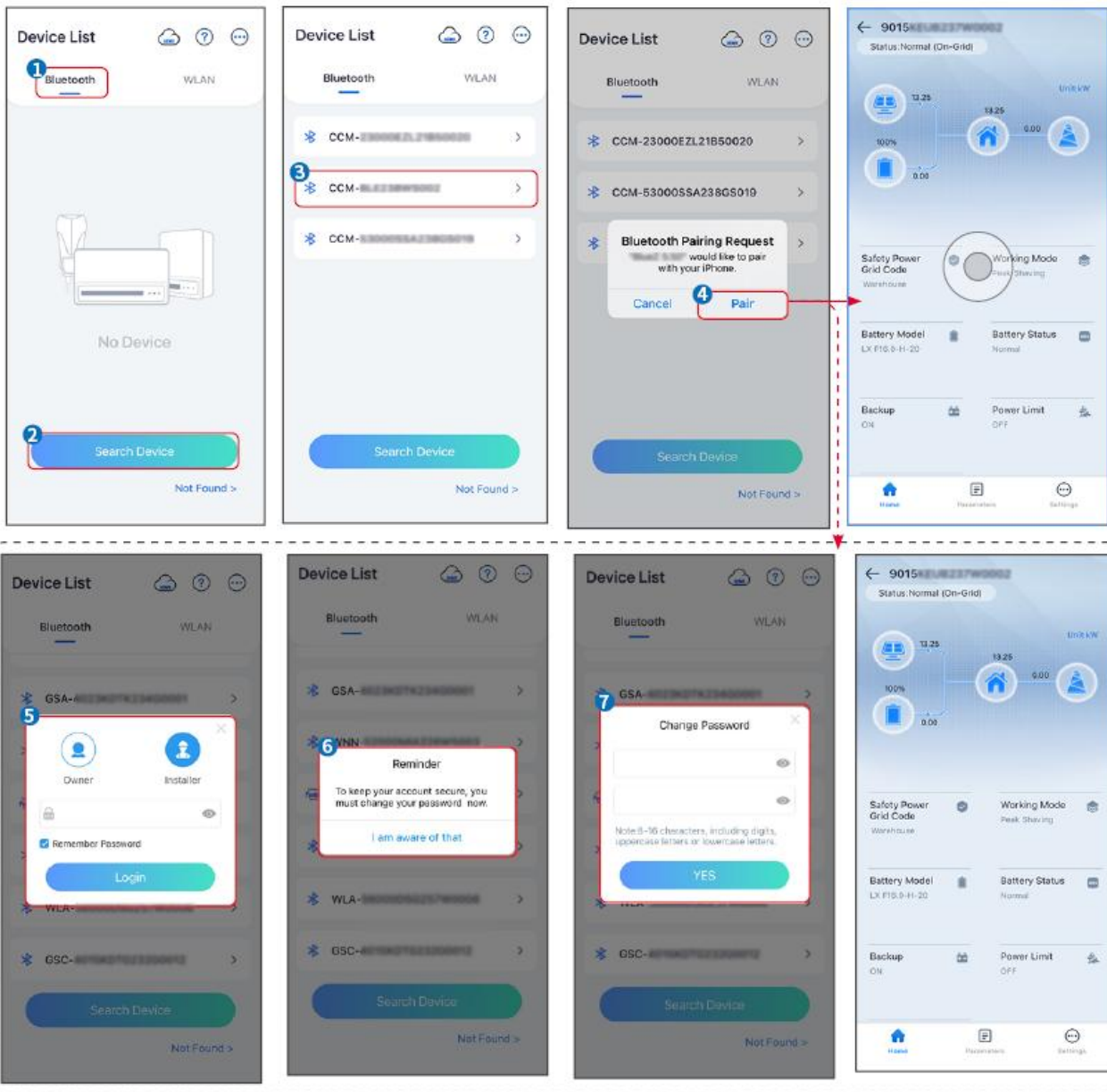

Connecting the inverter via WiFi

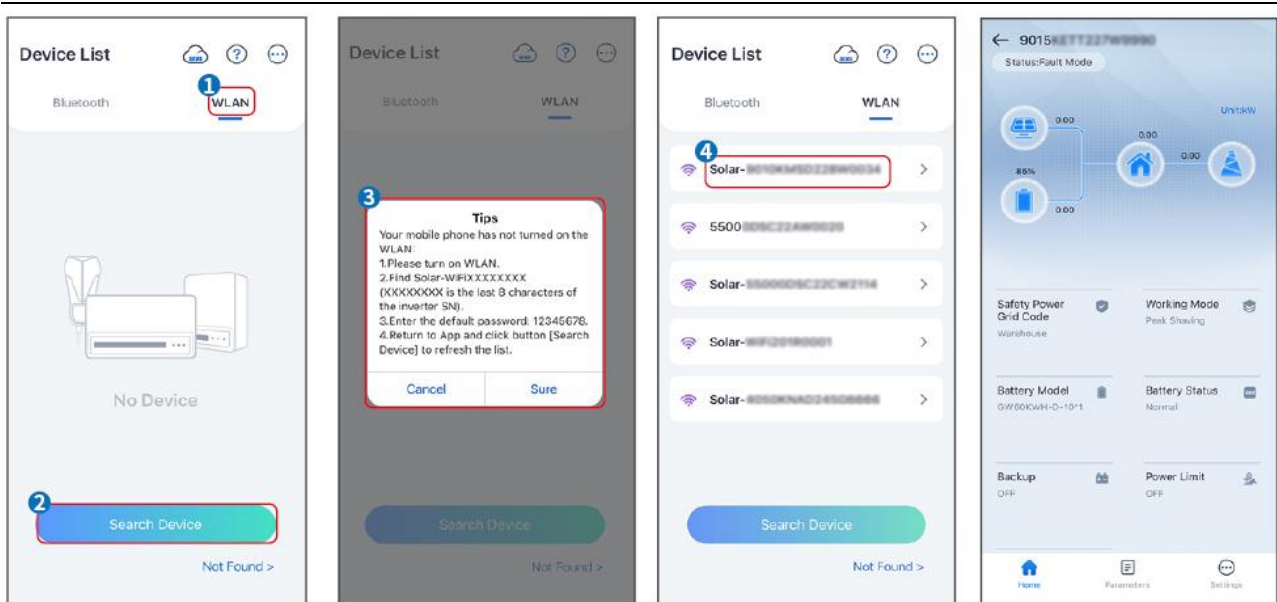

8.3 Communication Settings

NOTICE

The communication configuration interface varies depending on the communication method.

Step 1: Tap **Home** > **Settings** > **Communication Settings** > **WLAN/LAN**, to set the parameters.

Step 2: Set the WLAN or LAN parameters based on actual situation.

No.	Name/Icon	Description
1	Network Name	Only for WLAN. Select WiFi based on the actual connecting.
2	Password	Only for WLAN. WiFi password for the actual connected network.
3	DHCP	<ul style="list-style-type: none"> ● Enable DHCP when the router is in dynamic IP mode. ● Disable DHCP when a switch is used or the router is in static IP mode.
4	IP Address	<ul style="list-style-type: none"> ● Do not configure the parameters when DHCP is enabled. ● Configure the parameters according to the router or switch information when DHCP is disabled.
5	Subnet Mask	
6	Gateway Address	
7	DNS Server	

8.4 Quick Settings

NOTICE

- The parameters will be configured automatically after selecting the safety country/region, including overvoltage protection, undervoltage protection, overfrequency protection, underfrequency protection, voltage/frequency connection protection, $\cos\phi$ curve, Q(U) curve, P(U) curve, FP curve, HVRT, LVRT, etc.
- The power generation efficiency is different in different working modes. Set the working mode according to the local requirements and situation.

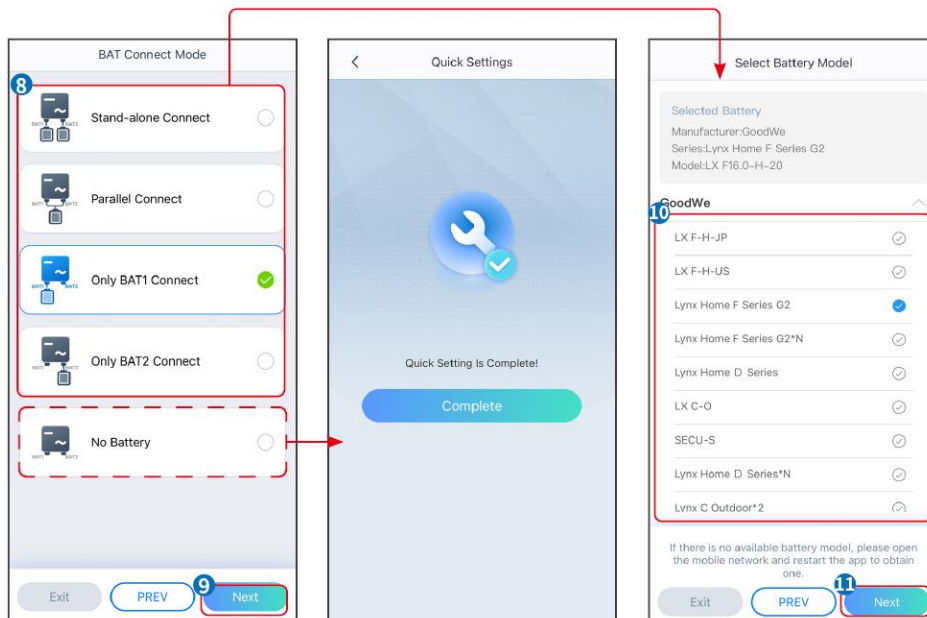
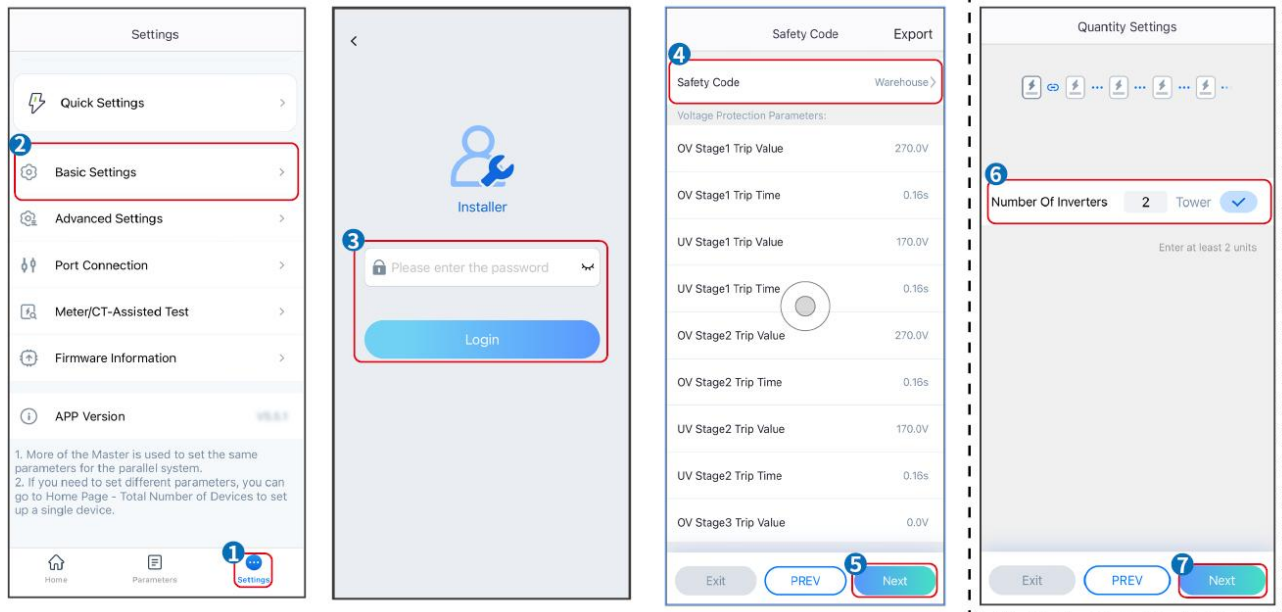

Parameters	Description
Safety Code	Select safety country accordingly.
Quantity Settings	In parallel scenarios, set the number of inverters in the parallel system based on actual situation.

BAT Connect Mode	Select the actual mode in which the battery is connected to the inverter. No need to set the battery model and working mode if there is no battery is connected. The system will work in self-use mode by default.
Select Battery Model	Select the actual battery model.
Working Mode	Set the working mode based on actual needs. Supports: Peakshaving mode and Self-use mode.

The app interface is as following when Self-use mode is selected. Enter Advanced Settings to set the detailed working mode and related parameters.

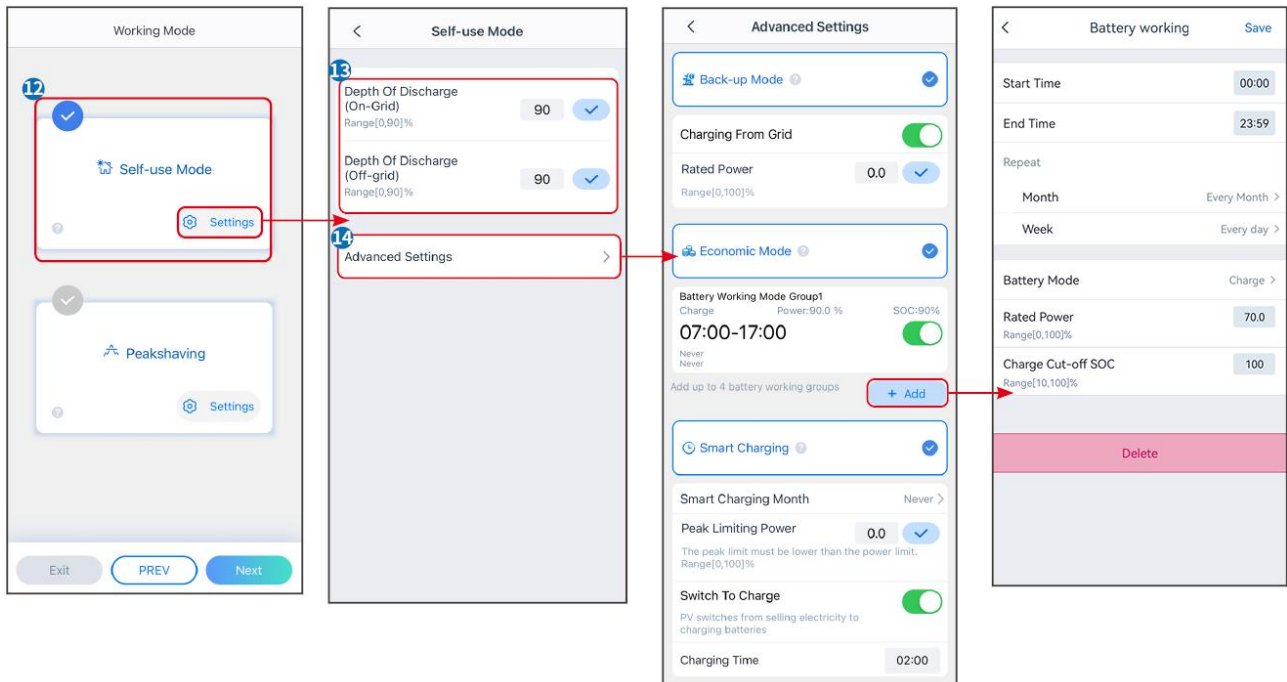

Parameters	Description
Self-use mode: based on the self-use mode, Back-up mode, Economic mode, and Smart charging can be enabled at the same time, and the inverter will automatically select the working mode. Working priority: Back-up mode> Economic mode >Smart charging	
Depth Of Discharge (On-Grid)	The maximum depth of discharge of the battery when the system is working on-grid.
Depth Of Discharge (Off-grid)	The maximum depth of discharge of the battery when the system is working off-grid.
Back-up mode	
Charging From Grid	Enable Charging From Grid to allow power purchasing from the utility grid.
Rated Power	The percentage of the purchasing power to the rated power of the inverter.

Economic mode	
Start Time	Within the Start Time and End Time, the battery is charged or discharged according to the set Battery Mode as well as the Rated Power.
End Time	
Battery Mode	Set the Battery Mode to Charging or Discharging accordingly.
Rated Power	The percentage of the charging/discharging power to the rated power of the inverter.
Charge Cut-off SOC	The battery stop charging/discharging once the battery SOC reaches Charge Cut-off SOC.
Smart charging	
Smart Charging Month	Set the smart charging months. More than one month can be set.
Peak Limiting Power	Set the Peak Limiting Power in compliance with local laws and regulations. The Peak Limiting Power shall be lower than the output power limit specified by local requirements.
Switch to Charge	During charging time, the PV power will charge the battery.

The app interface is as following when Peakshaving mode is selected.

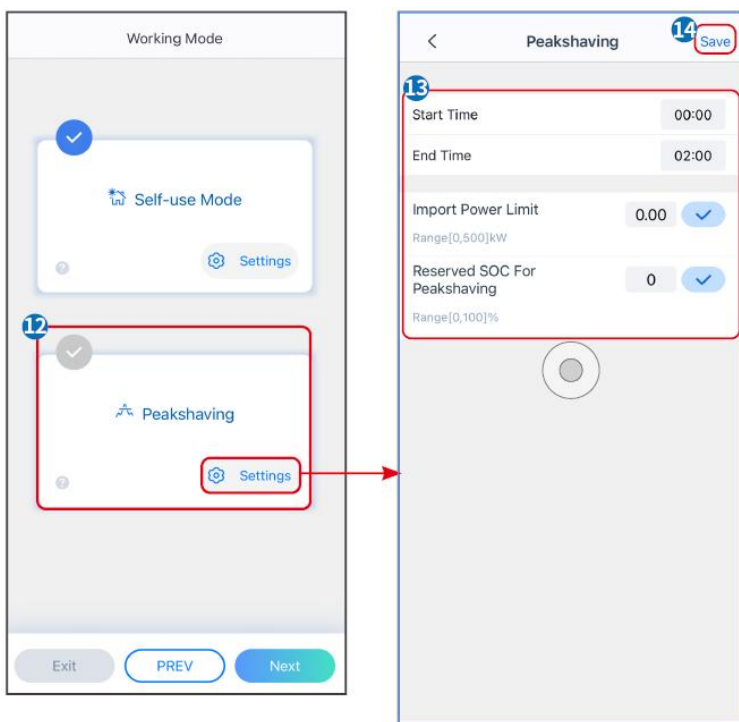

Parameters	Description
Peakshaving	
Start Time	The utility grid will charge the battery between Start Time and End

End Time	Time if the load power consumption do not exceed the power quota. Otherwise, only PV power can be used to charge the battery.
Import Power Limit	Set the maximum power limit allowed purchase from the grid. When the loads consume power exceed the sum of the power generated in the PV system and Import Power Limit , the excess power will be made up by the battery.
Reserved SOC For Peakshaving	In Peak Shaving mode, the battery SOC should be lower than Reserved SOC For Peakshaving. Once the battery SOC is higher than Reserved SOC For Peakshaving, the peak shaving mode fails.

Tap **Complete** to complete the settings, restart the equipment following the prompts.

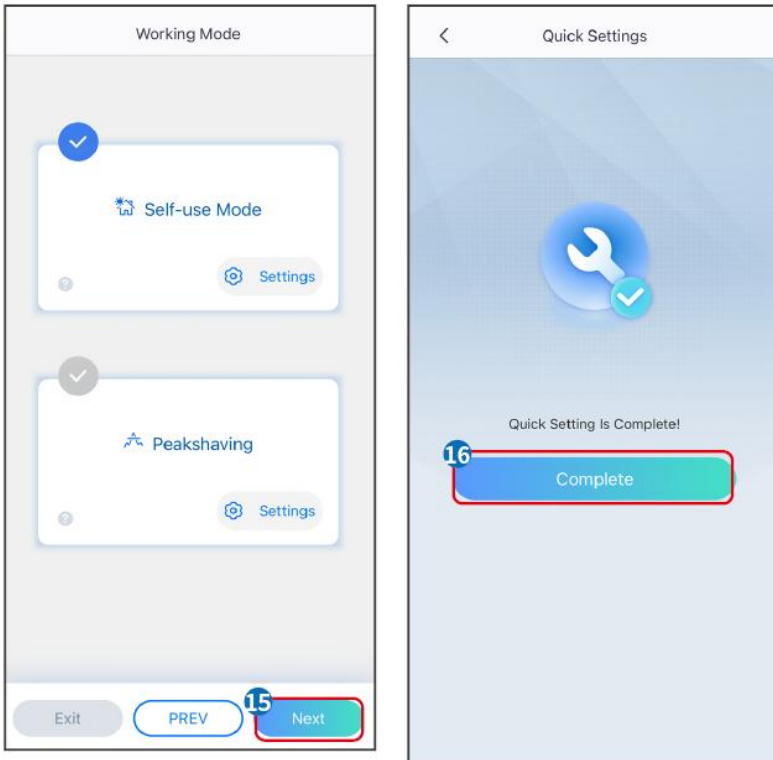

8.5 Creating Power Plants

NOTICE

Login to the SEMS Portal app using the account and password before creating power plants. If you have any questions, refer to the Plant Monitoring section.

Step 1 Enter the **Create Plant** page.

Step 2 Read the instructions and fill in the requested plant information based on actual situation. (* refers to the mandatory items)

Step 3 Follow the prompts to add devices and create the plant.

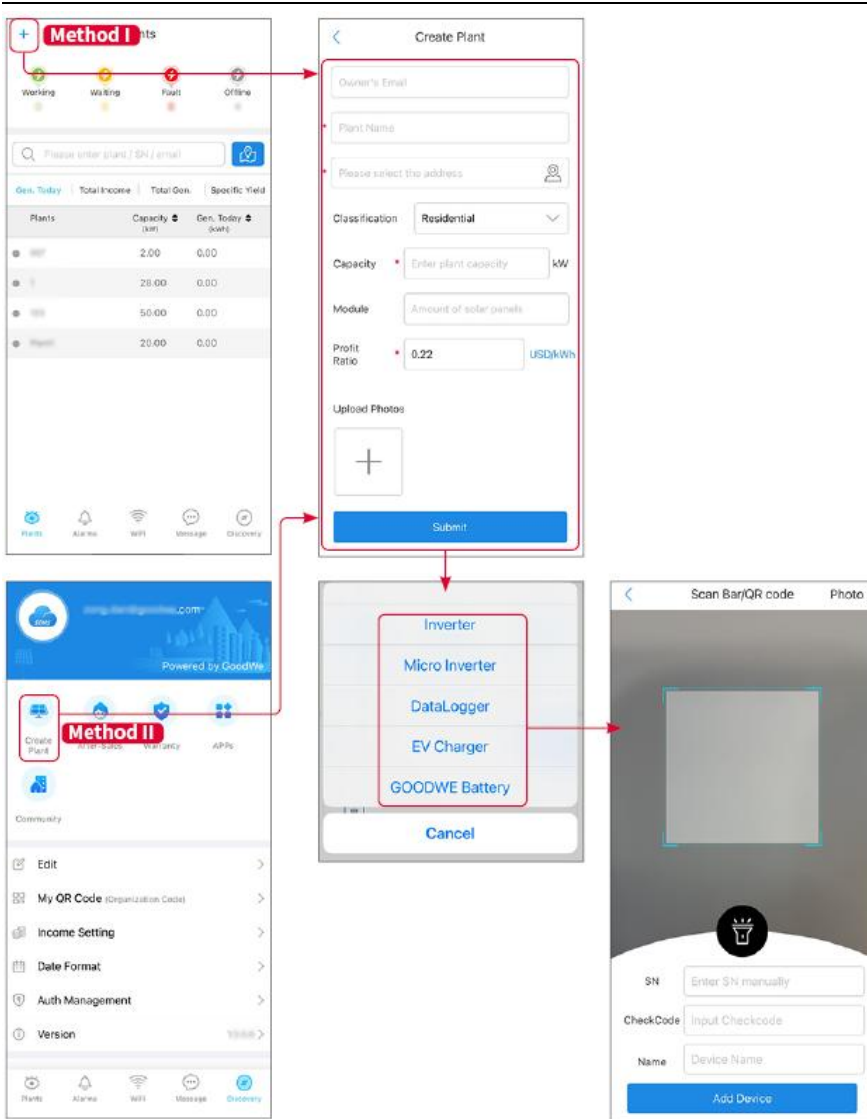

9 System Commissioning

9.1 SolarGo Overview

SolarGo App is a mobile application that communicates with the inverter through bluetooth or WiFi modules. Commonly used functions are as follows:

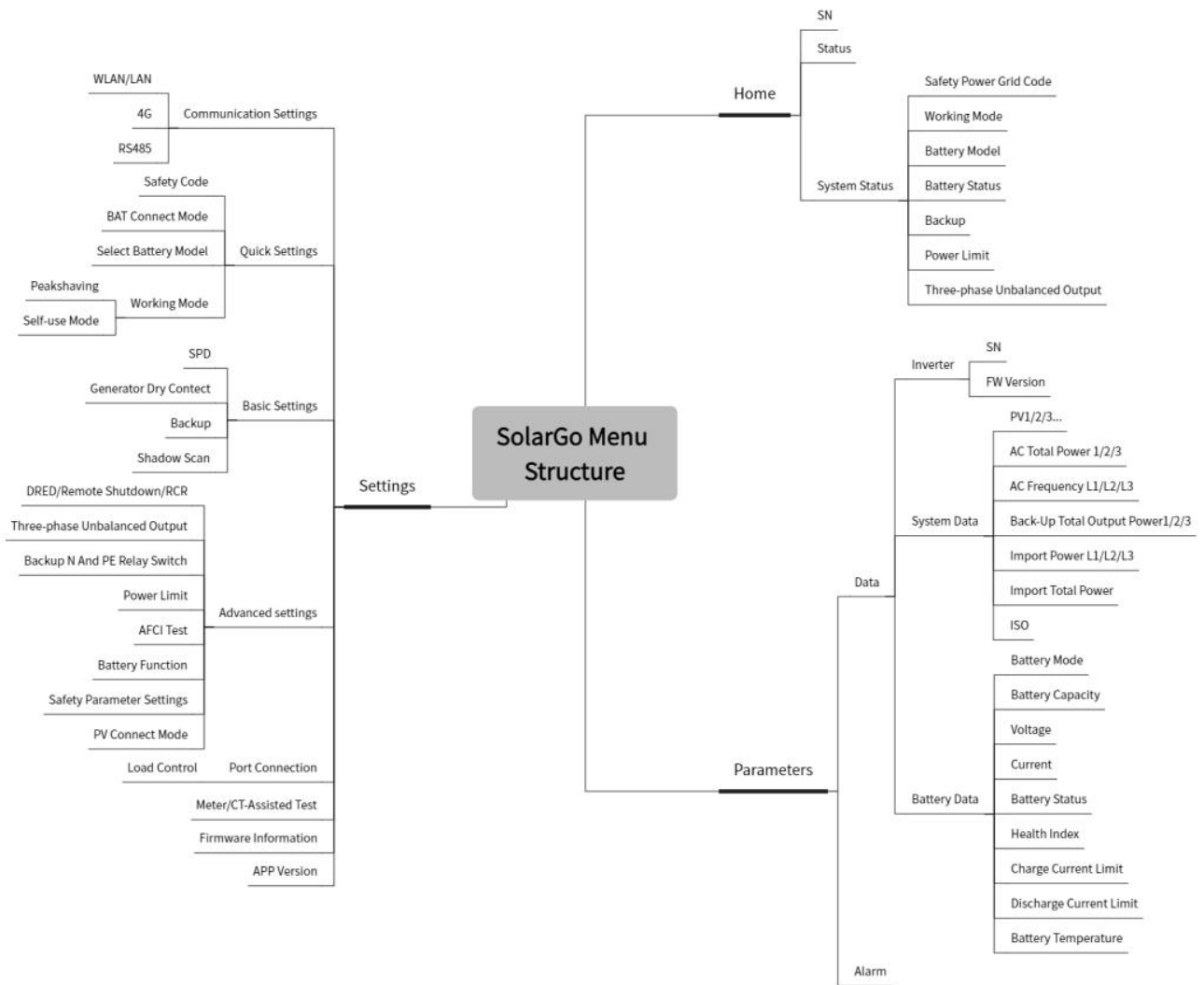

1. Check the operating data, software version, alarms, etc.
2. Set grid parameters, communication parameters, safety countries, power limitation, etc.
3. Equipment maintenance.
4. Upgrade the firmware version of the equipment.

9.1.1 Menu Structure of the App

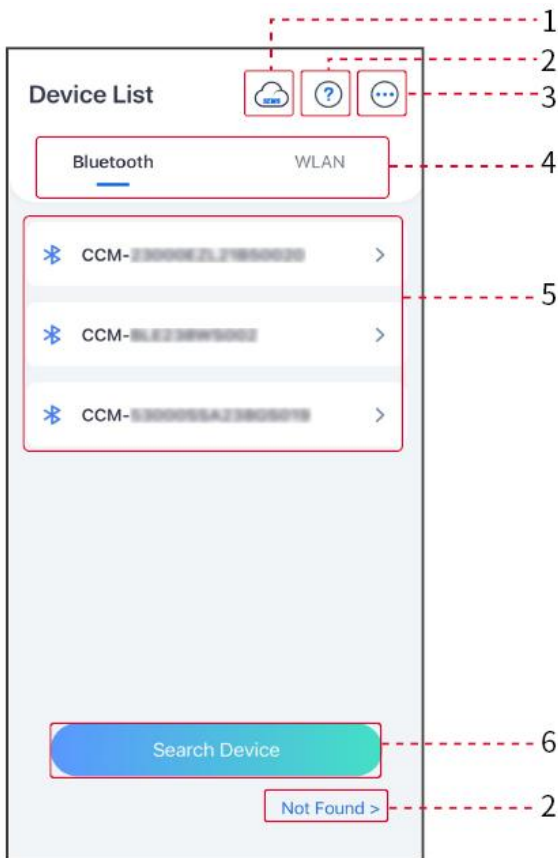

9.1.2 Login Page of SolarGo App





No.	Name/Icon	Description
1		Tap the icon to open the page downloading the SEMS Portal app.
2		Tap to read the connection guide.
	Not found	
3		<ul style="list-style-type: none"> ● Check information such as app version, local contacts, etc. ● Other settings, such as update date, switch language, set temperature unit, etc.
4	Bluetooth/ WLAN	Select based on actual communication method. If you have any problems, tap or NOT Found to read the connection guides.
5	Device List	<ul style="list-style-type: none"> ● The list of all devices. The last digits of the device name are normally the serial number of the device. ● Select the device by checking the serial number of the master inverter when multi inverters are parallel connected. ● The device name varies depending on the inverter model or communication module.

6	Search Device	Tap Search Device if the device is not found.
---	---------------	--

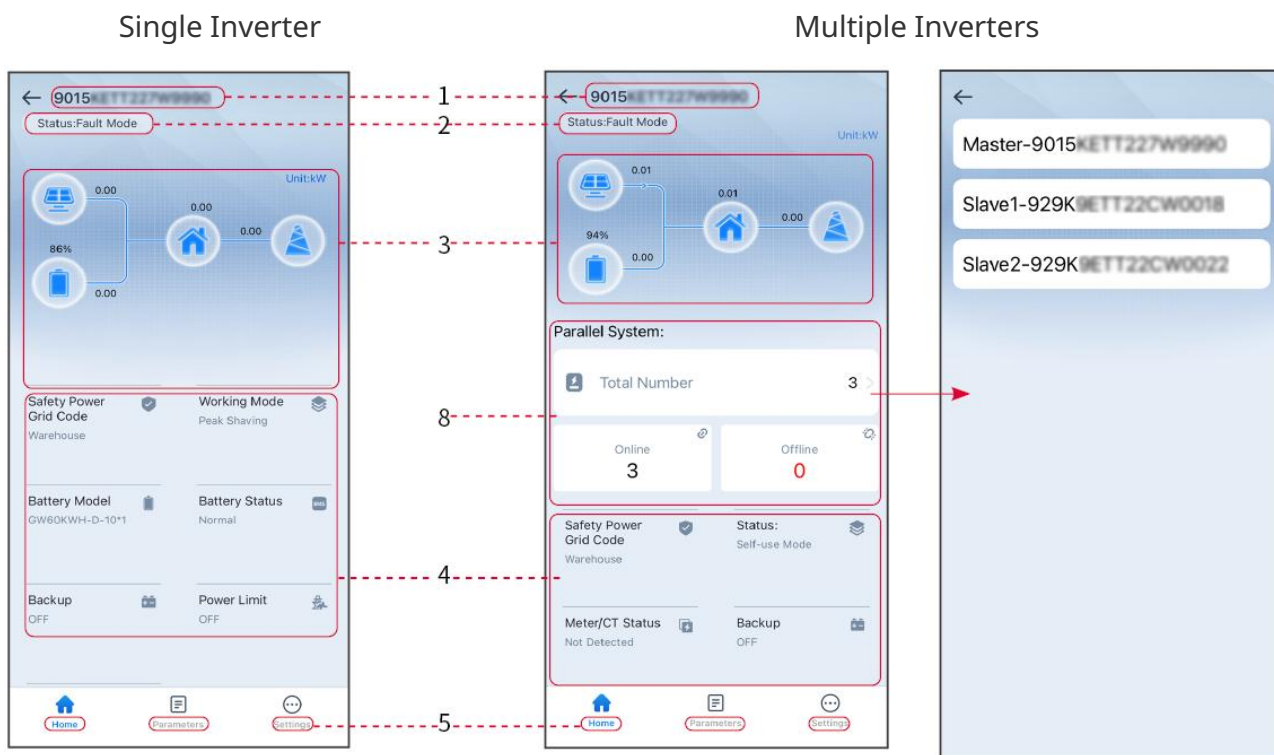
9.1.3 Home Page of SolarGo App



No.	Name/Icon	Description
1	Serial Number	Serial number of the connected inverter or serial number of the master inverter in the parallel system.
2	Device Status	Indicates the status of the inverter, such as Working, Fault, etc.
3	Energy Flow Chart	Indicates the energy flow chart of the PV system. The actual page prevails.
4	System Status	Indicates the system status, such as Safety Code, Working Mode, Battery Model, Battery Status, Power Limit, Three-Phase Unbalanced Output, etc.
5	 Home	Home. Tap Home to check Serial Number, Device Status, Energy Flow Chart, System Status, etc.
6	 Parameters	Parameters. Tap Parameters to check the running parameters of the system.

7	 Settings	Settings. Log in before entering Quick Settings and Advanced Settings. Initial password: goodwe2010 or 1111.
8	Parallel	Tap Total Number to check serial number of all inverters. Tap the serial number to enter the setting page of the single inverter.

9.2 Connecting the Inverter to SolarGo App

NOTICE

The device name varies depending on the inverter model or communication module:

- Wi-Fi Kit: Solar-WiFi***
- Bluetooth module: Solar-BLE***
- WiFi/LAN Kit-20: WLA-***
- Ezlink3000: CCM-BLE***; CCM-***; ***

Connecting the inverter via bluetooth

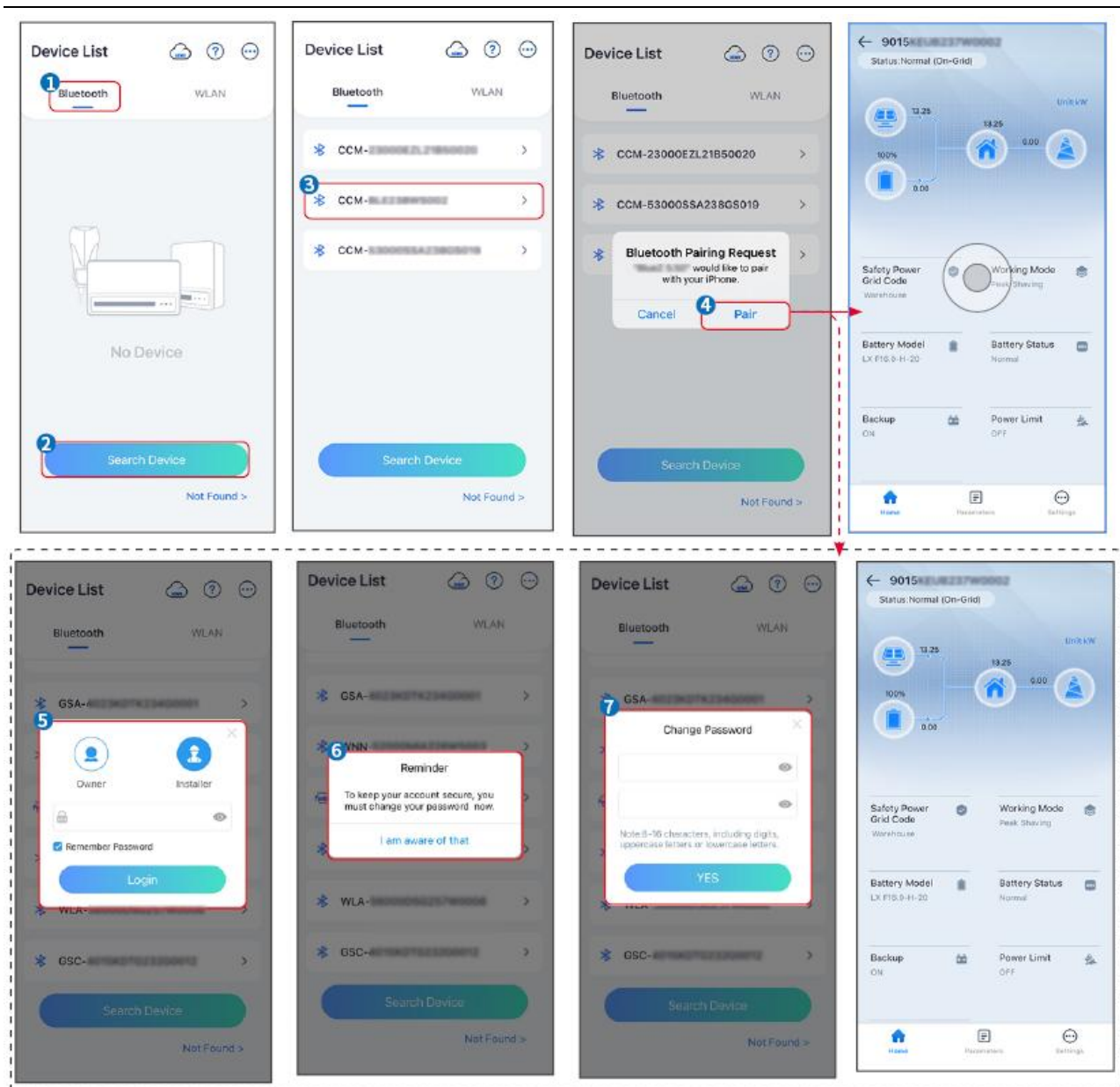

Connecting the inverter via WiFi

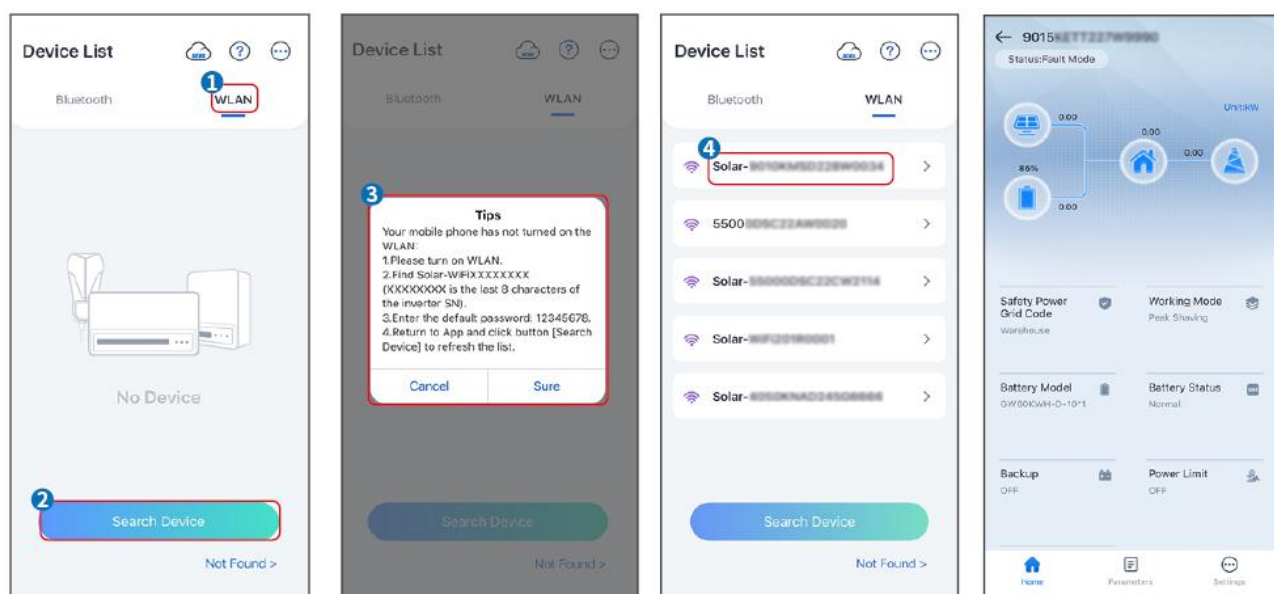

9.3 Communication Settings

NOTICE

The communication configuration page varies depending on the communication method.

Setting Privacy and Security

Type I

Step 1 Tap **Home > Settings > Communication Setting > Privacy & Security** to set the parameters.

Step 2 Set the new password for the WiFi hotspot of the communication module, and tap **Save**.

Step 3 Open the WiFi settings of your phone and connect to the inverter's WiFi signal (SolarWiFi***) with the new password.

Type II

Step 1 Tap **Home > Settings > Communication Setting > Privacy & Security** to set the parameters.

Step 2 Enable Bluetooth Stays On or WLAN Control based on actual needs.

Setting WLAN/LAN Parameters

Step 1 Tap **Home > Settings > Communication Setting > Network Settings** to set the parameters.

Step 2 Set the WLAN or LAN parameters based on actual situation.

No.	Name/Icon	Description
1	Network Name	Only for WLAN. Select WiFi based on the actual connecting.
2	Password	Only for WLAN. WiFi password for the actual connected network.
3	DHCP	<ul style="list-style-type: none"> ● Enable DHCP when the router is in dynamic IP mode. ● Disable DHCP when a switch is used or the router is in static IP mode.
4	IP Address	<ul style="list-style-type: none"> ● Do not configure the parameters when DHCP is enabled. ● Configure the parameters according to the router or switch information when DHCP is disabled.
5	Subnet Mask	
6	Gateway Address	
7	DNS Server	

9.4 Quick Settings

NOTICE

- The parameters will be configured automatically after selecting the safety country/region, including overvoltage protection, undervoltage protection, overfrequency protection, underfrequency protection, voltage/frequency connection protection, $\cos\phi$ curve, Q(U) curve, P(U) curve, FP curve, HVRT, LVRT, etc.
- The power generation efficiency is different in different working modes. Set the working mode according to the local requirements and situation.

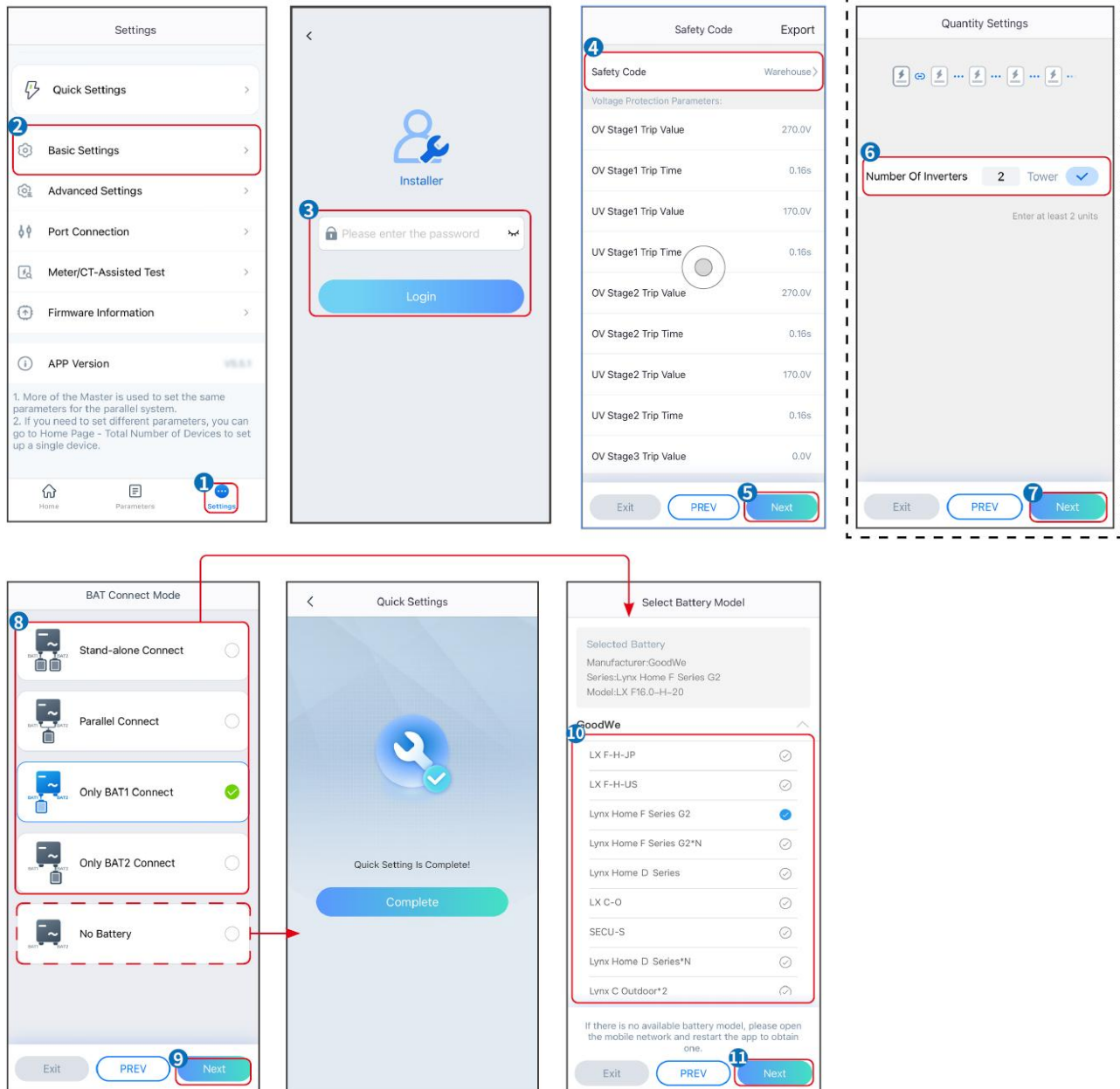

Parameters	Description
Safety Code	Select safety country accordingly.

Quantity Settings	In parallel scenarios, set the number of inverters in the parallel system based on actual situation.
BAT Connect Mode	Select the actual mode in which the battery is connected to the inverter. No need to set the battery model and working mode if there is no battery is connected. The system will work in self-use mode by default.
Select Battery Model	Select the actual battery model.
Working Mode	Set the working mode based on actual needs. Supports: Peakshaving mode and Self-use mode.

The app interface is as following when Self-use mode is selected. Enter Advanced Settings to set the detailed working mode and related parameters.

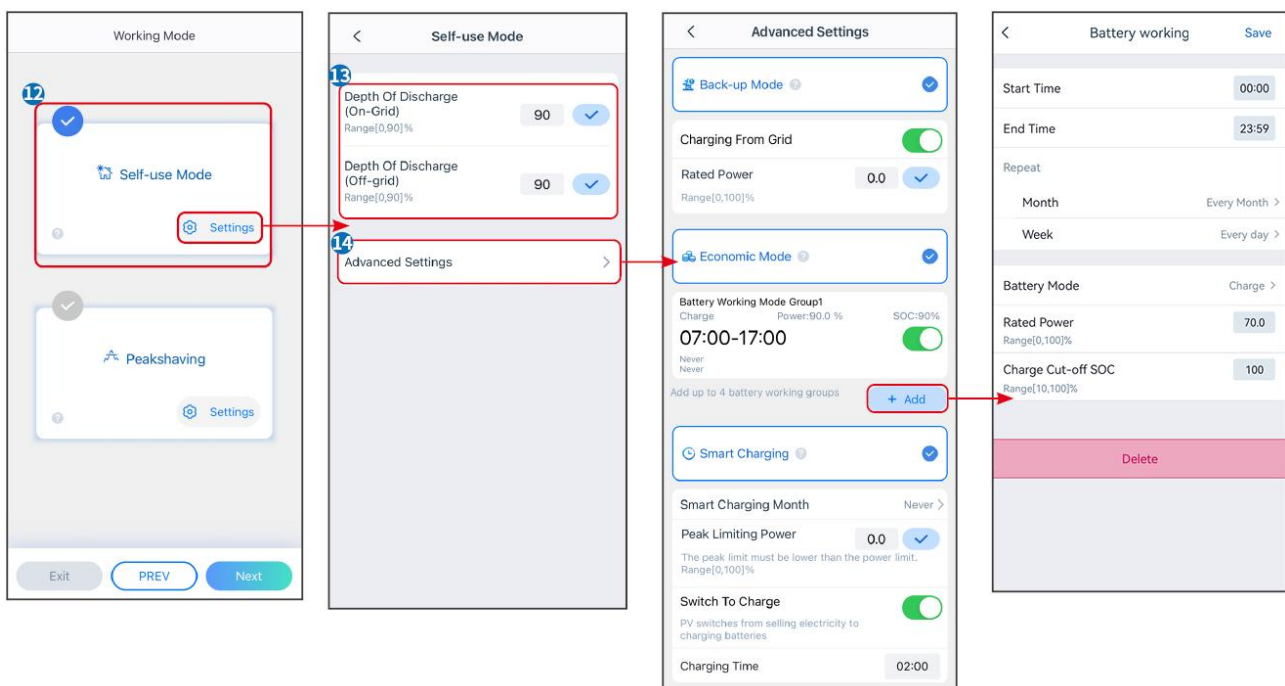

Parameters	Description
Self-use mode: based on the self-use mode, Back-up mode, Economic mode, and Smart charging can be enabled at the same time, and the inverter will automatically select the working mode. Working priority: Back-up mode> Economic mode >Smart charging	
Depth Of Discharge (On-Grid)	The maximum depth of discharge of the battery when the system is working on-grid.
Depth Of Discharge (Off-grid)	The maximum depth of discharge of the battery when the system is working off-grid.
Back-up mode	
Charging From Grid	Enable Charging From Grid to allow power purchasing from the utility grid.
Rated Power	The percentage of the purchasing power to the rated power of the inverter.
Economic mode	

Start Time	Within the Start Time and End Time, the battery is charged or discharged according to the set Battery Mode as well as the Rated Power.
End Time	
Battery Mode	Set the Battery Mode to Charging or Discharging accordingly.
Rated Power	The percentage of the charging/discharging power to the rated power of the inverter.
Charge Cut-off SOC	The battery stop charging/discharging once the battery SOC reaches Charge Cut-off SOC.
Smart charging	
Smart Charging Month	Set the smart charging months. More than one month can be set.
Peak Limiting Power	Set the Peak Limiting Power in compliance with local laws and regulations. The Peak Limiting Power shall be lower then the output power limit specified by local requirements.
Switch to Charge	During charging time, the PV power will charge the battery.

The app interface is as following when Peakshaving mode is selected.

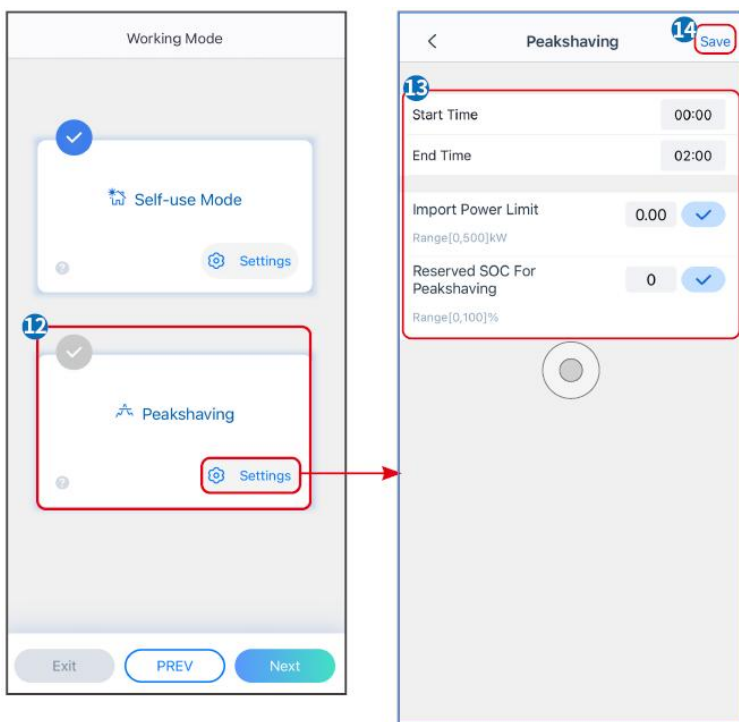

Parameters	Description
Peakshaving	
Start Time	The utility grid will charge the battery between Start Time and End Time if the load power consumption do not exceed the power quota. Otherwise, only PV power can be used to charge the battery.
End Time	

Import Power Limit	Set the maximum power limit allowed to purchase from the grid. When the loads consume power exceed the sum of the power generated in the PV system and Import Power Limit , the excess power will be made up by the battery.
Reserved SOC For Peakshaving	In Peak Shaving mode, the battery SOC should be lower than Reserved SOC For Peakshaving. Once the battery SOC is higher than Reserved SOC For Peakshaving, the peak shaving mode fails.

Tap **Complete** to complete the settings, restart the equipment following the prompts.

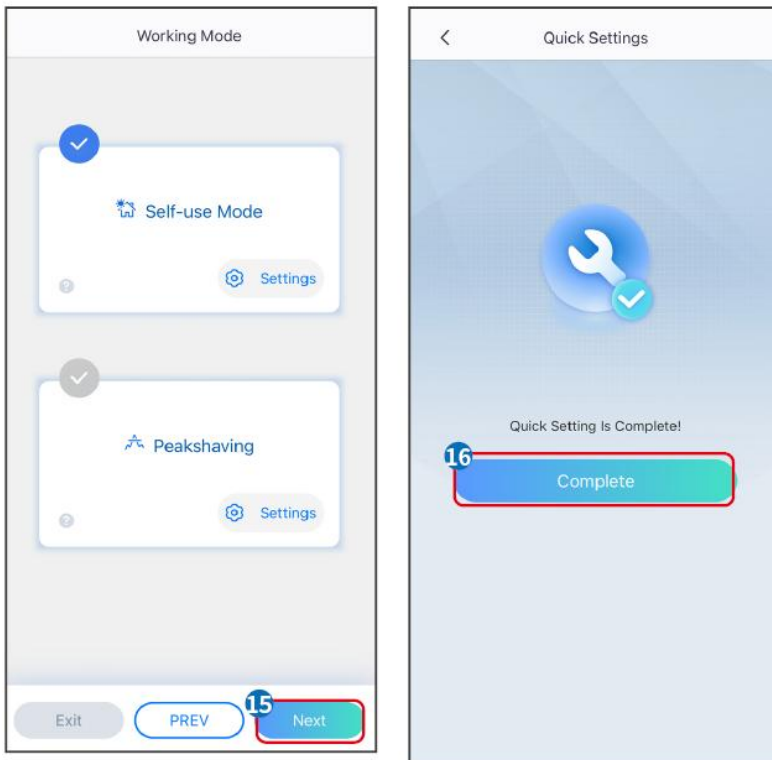

9.5 Setting the Basic Information

9.5.1 Setting Shadow Scan and SPD

Step 1 Tap **Home** > **Settings** > **Basic Settings**, to set the parameters.

Step 2 Set the functions based on actual needs.

Shadow Scan and SPD

No.	Parameters	Description
1	Shadow Scan	Enable Shadow Scan when the PV panels are severely shadowed to optimize the power generation efficiency.
2	SPD	After enabling SPD , when the SPD module is abnormal, there will be SPD module abnormal

		alarm prompt.
--	--	---------------

9.5.2 Setting the Backup Function

After enabling **Backup**, the battery will power the load connected to the backup port of the inverter to ensure Uninterrupted Power Supply when the power grid fails.

No.	Parameters	Description
1	UPS Mode - Full Wave Detection	Check whether the utility grid voltage is too high or too low.
2	UPS Mode - Half Wave Detection	Check whether the utility grid voltage is too low.
3	EPS Mode - Supports LVRT	Stop detecting utility grid voltage.
4	First Cold Start (Off-grid)	Take effect once. In off-grid mode, enable First Cold Start (Offgrid) to output backup supply with battery or PV.
5	Cold Start Holding	Take effect multiple times. In off-grid mode, enable First Cold Start (Off-grid) to output backup supply with battery or PV.
6	Clear Overload History	Once the power of loads connected to the inverter BACK-UP ports exceeds the rated load power, the inverter will restart and detect the power again. The inverter will perform restart and detection several times until the overloading problem is solved. Tap Clear Overload History to reset the restart time interval after the power of the loads connected to the BACK-UP ports meets the requirements. The inverter will restart immediately

9.6 Setting Advanced Parameters

9.6.1 Setting AFCI

Reasons to occur electric arcs:

- Damaged connectors in the PV or battery system.
- Wrong connected or broken cables.
- Aging connectors and cables.

Methods to detect electric arcs:

- The inverter has an integrated AFCI function satisfies IEC63027.

- When the inverter detects an electric arc, users can find the time of the fault and the detailed phenomenon through the app.
- The inverter will shutdown for protection until the AFCI alarms are cleared. After clearing the alarms, the inverter can automatically reconnect to the grid.
 - Automatic reconnection: The alarm can be cleared automatically in 5 minutes if the inverter triggers a fault for less than 5 times within 24 hours.
 - Manual reconnection: The inverter will shutdown for protection after the 5th electric arc fault within 24 hours. The inverter cannot work normally until the fault is solved.

AFCI is disabled by default, enable it through SolarGo app if needed.

Model	Label	Description
GW15K-ET	F-I-AFPE-1-2/2-2	F: Full coverage I: Integrated AFPE: Detection and interruption capability provided 1: 1 monitored string per input port 2/2: 2/2 input ports per channel 2: 2 monitored channels
GW20K-ET		
GW20K-ET	F-I-AFPE-1-2/4-2	F: Full coverage I: Integrated AFPE: Detection and interruption capability provided 1: 1 monitored string per input port 2/4: 2/4 input ports per channel 2: 2 monitored channels
GW29.9K-ET		
GW30K-ET		

Step 1 Tap **Home > Settings > Advanced Settings > AFCI Test** to set the parameters.

Step 2 Set the parameters based on actual needs. Tap '✓' or Save to save the settings. The parameters are set successfully.

Parameters	Description
AFCI Test	Enable or disable AFCI accordingly.
AFCI Test Status	The test status, like Not Self-checking, self-check succeeded, etc.
Clear AFCI Alarm	Clear ARC Faulty alarm records.
Self-check	Tap to check whether the AFCI function works normally.

9.6. 2 Setting PV Connect Mode

Step 1 Tap **Home > Settings > Advanced Settings > PV Connect Mode** to set the parameters.

Step 2 Select the PV Connect Mode based on actual needs.

Parameters	Description
Stand-alone Connect	The PV strings are connected to the MPPT terminals one by one.
Partial Parallel Connect	The PV strings are connected to the inverter in both standalone and parallel connection. For example, one PV string connect to MPPT1 ad MPPT2, another PV string connect to MPPT3.
Parallel Connect	The external PV string is connected to multi MPPT terminals of the inverter.

9.6.3 Setting Power Limit Parameters

Step 1 Tap **Home > Settings > Advanced Settings > Power Limit** to set the parameters.

Step 2 Enable or disable the power limit function based on actual needs.

Step 3 Enter the parameters and tap \checkmark . The parameters are set successfully.

No.	Parameters	Description
1	Power Limit	Enable Power Limit when power limiting is required by local grid standards and requirements.
2	Export Power (W)	Set the value based on the actual maximum power feed into the utility grid.
3	External CT Ratio	Set the ratio of the primary current to the secondary current of the external CT.

9.6.4 Setting the Battery Parameters

Step 1 Tap **Home > Settings > Advanced Settings > Battery Function** to set the parameters.

Step 2 Enter the parameters and tap \checkmark . The parameters are set successfully.

No.	Parameters	Description
1	SOC Protection	Start battery protection when the battery capacity is lower than the Depth of Discharge.
2	Depth Of Discharge (On-Grid)	Indicates the depth of discharge of the battery when the inverter is on-grid or off-grid.
3	Depth Of Discharge	

	(Off-grid)	
4	Backup SOC Holding	The battery will be charged to preset SOC protection value by utility grid or PV when the system is running on-grid. So that the battery SOC is sufficient to maintain normal working when the system is off-grid.
5	Immediate Charging	Enable to charge the battery by the grid immediately. It will only take effect once. Enable or Disable based on actual needs.
6	SOC For Stopping Charging	Stop charging the battery once the battery SOC reaches SOC For Stopping Charging .
7	Immediate Charging Power	Indicates the percentage of the charging power to the inverter rated power when enabling Immediate Charging . For example, setting the Immediate Charging Power of a 10kW inverter to 60 means the charging power of the inverter is $10kW \times 60\% = 6kW$. <ul style="list-style-type: none"> ● Start: Tap to start Immediate Charging. ● Stop: Tap to stop Immediate Charging.

9.7 Setting Load Control

Step 1 Tap **Home** > **Settings** > **Load Control** to set the parameters.

Step 2 Enter the parameters and tap ✓. The parameters are set successfully.

Dry Contact Mode: when the switch is ON, the loads will be powered; when the switch is OFF, the power will be cut off. Turn the switch on or off based on actual needs.

Time Mode: set the time to enable the load, and the load will be powered automatically within the setting time period. Select standard mode or intelligent mode.

No.	Parameters	Description
1	Standard	The loads will be powered within the setting time period.
2	Intelligent	Once the excess energy of the photovoltaic exceeds the load nominal power within the time period, the loads will be powered.
3	Start Time	The time mode will be on between the Start Time and End Time.
4	End Time	
5	Repeat	The repeat days.
6	Load Consumption Time	The shortest load working time after the loads been powered. The time is set to prevent the loads be turned on and off frequently when the PV power fluctuates greatly. Only for Intelligent mode.

7	Load Rated Power	The loads will be powered when the excess energy of the photovoltaic exceeds the nominal power of load. Only for Intelligent mode.
---	------------------	--

SOC mode: the inverter has an integrated relay controlling port, which can control the loads off or on. In off-grid mode, the load connected to the port will not be powered if the BACKUP overload is detected or the battery SOC value is lower than the Off-grid battery protection value.

9.8 Setting Safety Parameters

9.8.1 Setting the Basic Safety Parameters

NOTICE

The grid standards of some countries/regions require that inverters shall set functions to meet local requirements.

Step 1 Tap **Home > Settings > Advanced Settings**, to set the parameters.

No.	Parameters	Description
1	DRED/Remote Shutdown/RCR	Enable DRED/Remote Shutdown/RCR before connecting the third party DRED, remote shutdown, or RCR device to comply with local laws and regulations.
2	Three-phase Unbalanced Output	Enable Three-phase Unbalanced Output when the utility grid company adopts phase separate billing.
3	Backup N and PE Relay Switch	To comply with local laws and regulations, ensure that the relay inside the back-up port remains closed and the N and PE wires are connected when the inverter is working off-grid.
4	AutoTest	Enable AUTO TEST to set auto test for grid tying in compliance with local grid standards and requirements.

9.8.2 Setting Customized Safety Parameters

NOTICE

Set the custom safety parameters in compliance with local requirements. Do not change the parameters without the prior consent of the grid company.

9.8.2.1 Setting the Active Power Mode

Setting the P(F) Curve

Step 1 Tap **Home** > **Settings** > **Advanced Settings** > **Safety Parameter Settings** > **Active Power Mode** to set the parameters.

Step 2 Set the parameters based on actual needs.

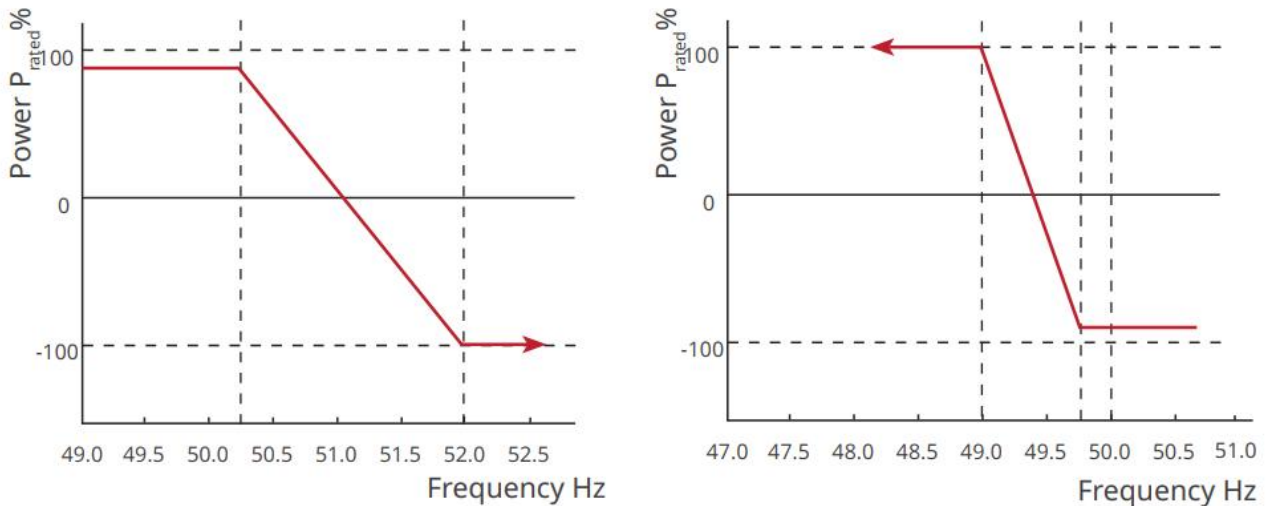

Setting the P(U) Curve

Step 1 Tap **Home** > **Settings** > **Advanced Settings** > **Safety Parameter Settings** > **Active Power Mode** to set the parameters.

Step 2 Enter the parameters. The inverter will adjust the active output power to the apparent power ratio in real-time according to the actual grid voltage to the rated voltage ratio.

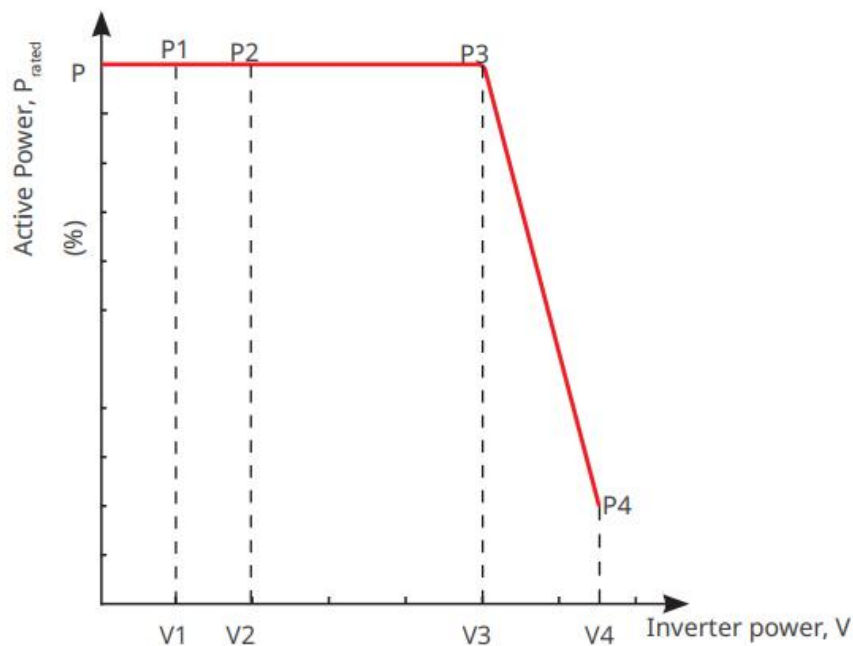

9.8.2.2 Setting the Reactive Power Mode

Setting the Fix PF

Step 1 Tap **Home > Settings > Advanced Settings > Safety Parameter Settings > Reactive Power Mode** to set the parameters.

Step 2 Set the parameter based on actual needs. The power factor remains fixed during the inverter working process.

No.	Parameters	Description
1	Fix PF	Enable Fix PF when it is required by local grid standards and requirements.
2	Under-excited	Set the power factor as lagging or leading based on actual needs and local grid standards and requirements.
3	Over-excited	
4	Power Factor	Set the power factor based on actual needs. Range: 0~-0.8, or +0.8~+1.

Setting the Fix Q

Step 1 Tap **Home > Settings > Advanced Settings > Safety Parameter Settings > Reactive Power Mode** to set the parameters.

Step 2 Set the parameter based on actual needs. The output reactive power remains fixed during the inverter working process.

No.	Parameters	Description
1	Fix Q	Enable Fix Q when it is required by local grid standards and requirements.
2	Under-excited	Set the reactive power as inductive or capacitive reactive power based on actual needs and local grid standards and requirements.
3	Over-excited	
4	Power Factor	The percentage of reactive output power to apparent power.

Setting the Q(U) Curve

Step 1 Tap **Home > Settings > Advanced Settings > Safety Parameter Settings > Reactive Power Mode** to set the parameters.

Step 2 Enter the parameters. The inverter will adjust the reactive power to the apparent power ratio in real-time according to the actual grid voltage to the rated voltage ratio.

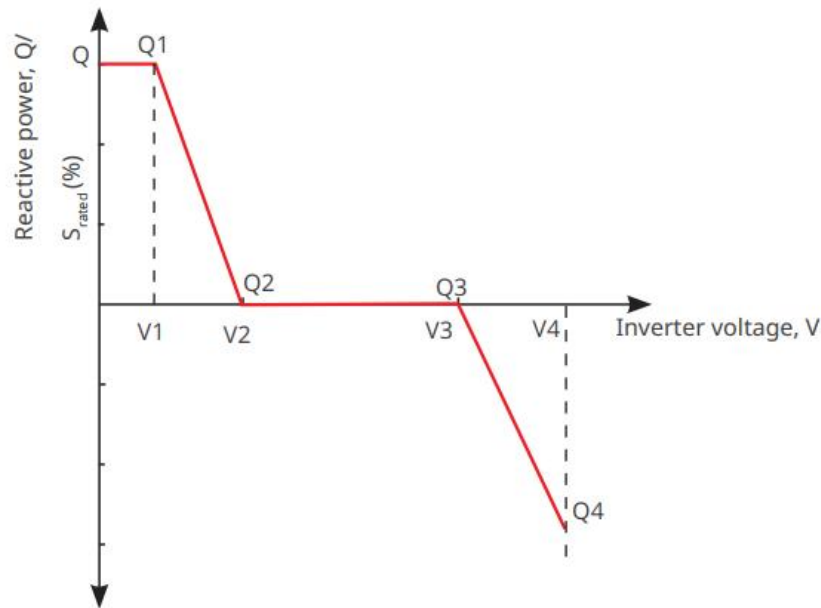

Setting the Cosφ Curve

Step 1 Tap **Home** > **Settings** > **Advanced Settings** > **Safety Parameter Settings** > **Reactive Power Mode** to set the parameters.

Step 2 Enter the parameters. The inverter will adjust the active output power to the apparent power ratio in real-time according to the actual grid voltage to the rated voltage ratio.

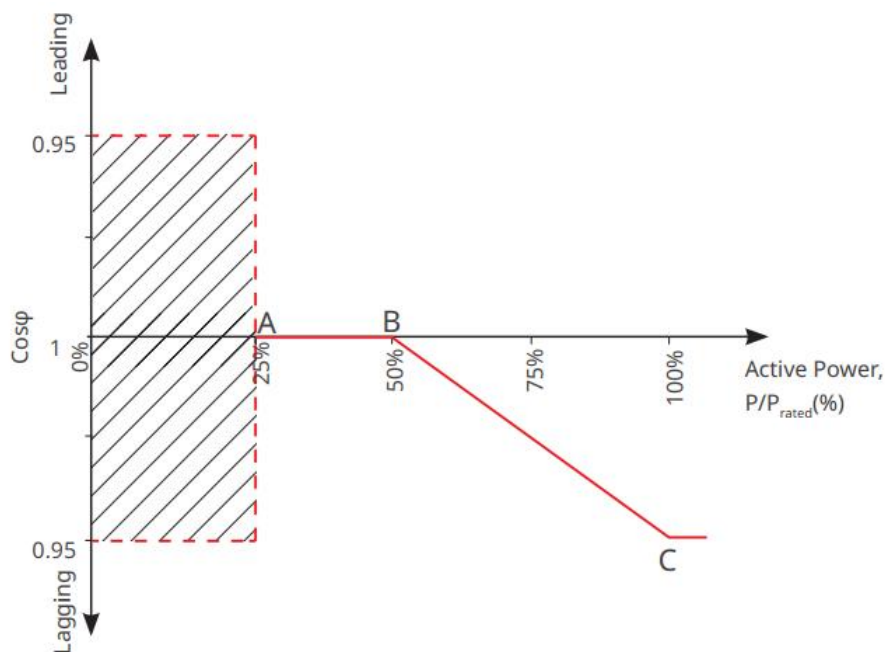

9.8.2.3 Setting Protection Parameters

Step 1 Tap **Home** > **Settings** > **Advanced Settings** > **Safety Parameters** > **Protection Parameters** to set the parameters.

Step 2 Set the parameters based on actual needs.

No.	Parameters	Description
-----	------------	-------------

Voltage Protection Parameters		
1	OV Stage n Trip Value	Set the grid overvoltage protection threshold value, n = 1, 2, 3.
2	OV Stage n Trip Time	Set the grid overvoltage protection tripping time, n = 1, 2, 3.
3	UV Stage n Trip Value	Set the grid undervoltage protection threshold value, n= 1, 2, 3.
4	UV Stage n Trip Time	Set the grid undervoltage protection tripping time, n = 1, 2, 3.
5	Grid 10min Overvoltage	Set the 10min overvoltage protection threshold value.
Frequency Protection Parameters		
6	OF Stage n Trip Value	Set the grid overfrequency protection threshold value, n = 1, 2.
7	OF Stage n Trip Time	Set the grid overfrequency protection tripping time, n = 1, 2.
8	UF Stage n Trip Value	Set the grid underfrequency protection threshold value, n = 1, 2.
9	UF Stage n Trip Time	Set the grid underfrequency protection tripping time, n = 1, 2.

9.8.2.4 Setting Connection Parameters

Step 1 Tap **Home** > **Settings** > **Advanced Settings** > **Safety Parameters** > **Connection Parameters** to set the parameters.

Step 2 Set the parameters based on actual needs.

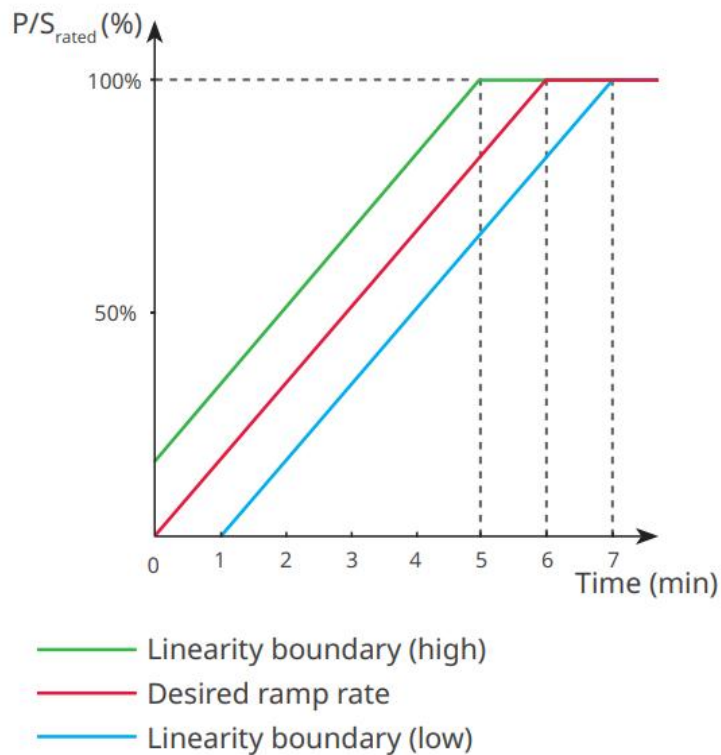

9.8.2.5 Setting Voltage Ride Through Parameters

Step 1 Tap **Home** > **Settings** > **Advanced Settings** > **Safety Parameters** > **Voltage Ride Through** to set the parameters.

Step 2 Set the parameters based on actual needs.

No.	Parameters	Description
LVRT		
1	Ride Through Voltage Start Point	The inverter will not be disconnected from the utility grid immediately when the grid voltage is between Ride Through Voltage Start Point and Ride Through Voltage End Point.
2	Ride Through Voltage End Point	
3	Ride Through Time Start Point	Indicates the longest duration the inverter can remain connected to the grid when the grid voltage is at the Ride Through Voltage Start Point.
4	Ride Through Time End Point	Indicates the longest duration the inverter can remain connected to the grid when the grid voltage is at the Ride Through Voltage End Point.
5	Ride Through Trip Threshold	LVRT is allowed when the grid voltage is lower than Ride Through Trip Threshold

HVRT		
6	Ride Through Voltage Start Point	The inverter will not be disconnected from the utility grid immediately when the grid voltage is between Ride Through Voltage Start Point and Ride Through Voltage End Point.
7	Ride Through Voltage End Point	
8	Ride Through Time Start Point	Indicates the longest duration the inverter can remain connected to the grid when the grid voltage is at the Ride Through Voltage Start Point.
9	Ride Through Time End Point	Indicates the longest duration the inverter can remain connected to the grid when the grid voltage is at the Ride Through Voltage End Point.
10	Ride Through Trip Threshold	HVRT is allowed when the grid voltage is higher than Ride Through Trip Threshold

10 Monitoring Power Plant

10.1 SEMS Portal Overview

SEMS Portal App is a monitoring platform. Commonly used functions are as follows:

1. Manage the organization or User information;
2. Add and monitor the power plant information;
3. Equipment maintenance.

Login Page of SEMS Portal App

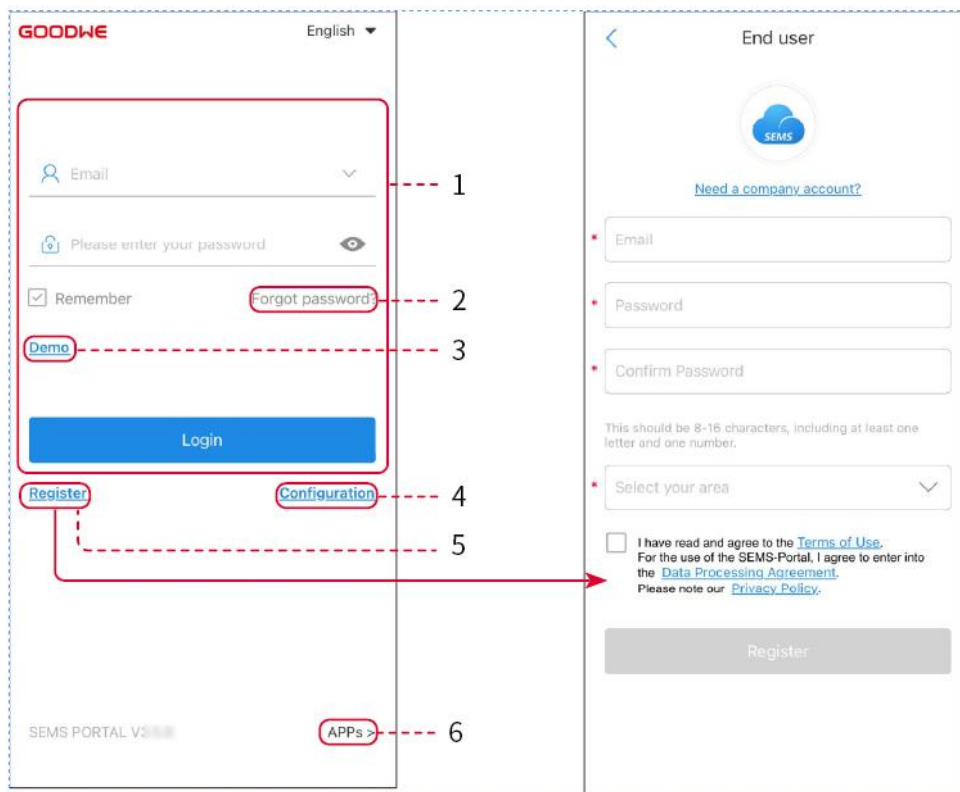







No.	Name	Description
1	Login Area	Enter the user name, password to login to the app.
2	Forget Password	Tap to reset the password by verifying the account.
3	Demo	Tap to enter the sample plant page. The sample page only displays contents with Visitor account, which is for reference only.
4	Configuration	Configure WiFi parameters to establish communication between the inverter and the server and realize remote monitoring and managing.

5	Register	Tap to register an end-user account. Contact the manufacturer or the company as prompted if you need a company account.
6	Demo	Tap to enter the sample plant page. The sample page only displays contents with Visitor account, which is for reference only.

Home Page of SEMS Portal App



No.	Name	Description
1		Create a new power plant.
2	Plant status	The summary of the plants working information under the account.
3	Find the plant	Find the plant by entering the plant name, device SN, Email address, or map.
4	Generation statistics	The working information of a single plant. Tap the plant name to check the detailed information of the plant, such as plant name, location, power, capacity, generation today, total generation, etc.

5	 Plants	Plant monitoring page.
6	 Alarms	Check all alarms, happening alarms, and recovered alarms.
7	 WiFi	Complete WiFi configurations when a Wi-Fi Kit dongle is used.
8	 Message	Message Set and check system messages.
9	 Discovery	Discovery To Edit the account, create My QR Code, set Income Settings , etc.

10.2 Managing the Plant or Devices

10.2.1 Creating Power Plants

Step 1 Enter the **Create Plant** page.

Step 2 Read the instructions and fill in the requested plant information based on actual situation. (* refers to the mandatory items)

Step 3 Follow the prompts to add devices and create the plant.

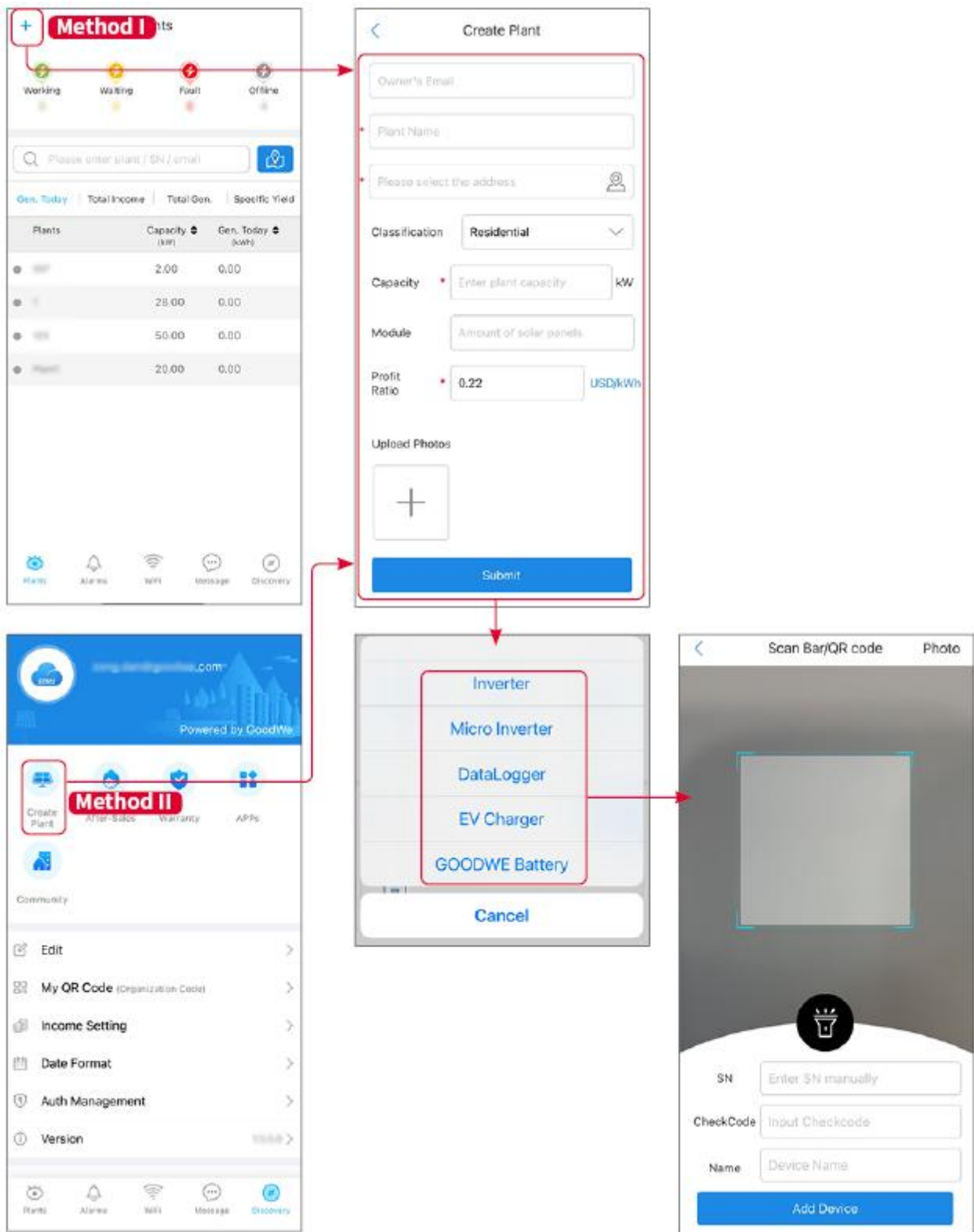

10.2.2 Managing the Plant

Step 1 Enter the plant monitoring page to delete or modify plant information based on actual needs.

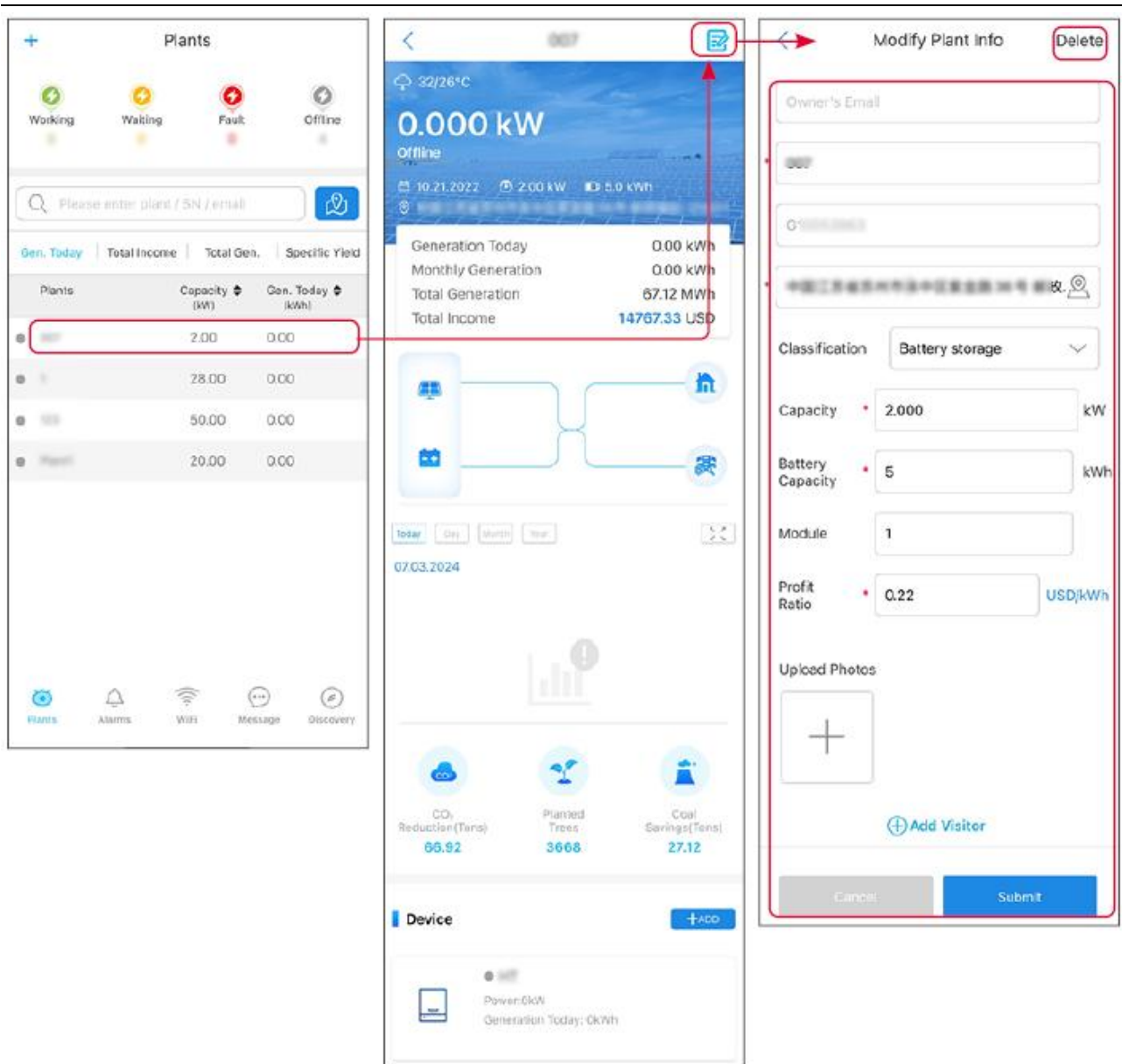

10.2.3 Managing the Devices

Step 1 Select the power plant and enter the detailed information page.

Step 2 Add, delete, or replace the devices based on actual needs.

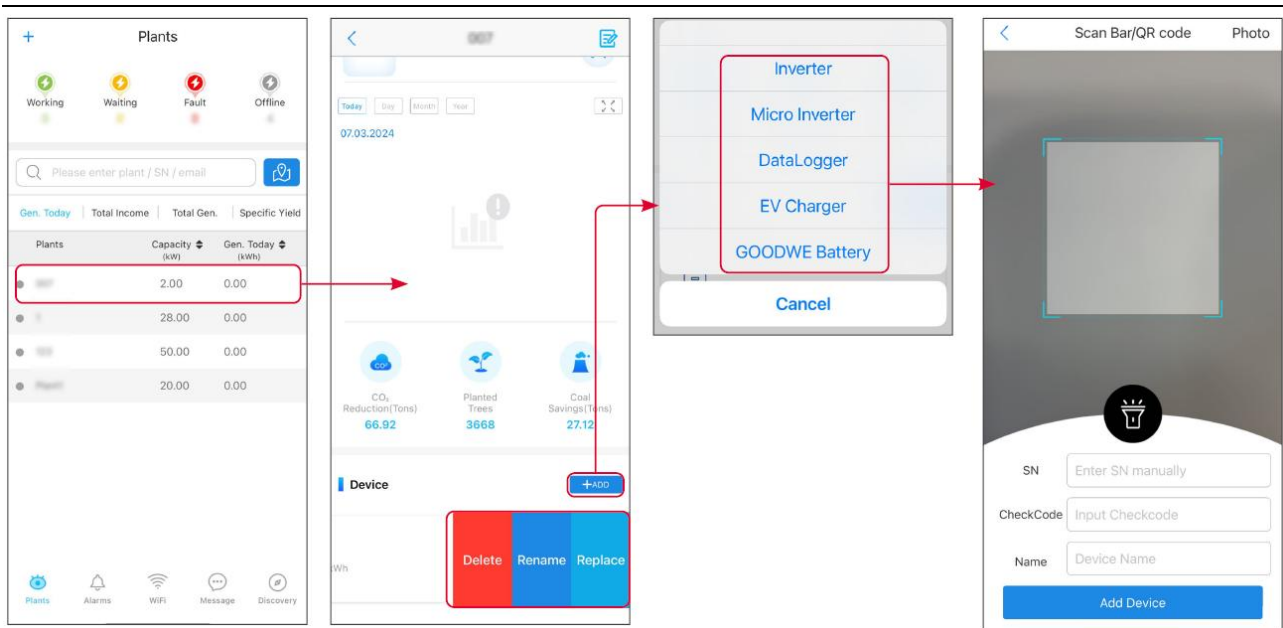

10.3 Monitoring the Plant

10.3.1 Checking the Plant Information

Log in the SEMS Portal app with the account and password. The overall working situation of all power plants under this account will be displayed.

The interface varies depending on the devices.

Step 1 (optional) Search the plant name, inverter SN, or Email to find out the plant quickly.

Or tap the map icon to search the plant.

Step 2 Tap the plant name in the plant list or the plant icon in the map to check detailed information about the plant.

Step 3 Check the plant information, power generation situation, device information, faults, etc.

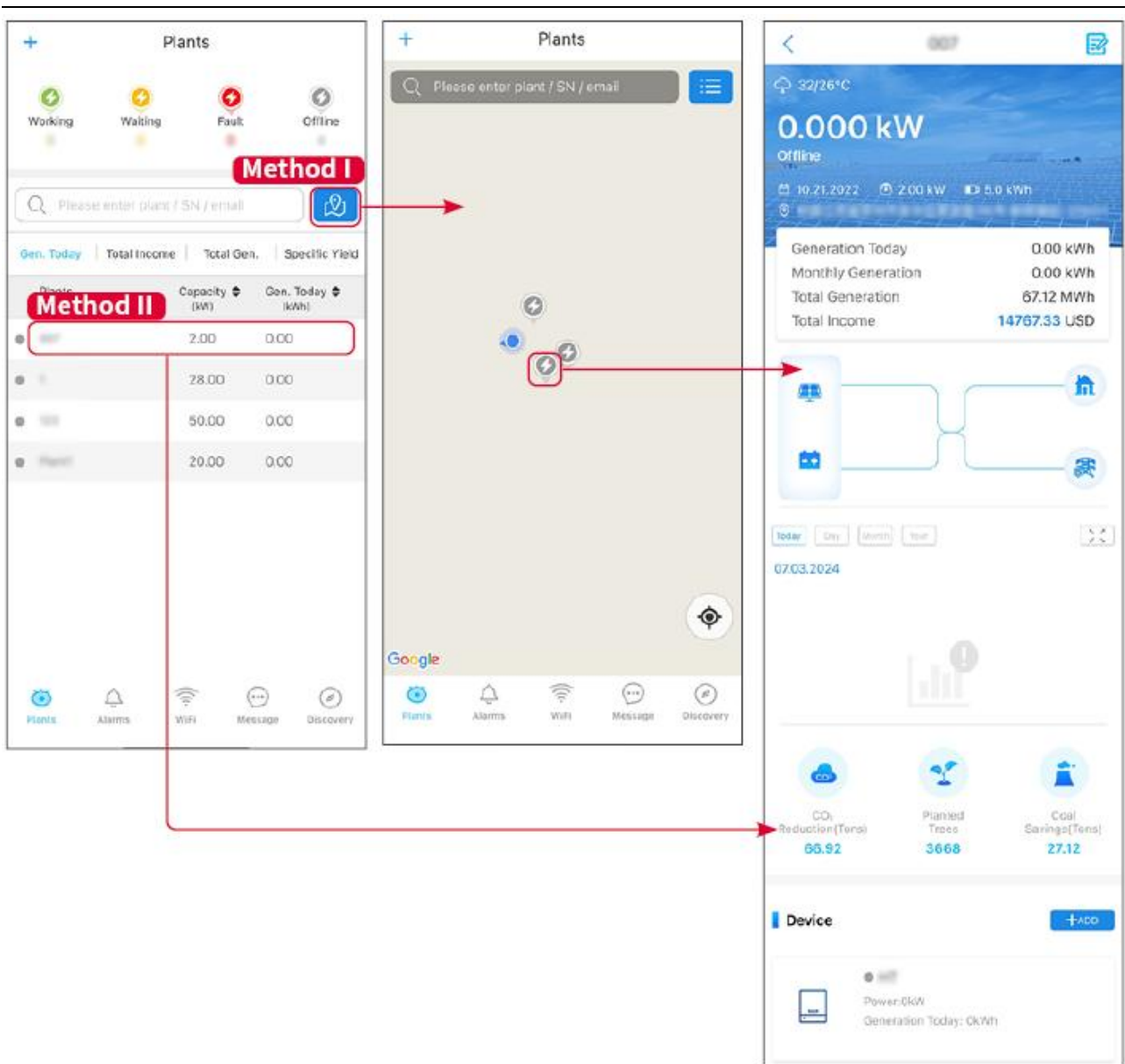

10.3.2 Checking Alarms

Step 1 Tap Alarm tab and enter the Alarm Details page.

Step 2 (optional) Enter the plant name, inverter SN, or owner's Email address in the search bar to find out the plant which is alarming.

Step 3 Tap the alarm name to check the alarm details.

Alarms

1
All
4,388(71)

1
Happening
8(7%)

1
Recovered
4,380(93)

Plant	Alarm	Occurrence
WAARE SOLAR	Utility Loss	07.03.2024 07:23
WAARE SOLAR	Vac Fail	07.03.2024 07:23
Ray Perimeter	Vac Fail	07.03.2024 04:22
Chandrabhawan	Vac Fail	07.03.2024 07:52
	Fac Fail	07.03.2024 10:22
	Vac Fail	07.03.2024 10:22
	Utility Loss	07.03.2024 10:22
g@waarebio	Vac Fail	07.03.2024 07:52
g@waarebio	Utility Loss	07.03.2024 07:52
g@waarebio	Fac Fail	07.03.2024 07:52
Thapan	Vac Fail	07.03.2024 07:52

Plants

Alarms

WiFi

Message

Discovery

<
Alarm Details
☆

WAARE SOLAR
🏠

Owner: --

Device: INVERTER

SN: [REDACTED]

Alarm: Utility Loss

Status: Happening

Occurrence: 07.03.2024 07:23:01

Recovery: --

Possible Reasons

1. Grid power fails.
2. AC connection is not good.
3. AC breaker fails
4. Grid is not connected.

Troubleshooting

1. Make sure grid power is available.
2. Check (use multimeter) if AC side has voltage.
3. Check if breaker is good.
4. Check AC side connection is right or not (Make sure L/N cable are connected in the right place).
5. Make sure grid is connected and AC breaker turned ON.
6. If all is well, please try to turn off AC breaker and turn on again after 5 mins.

11 Maintenance

11.1 Power OFF the System

! DANGER

- Power off the equipment before operations and maintenance. Otherwise, the equipment may be damaged or electric shocks may occur.
- Delayed discharge. Wait until the components are discharged after power off.
- Push the air switch to restart the battery.
- Strictly follow the power off requirements to avoid damaging the system

NOTICE

- Install the circuit breaker between the inverter and the battery or between the two batteries in compliance with local laws and regulations.
- To ensure effective protection, the cover of the battery system switch should remain closed. The cover can be closed automatically after being opened. Fasten the cover with screws if the switch is not to be used for a long-term period.

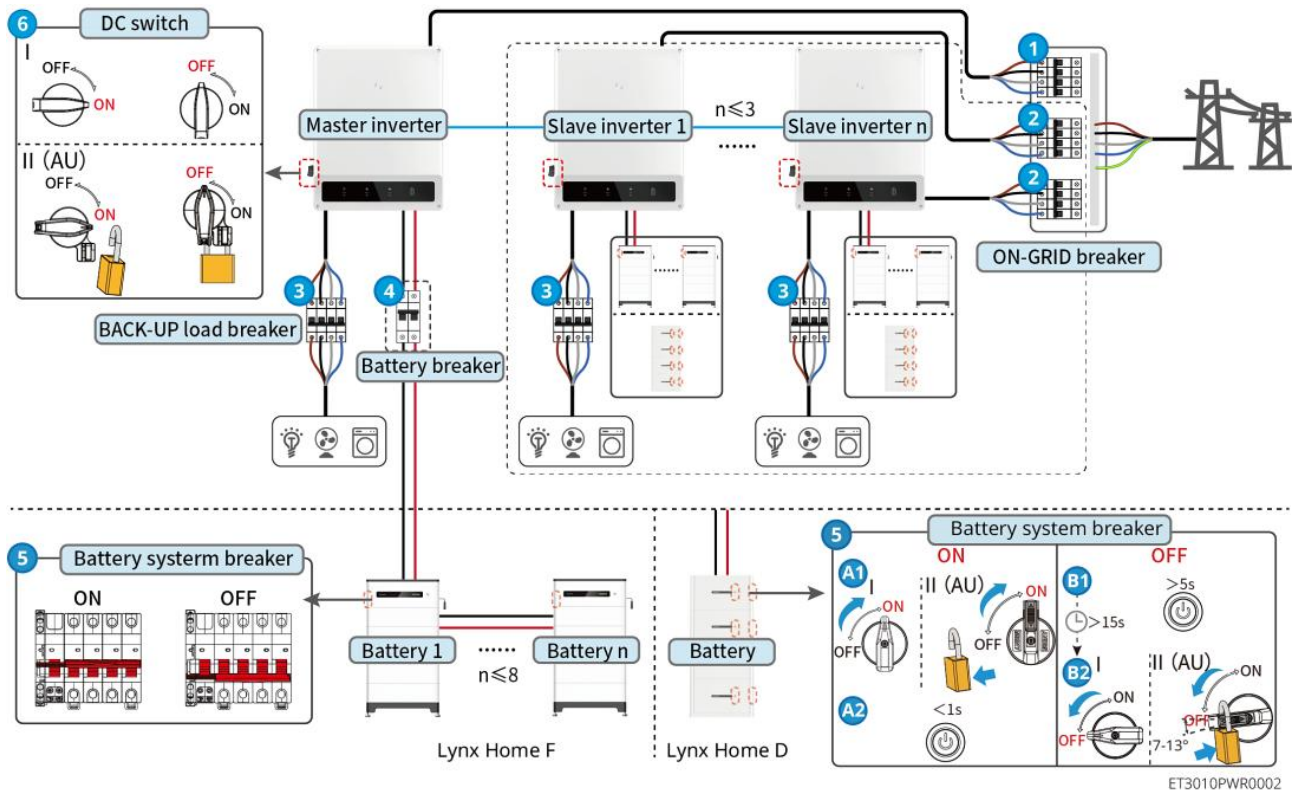

ET3010PWR0002

Power ON/OFF: 1 → 2 → 3 → 4 → 5 → 6

④: Optional in compliance with local laws and regulations.

11.2 Removing the Equipment



- Make sure that the equipment is powered off.
- Wear proper personal protective equipment during operations.
- Use the PV tool and battery tool included in the package to remove the PV connector and battery connector.

Step 1 Power off the system.

Step 2 Tag different cable types in the system.

Step 3 Disconnect the inverter, battery, and BACK-UP loads.

Step 4 Remove the inverter from the mounting plate.

Step 3 Remove the smart meter and smart dongle.

Step 4 Store the equipment properly. If the equipment needs to be used later, ensure that the storage conditions meet the requirements.

11.3 Disposing of the Equipment

If the equipment cannot work anymore, dispose of it according to the local disposal requirements for electrical equipment waste. The equipment cannot be disposed of together with household waste.

11.4 Routine Maintenance



- Contact after-sales service for help if you find any problems that may influence the battery or the hybrid inverter. Disassemble without permission is strictly forbidden.
- Contact after-sales service for help if the copper conductor is exposed. Do not touch or disassemble privately because high voltage danger exists.
- In case of other emergencies, contact the after-sales service as soon as possible. Operate following the instructions or wait for the after-sales service personnel.

Maintaining Item	Maintaining method	Maintaining period	Maintaining purpose
System clean	1. Check the heat sink, air intake, and air outlet for foreign matter or dust. 2. Check whether the	Once half a year	Avoid heat dissipation faults.

	installation space meets requirements and whether there is any debris around the device.		
System installation	<ol style="list-style-type: none"> 1. Check whether the equipment are installed securely and whether the screws are installed tightly. 2. Check whether the equipment is damaged or deformed. 	Once 6-12 months	Ensure that the equipment is installed securely.
Electrical connection	Check whether the cables are securely connected. Check whether the cables are broken or whether there is any exposed copper core.	Once 6-12 months	Verify the reliability of electrical connections.
Sealing	Check whether all the terminals and ports are properly sealed. Reseal the cable hole if it is not sealed or too big.	Once a year	Ensure that the equipment is sealed properly.

11.5 Troubleshooting

Perform troubleshooting according to the following methods. Contact the after-sales service if these methods do not work.

Collect the information below before contacting the after-sales service, so that the problems can be solved quickly.



1. Product information like serial number, software version, installation date, fault time, fault frequency, etc.
2. Installation environment, including weather conditions, whether the PV modules are sheltered or shadowed, etc. It is recommended to provide some photos and videos to assist in analyzing the problem.
3. Utility grid situation.

11.5.1 System Communication Troubleshooting

No.	Cause	Solutions
1	Cannot find WiFi signals	<ol style="list-style-type: none"> 1. Make sure that the Smart Dongle on the inverter is powered on and the blue indicator is flashing or steady on. 2. Make sure that the Smart Dongle is within its

		<p>communication range.</p> <ol style="list-style-type: none"> 3. Refresh the device list in the app. 4. Restart the inverter
2	Unable to connect to the WiFi signal	<ol style="list-style-type: none"> 1. Ensure successful pairing of Bluetooth. 2. Make sure no other smart device is connected to the inverter signal. 3. Restart the inverter and reconnect to the inverter signal.
3	Cannot find router SSID	<ol style="list-style-type: none"> 1. Put the router nearer to the Smart Dongle. Or add a WiFi relay device to enhance the WiFi signal. 2. Reduce the number of devices connected to router.
4	After completing all configurations, the Smart Dongle fails connecting to the router.	<ol style="list-style-type: none"> 1. Restart the inverter 2. Check if the SSID, encryption method and password on WiFi configuration page are the same with that of Router. 3. Restart the router. 4. Put the router nearer to the Smart Dongle. Or add a WiFi relay device to enhance the WiFi signal.
5	After completing all configurations, the Smart Dongle fails connecting to the router.	Restart the router and the inverter.
6	Cannot log in to 10.10.100.253	<ol style="list-style-type: none"> 1. Switch browsers like Google Chrome, Firefox, IE, Safari. 2. Restart the inverter and reconnect the WiFi.
7	Cannot find router SSID on searching page	<ol style="list-style-type: none"> 1. Put the router nearer to the inverter. Or add some WiFi relay devices. 2. Check whether the router channel number is more than 13. 3. If yes, modify it into a lower number at router configuration page.

No.	Fault	Solutions
1	 Indicator double blinks	<ol style="list-style-type: none"> 1. Make sure that the router is powered on. 2. When communicating via LAN, make sure that both LAN cable connection and LAN configuration are proper. Enable or disable DHCP based on actual needs. 3. When communicating via WiFi, make sure that the wireless network connection is OK and the

		wireless signal strength meets the requirements. Enable or disable DHCP based on actual needs.
2	 Indicator quadruple blinks	<ol style="list-style-type: none"> 1. Make sure that the smart dongle is connected to the router via WiFi or LAN properly, and the router can access the Internet. 2. If the problem persists, contact the after sales service.
3	 Indicator off	Make sure that the inverter is powered on. If the problem persists, contact the after sales service.
4	 Indicator off	Make sure that the inverter is powered on.

11.5.2 Inverter Troubleshooting

Single inverter

No.	Fault	Cause	Solutions
1	Utility Loss	<ol style="list-style-type: none"> 1. Utility grid power fails. 2. The AC cable is disconnected, or the AC breaker is off. 	<ol style="list-style-type: none"> 1. The alarm is automatically cleared after the grid power supply is restored. 2. Check whether the AC cable is connected and the AC breaker is on.
2	Grid Overvoltage	The grid voltage exceeds the permissible range, or the duration of high voltage exceeds the requirement of HVRT.	<ol style="list-style-type: none"> 1. If the problem occurs occasionally, the utility grid may be abnormal temporarily. The inverter will recover automatically after detecting that the utility grid is normal. 2. If the problem occurs frequently, check whether the grid voltage is within the permissible range. <ul style="list-style-type: none"> ● Contact the local power company if the grid voltage exceeds the permissible range. ● Modify the overvoltage protection threshold, HVRT or disable the overvoltage protection function after obtaining the consent of the local power company if the grid frequency is within the permissible range. 3. Check whether the AC breaker and the output cables are connected securely and correctly if the problem persists.
3	Grid Rapid Overvoltage	The grid voltage is abnormal or ultrahigh.	<ol style="list-style-type: none"> 1. If the problem occurs occasionally, the utility grid may be abnormal temporarily. The inverter will recover automatically after detecting that the utility grid is normal.

			<ol style="list-style-type: none"> 2. If the problem occurs frequently, check whether the grid voltage is within the allowed range. <ul style="list-style-type: none"> ● Contact the local power company if the grid voltage exceeds the permissible range. ● Modify the grid overvoltage rapid protection threshold after obtaining the consent of the local power company if the grid voltage is within the permissible range.
4	Grid Undervoltage	The grid voltage is lower than the permissible range, or the duration of low voltage exceeds the requirement of LVRT.	<ol style="list-style-type: none"> 1. If the problem occurs occasionally, the utility grid may be abnormal temporarily. The inverter will recover automatically after detecting that the utility grid is normal. 2. If the problem occurs frequently, check whether the grid voltage is within the permissible range. <ul style="list-style-type: none"> ● Contact the local power company if the grid voltage exceeds the permissible range. ● Modify the undervoltage protection threshold, LVRT or disable the undervoltage protection function after obtaining the consent of the local power company if the grid frequency is within the permissible range. 3. Check whether the AC breaker and the output cables are connected securely and correctly if the problem persists.
5	Grid 10min Overvoltage	The moving average of grid voltage in 10min exceeds the range of safety requirements.	<ol style="list-style-type: none"> 1. If the problem occurs occasionally, the utility grid may be abnormal temporarily. The inverter will recover automatically after detecting that the utility grid is normal. 2. If the problem occurs frequently, check whether the grid voltage is within the allowed range. <ul style="list-style-type: none"> ● Contact the local power company if the grid voltage exceeds the permissible range. ● Modify the grid overvoltage rapid protection threshold after obtaining the consent of the local power company if the grid voltage is within the permissible range.
6	Grid Overfrequency	Utility grid exception. The actual grid frequency exceeds the	<ol style="list-style-type: none"> 1. If the problem occurs occasionally, the utility grid may be abnormal temporarily. The inverter will recover automatically after detecting that the utility grid is normal.

		requirement of the local grid standard.	<ol style="list-style-type: none"> If the problem occurs frequently, check whether the grid frequency is within the permissible range. <ul style="list-style-type: none"> Contact the local power company if the grid frequency exceeds the permissible range. Modify the overfrequency protection threshold or disable the overfrequency protection function after obtaining the consent of the local power company if the grid frequency is within the permissible range.
7	Grid Underfrequency	Utility grid exception. The actual grid frequency is lower than the requirement of the local grid standard.	<ol style="list-style-type: none"> If the problem occurs occasionally, the utility grid may be abnormal temporarily. The inverter will recover automatically after detecting that the utility grid is normal. If the problem occurs frequently, check whether the grid frequency is within the permissible range. <ul style="list-style-type: none"> Contact the local power company if the grid frequency exceeds the permissible range. Modify the underfrequency protection threshold or disable the underfrequency protection function after obtaining the consent of the local power company if the grid frequency is within the permissible range. Or close Grid Underfrequency function.
8	Grid Frequency Instability	Utility grid exception. The actual grid frequency change rate does not meet the requirement of the local grid standard.	<ol style="list-style-type: none"> If the problem occurs occasionally, the utility grid may be abnormal temporarily. The inverter will recover automatically after detecting that the utility grid is normal. If the problem occurs frequently, check whether the grid frequency is within the permissible range. <ul style="list-style-type: none"> Contact the local power company if the grid frequency exceeds the permissible range. Contact the dealer or the after-sales service if the grid frequency is within the permissible range.
9	Anti-islanding	The utility grid is disconnected. The utility grid is disconnected according to the safety regulations, but the grid voltage	<ol style="list-style-type: none"> Check whether the utility grid is disconnected. Contact the dealer or the after-sales service.

		is maintained due to the loads.	
10	LVRT Undervoltage	Utility grid exception. The duration of the utility grid exception exceeds the set time of LVRT.	<ol style="list-style-type: none"> 1. If the problem occurs occasionally, the utility grid may be abnormal temporarily. The inverter will recover automatically after detecting that the utility grid is normal. 2. If the problem occurs frequently, check whether the grid frequency is within the permissible range. If not, contact the local power company. If yes, contact the dealer or the after-sales service.
11	HVRT Overvoltage	Utility grid exception. The duration of utility grid exception exceeds the set time of HVRT.	
12	Abnormal GFCI 30mA	The input insulation impedance becomes low when the inverter is working.	<ol style="list-style-type: none"> 1. If the problem occurs occasionally, it may be caused by a cable exception. The inverter will recover automatically after the problem is solved. 2. Check whether the impedance between the PV string and PE is too low if the problem occurs frequently or persists.
13	Abnormal GFCI 60mA		
14	Abnormal GFCI 150mA		
15	Abnormal GFCI		
16	Large DC of AC current L1	The DC component of the output current exceeds the safety range or default range.	<ol style="list-style-type: none"> 1. If the problem is caused by an external fault like a utility grid exception or frequency exception, the inverter will recover automatically after solving the problem. 2. If the problem occurs frequently and the PV station cannot work properly, contact the dealer or the after-sales service.
17	Large DC of AC current L2		
18	Low Insulation Res.	The PV string is short-circuited to PE. The PV system is in a moist environment and the cable is not well insulated to the ground.	<ol style="list-style-type: none"> 1. Check whether the resistance of the PV string to PE exceeds 50kΩ. If no, check the short circuit point. 2. Check whether the PE cable is connected correctly.
19	Anti Reverse power Failure	Abnormal fluctuation of load	<ol style="list-style-type: none"> 1. If the exception is caused by an external fault, the inverter will recover automatically after solving the problem. 2. If the problem occurs frequently and the PV station cannot work properly, contact the dealer or the after-sales service.
20	Internal Comm Loss	<ol style="list-style-type: none"> 1. Frame format error 2. Parity checking error 	Disconnect the AC output switch and DC input switch, then connect them 5 minutes later. Contact the dealer or the after-sales service if the problem persists.

		<ol style="list-style-type: none"> 3. Can bus offline 4. Hardware CRC error 5. Send (receive) control bit is receive (send). 6. Transmit to the unit that is not allowed. 	
21	AC HCT Check abnormal	The sampling of the AC HCT is abnormal.	Disconnect the AC output switch and DC input switch, then connect them 5 minutes later. Contact the dealer or the after-sales service if the problem persists.
22	GFCI HCT Check abnormal	The sampling of the GFCI HCT is abnormal.	Disconnect the AC output switch and DC input switch, then connect them 5 minutes later. Contact the dealer or the after-sales service if the problem persists.
23	Relay Chk Fail	<ol style="list-style-type: none"> 1. Relay Fault 2. The control circuit is abnormal. 3. The AC cable is connected improperly, like a virtual connection or short circuit. 	Disconnect the AC output switch and DC input switch, then connect them 5 minutes later. Contact the dealer or the after-sales service if the problem persists.
24	Flash Fault	The internal Flash storage is abnormal.	Disconnect the AC output switch and DC input switch, then connect them 5 minutes later. Contact the dealer or the after-sales service if the problem persists.
25	DC Arc Fault	<ol style="list-style-type: none"> 1. The DC terminal is not firmly connected. 2. The DC cable is broken. 	Read the Quick Installation Guide and check whether the cables are connected properly.
26	AFCI Self-test Fault	AFCI detection is abnormal.	Disconnect the AC output switch and DC input switch, then connect them 5 minutes later. Contact the dealer or the after-sales service if the problem persists.
27	Cavity Overtemperature	<ol style="list-style-type: none"> 1. The inverter is installed in a place with poor ventilation. 2. The ambient temperature exceeds 60°C. 	<ol style="list-style-type: none"> 1. Check the ventilation and the ambient temperature at the installation point. 2. If the ventilation is poor or the ambient temperature is too high, improve the ventilation and heat dissipation. 3. Contact the dealer or after-sales service if both the ventilation and the ambient temperature

		3. A fault occurs in the internal fan of the inverter.	are normal.
28	BUS Overvoltage	1. The PV voltage is too high. 2. The sampling of the inverter BUS voltage is abnormal.	Disconnect the AC output switch and DC input switch, then connect them 5 minutes later. Contact the dealer or the after-sales service if the problem persists.
29	PV Input Overvoltage	The PV array configuration is not correct. Too many PV panels are connected in series in the PV string.	Check the serial connection of the PV array. Make sure that the open circuit voltage of the PV string is not higher than the maximum operating voltage of the inverter.
30	PV Continuous Hardware Overcurrent	1. The PV configuration is not proper. 2. The hardware is damaged.	Disconnect the AC output switch and DC input switch, then connect them 5 minutes later. Contact the dealer or the after-sales service if the problem persists.
31	PV Continuous Software Overcurrent	1. The PV configuration is not proper. 2. The hardware is damaged.	Disconnect the AC output switch and DC input switch, then connect them 5 minutes later. Contact the dealer or the after-sales service if the problem persists.
32	String1 PV String Reversed	The PV strings are connected reversely.	Check whether the PV1 and PV2 strings are connected reversely.
33	String2 PV String Reversed		

Parallel System

No.	Fault	Cause	Solutions
1	Abnormal parallel CAN communication	The parallel communication cable connection is abnormal, or an inverter in the parallel system is offline.	Check whether all the inverters are powered on and whether the parallel communication cables are firmly connected.
2	Communication indicator of the inverter and Ezlink indicator in error	Ezlink connection failed	1. Check whether the WiFi signal is normal. If it is not, check whether the router works well. 2. Check whether Ezlink obtains IP successfully via APP. Execute the following

			<p>if IP is not obtained:</p> <ol style="list-style-type: none"> Reset the communication parameters via APP Check whether the server connection is correct. Log in to the website mqtt.goodwepower.com in PC, check the analyzed IP address and obtain the connected server information.
3	Unable to log in to the parallel system interface in APP	Parallel networking failed	<ol style="list-style-type: none"> Incorrect communication cable connection or unreliable cable connection cause communication failure. Connect the smart meter and Ezlink module to the same master inverter to ensure the success rate of networking. Check whether the inverter communication indicator is normal. If it is not, please check the individual inverter according to its own troubleshooting method. If the above methods cannot solve the problem, please try to restart the inverter and get networking again.
4	Parallel IO check fail	Communication of parallel inverters in error	<ol style="list-style-type: none"> Check whether the parallel communication cable is connected correctly and firmly. If the communication cable connection is normal, it may be an internal communication failure. Please contact the dealer or After Sale Service.
5	Device offline displayed on APP	Communication failure or equipment failure	<ol style="list-style-type: none"> Check whether the quantity of parallel machines in the system is the same with the actual connected ones. If it is, get the SN of the corresponding offline inverter from the equipment list, and troubleshoot the corresponding inverter according to its user manual. Check whether the communication connection of the equipment is normal, with no loose, aging or wrong connection, etc.

11.5.3 Battery Troubleshooting

Common faults

No.	Fault	Cause	Solutions
-----	-------	-------	-----------











1	Battery system tilt	The ground is uneven or deformed.	Place the battery on a flat and hard ground.
2	Indicator light goes out during operation	Cable short circuit or internal failure of battery system.	<ol style="list-style-type: none"> 1. Check for short circuits in external cables. 2. Turn off the battery system and wait for 2 hours, then turn it on.
3	Button indicator light turns to red and flashes, and the SOC light displays battery percentage.	<ul style="list-style-type: none"> ● Communication cable fault. ● The battery model set in SolarGo App is incorrect. 	<ol style="list-style-type: none"> 1. Check if the communication cables are correct. 2. Check if the inverter is working properly. 3. Set correct battery system model through the SolarGo App.

















when the button indicator turns to red, check the SOC indicator status to find out the fault.









Lynx home F、Lynx home F PLUS+

No.	SOC indicator	Fault	Solutions
1		Battery Overvoltage	Restart the battery. If the problem persists, please contact the after-sales service.
2		Battery Undervoltage	Long press the button for 5 seconds to start the battery under charging conditions. If the problem persists, contact the after-sales service.
3		Overcurrent Charging	Restart the battery. If the problem persists, please contact the after-sales service.
4		Overcurrent Discharging	Restart the battery. If the problem persists, please contact the after-sales service.
5		Temperature Difference Exception	Power off and wait for 2 hours. If the problem persists, please contact the after-sales service.
6		High Temperature	Power off and wait for 2 hours. If the problem persists, please contact the after-sales service.
7		Low Temperature	Power off and wait for 2 hours. If the problem persists, please contact the after-sales service.
8		Inconsistent Software Version	Contact the after-sales service.







9		Precharge Fault	Restart the battery. If the problem persists, please contact the after-sales service.
10		Relay Fault	Restart the battery. If the problem persists, please contact the after-sales service.
11		Air Switch Fault	Restart the battery. If the problem persists, please contact the after-sales service.
12		Insulation Fault	Do not touch the battery and contact the after-sales service.
13		Internal Communication Fault	Power off and check the communication cables. Restart the battery. If the problem persists, contact the after-sales service.
14		SN Fault	Contact the after-sales service.
15		Voltage Balance Fault	Restart the battery. If the problem persists, please contact the after-sales service.
16		Inconsistent Master and Slave	Restart the battery. If the problem persists, please contact the after-sales service.
17		Temp. Sensor Fault	Restart the battery. If the problem persists, please contact the after-sales service.
18		Others	Contact the after-sales service.















Lynx Home F G2

No.	SOC indicator	Fault	Solutions
1		Battery Overvoltage	Power off and wait for 2 hours. If the problem persists, please contact the after-sales service.
2		Battery Undervoltage	Contact the after-sales service.
3		High Cell Temperature	<ol style="list-style-type: none"> 1. There are heat sources around the battery system, such as open flames, boilers, or other heating devices. Keep the battery system away from heat sources. 2. Power off the battery and wait for the temperature to recover before powering it on again. If the problem persists, please contact the after-sales service.
4		Excessive Temperature Difference	
5		Low Charging Temperature	<ol style="list-style-type: none"> 1. The environment temperature is too low. Check the environment to ensure that the installation temperature of the battery system meets the operating temperature range of the battery. 2. Power off the battery and wait for the temperature to recover before powering it on again.
6		Low Discharging Temperature	
7		Overcurrent Charging	Restart the battery. If the problem persists, please contact the after-sales service.
8		Overcurrent Discharging	Restart the battery. If the problem persists, please contact the after-sales service.
9		Low Insulation Resistance	Contact the after-sales service.
10		Voltage Difference Exception	Restart the battery and leave it for 12 hours. If the problem persists, please contact the after-sales service.
11		Inconsistent Cell	Some battery modules in the battery system have incorrect models. Please contact the dealer to replace the battery module and reinstall it.
12		Wire Harness Exception	Restart the battery. If the problem persists, please contact the after-sales service.
13		Relay Connection Failure	Restart the battery. If the problem persists, please contact the after-sales service.
14		Relay Adhesion	Restart the battery. If the problem persists, please contact the after-sales service.
15		Cluster Fault	Check the battery model. Contact the after-sale service if the battery model is incorrect.

16		Interlock Failure	Check whether the termination resistor is installed properly and restart the battery. If the problem persists, please contact the after-sales service.
17		BMU Communication Fault	Restart the battery. If the problem persists, please contact the after-sales service.
18		MCU Communication Fault	Restart the battery. If the problem persists, please contact the after-sales service.
19		Air Switch Adhesion	Contact the after-sales service.
20		Precharge Failure	Restart the battery. If the problem persists, please contact the after-sales service.
21		Relay Overtemperature	Power off and wait for 2 hours. If the problem persists, please contact the after-sales service.
22		Current Diverter Overtemperature	Power off and wait for 2 hours. If the problem persists, please contact the after-sales service.
23		Reverse Connection Fault	The positive and negative poles of the battery system power cable are reversed. Please reconnect the power cable.
24		Microelectronic Fault	Contact the after-sales service.

Lynx home D

No.	SOC indicator	Fault	Solutions
1		Battery Overvoltage	Power off and wait for 2 hours. If the problem persists, please contact the after-sales service.
2		Battery Undervoltage	Contact the after-sales service.
3		High Cell Temperature	Power off and wait for 2 hours. If the problem persists, please contact the after-sales service.
4		Low Charging Temperature	Power off and wait for the temperature recovers. If the problem persists, please contact the after-sales service.
5		Low Discharging Temperature	
6		Overcurrent Charging	Restart the battery. If the problem persists, please contact the after-sales service.
7		Overcurrent Discharging	

8		Excessive Temperature Difference	Power off and wait for 2 hours. If the problem persists, please contact the after-sales service.
9		Voltage Difference Exception	Restart the battery and leave it for 12 hours. If the problem persists, please contact the after-sales service.
10		Wire Harness Exception	Restart the battery. If the problem persists, please contact the after-sales service.
11		MOS cannot be closed	Restart the battery. If the problem persists, please contact the after-sales service.
12		MOS adhesion	Restart the battery. If the problem persists, please contact the after-sales service.
13		Cluster Fault	Check the battery model. Contact the after-sale service if the battery model is incorrect.
14		BMU Communication Fault	Restart the battery. If the problem persists, please contact the after-sales service.
15		MCU Communication Fault	Restart the battery. If the problem persists, please contact the after-sales service.
16		Precharge Failure	Restart the battery. If the problem persists, please contact the after-sales service.
17		MOS overtemperature fault	Power off and wait for 2 hours. If the problem persists, please contact the after-sales service.
18		Current Diverter Overtemperature	Power off and wait for 2 hours. If the problem persists, please contact the after-sales service.
19		BMS Hardware Overcurrent Fault	Power off and wait for 2 hours. If the problem persists, please contact the after-sales service.
20		DCDC Fault	Power off and wait for 2 hours. If the problem persists, please contact the after-sales service.
21		Microelectronic Fault	Contact the after-sales service.
22	Button indicator blinks red and SOC indicator off	Inverter communication loss	Check if the inverter communication cable is normal. If the problem persists after reconnecting, please contact the after-sales service.

12 Technical Parameters

12.1 Inverter Parameters

Technical parameters	GW15K-ET	GW20K-ET	GW25K-ET	GW29.9K-ET	GW30K-ET
Battery Input Data					
Battery Type	Li-Ion	Li-Ion	Li-Ion	Li-Ion	Li-Ion
Nominal Battery Voltage (V)	500	500	500	500	500
Battery voltage range (V)	200~800	200~800	200~800	200~800	200~800
Start-up Voltage (V)	180	180	180	180	180
Number of Battery Input	1	1	2	2	2
Max. Continuous Charging Current (A)	50	50	50×2	50×2	50×2
Max. Continuous Discharging Current (A)	50	50	50×2	50×2	50×2
Max Charge Power (W)	15,000	20,000	25,000	30,000	30,000
Max Discharge Power (W)	15,000	20,000	25,000	30,000	30,000
PV String Input Data					
Max. Input Power (W) ^{*1}	22,500	30,000	37,500	45,000	45,000
Max. Input Voltage (V) ^{*2}	1000	1000	1000	1000	1000
MPPT Operating Voltage Range (V)	200~850	200~850	200~850	200~850	200~850
MPPT Voltage Range at Nominal Power (V)	400~850	400~850	450~850	450~850	450~850
Start-up Voltage (V)	200	200	200	200	200
Nominal Input Voltage (V)	620	620	620	620	620
Max. Input Current per MPPT (A)	30	30	30	30	30
Max. Short Circuit Current per MPPT (A)	38	38	38	38	38
Max. Backfeed Current to The Array (A)	0	0	0	0	0
Number of MPPT	2	2	3	3	3
Number of Strings per MPPT	2/2	2/2	2/2/2	2/2/2	2/2/2
AC Output Data (On-grid)					
Nominal Output Power (W)	15,000	20,000	25,000	29,900	30,000

Max. Output Power (W)	15,000	20,000	25,000	29,900	30,000
Nominal Output Power at 40 °C(W) *14	15,000	20,000	25,000	29,900	30,000
Max. Output Power at 40 °C (W)*14	15,000	20,000	25,000	29,900	30,000
Nominal Apparent Power Output to Utility Grid (VA)	15,000	20,000	25,000	29,900	30,000
Max. Apparent Power Output to Utility Grid (VA)*3 *15	16,500	22,000	27,500	29,900	33,000
Nominal Apparent Power from Utility Grid(VA)	15,000	20,000	25,000	30,000	30,000
Max. Apparent Power from Utility Grid (VA) *12	15,000	20,000	25,000	30,000	30,000
Nominal Output Voltage (V)	380/400, 3L/N/PE	380/400, 3L/N/PE	380/400, 3L/N/PE	380/400, 3L/N/PE	380/400, 3L/N/PE
Output Voltage Range (V)*4	0~300	0~300	0~300	0~300	0~300
Nominal AC Grid Frequency (Hz)	50/60	50/60	50/60	50/60	50/60
AC Grid Frequency Range (Hz)	45~65	45~65	45~65	45~65	45~65
Max. AC Current Output to Utility Grid (A) *11	23.9	31.9	39.9	43.3	47.8
Max. AC Current From Utility Grid (A) *13	21.7	29.0	36.2	43.3	43.5
Nominal AC Current From Utility Grid (A)	21.7	29.0	36.2	43.3	43.5
Max. Output Fault Current (Peak and Duration) (A)	241.5A@126 ms	241.5A@126 ms	241.5A@126 ms	241.5A@126 ms	241.5A@126 ms
Inrush Current (Peak and Duration) (A)	264A@53us	264A@53us	264A@53us	264A@53us	264A@53us
Nominal Output Current (A)*5	21.7	29.0	36.2	43.3	43.5
Power Factor	~1 (Adjustable from0.8 leading~0.8 lagging)	~1 (Adjustable from0.8 leading~0.8 lagging)	~1 (Adjustable from0.8 leading~0.8 lagging)	~1 (Adjustable from0.8 leading~0.8 lagging)	~1 (Adjustable from0.8 leading~0.8 lagging)
Max. Total Harmonic Distortion	≤3.05%	≤3.05%	≤3.05%	≤3.05%	≤3.05%
Maximum Output Overcurrent Protection (A)	94	94	94	94	94
AC Output Data (Back-up)					

Back-up Nominal Apparent Power (VA)	15,000	20,000	25,000	29,900	30,000
Max. Output Apparent Power without Grid(VA)*6	15,000(18,000@60s , 24,000@3s)	20,000(24,000@60s , 32,000@3s)	25,000(30,000@60s)	30,000(36,000@60s)	30,000(36,000@60s)
Max. Output Apparent Power with Grid (VA)	15,000	20,000	25,000	29,900	30,000
Nominal Output Current (A)	22.7	30.3	37.9	45.5	45.5
Max. Output Current (A)	22.7(27.3@60s, 36.4@3s)	30.3(36.4@60s, 48.5@3s)	37.9(45.5@60s)	45.5(54.5@60s)	45.5(54.5@60s)
Max. Output Fault Current (Peak and Duration) (A)	94	94	94	94	94
Inrush Current (Peak and Duration) (A)	264@53us	264@53us	264@53us	264@53us	264@53us
Maximum Output Overcurrent Protection (A)					
Nominal Output Voltage (V)	380/400	380/400	380/400	380/400	380/400
Nominal Output Frequency (Hz)	50/60	50/60	50/60	50/60	50/60
Output THDv (@Linear Load)	<3%	<3%	<3%	<3%	<3%
Efficiency					
Max. Efficiency	98.0%	98.0%	98.0%	98.0%	98.0%
European Efficiency	97.5%	97.5%	97.5%	97.5%	97.5%
Max. Battery to AC Efficiency	97.5%	97.5%	97.5%	97.5%	97.5%
MPPT Efficiency	99.9%	99.9%	99.9%	99.9%	99.9%
Protection					
PV String Current Monitoring	Integrated	Integrated	Integrated	Integrated	Integrated
PV Insulation Resistance Detection	Integrated	Integrated	Integrated	Integrated	Integrated
Residual Current Monitoring	Integrated	Integrated	Integrated	Integrated	Integrated
PV Reverse Polarity Protection	Integrated	Integrated	Integrated	Integrated	Integrated
Battery Reverse Polarity Protection	Integrated	Integrated	Integrated	Integrated	Integrated
Anti-islanding Protection	Integrated	Integrated	Integrated	Integrated	Integrated
AC Overcurrent Protection	Integrated	Integrated	Integrated	Integrated	Integrated
AC Short Circuit Protection	Integrated	Integrated	Integrated	Integrated	Integrated
AC Overvoltage	Integrated	Integrated	Integrated	Integrated	Integrated

Protection					
DC Switch ^{*7}	Integrated	Integrated	Integrated	Integrated	Integrated
DC Surge Protection	Type II	Type II	Type II	Type II	Type II
AC Surge Protection	Type III	Type III	Type III	Type III	Type III
AFCI	Optional	Optional	Optional	Optional	Optional
Rapid Shutdown	Optional	Optional	Optional	Optional	Optional
Remote Shutdown	Integrated	Integrated	Integrated	Integrated	Integrated
General Data					
Operating Temperature Range (°C)	-35~+60	-35~+60	-35~+60	-35~+60	-35~+60
Operating Environment	Outdoor	Outdoor	Outdoor	Outdoor	Outdoor
Relative Humidity	0 ~ 95%	0 ~ 95%	0 ~ 95%	0 ~ 95%	0 ~ 95%
Max. Operating Altitude (m)	4000	4000	4000	4000	4000
Cooling Method	Smart Fan Cooling	Smart Fan Cooling	Smart Fan Cooling	Smart Fan Cooling	Smart Fan Cooling
Display	LED, WLAN+APP	LED, WLAN+APP	LED, WLAN+APP	LED, WLAN+APP	LED, WLAN+APP
Communication with BMS	RS485 / CAN	RS485 / CAN	RS485 / CAN	RS485 / CAN	RS485 / CAN
Communication with Meter	RS485	RS485	RS485	RS485	RS485
Communication with Portal	WiFi+LAN+Bluetooth (4G optional)	WiFi+LAN+Bluetooth (4G optional)	WiFi+LAN+Bluetooth (4G optional)	WiFi+LAN+Bluetooth (4G optional)	WiFi+LAN+Bluetooth (4G optional)
Weight (kg)	48	48	54	54	54
Dimension W×H×D (mm)	520×660×220	520×660×220	520×660×220	520×660×220	520×660×220
Noise Emission (dB)	<45	<45	<45	<60	<60
Topology	Non-isolated	Non-isolated	Non-isolated	Non-isolated	Non-isolated
Self-consumption at Night (W) ^{*8}	<15	<15	<15	<15	<15
Ingress Protection Rating	IP66	IP66	IP66	IP66	IP66
DC Connector	Stäubli Electrical Connectors AG	Stäubli Electrical Connectors AG	Stäubli Electrical Connectors AG	Stäubli Electrical Connectors AG	Stäubli Electrical Connectors AG

AC Connector	OT	OT	OT	OT	OT
Environmental Category	4K4H	4K4H	4K4H	4K4H	4K4H
Pollution Degree	III	III	III	III	III
Overvoltage Category	DC II / AC III	DC II / AC III	DC II / AC III	DC II / AC III	DC II / AC III
Protective Class	I	I	I	I	I
Storage Temperature (°C)	-45~+85	-45~+85	-45~+85	-45~+85	-45~+85
The Decisive Voltage Class (DVC)	Battery : C PV : C AC : C Com : A	Battery : C PV : C AC : C Com : A	Battery : C PV : C AC : C Com : A	Battery : C PV : C AC : C Com : A	Battery : C PV : C AC : C Com : A
Mounting Method	Wall Mounted	Wall Mounted	Wall Mounted	Wall Mounted	Wall Mounted
Active Anti-islanding Method	AFDPF + AQDPF *9	AFDPF + AQDPF *9	AFDPF + AQDPF *9	AFDPF + AQDPF *9	AFDPF + AQDPF *9
Type of Electrical Supply System	Three phase Grid	Three phase Grid	Three phase Grid	Three phase Grid	Three phase Grid
Country of Manufacture	China	China	China	China	China
Certification *10					
Grid Standards	VDE-AR-N 4105 · EN50549-1				
Safety Regulation	IEC62109-1&2				
EMC	EN61000-6-1, EN61000-6-2, EN61000-6-3, EN61000-6-4				
<p>*1: In Australia, for most of the PV module, the max.Input power can achieve 2*Pn, Such as the max.input power of GW15K-ET can achieve 30000W. Besides, Max. Input Power, not continuous for 1.5*normal power.</p> <p>*2: For 1000V system, Maximum operating voltage is 950V.</p> <p>*3: According to the local grid regulation.</p> <p>*4: Output Voltage Range: phase voltage.</p> <p>*5: For 380V grid, the Nominal Output Current is 22.7A for GW15K-ET, 30.3A for GW20K-ET, 37.9A for GW25K-ET, 45.3A GW29.9K-ET, and 45.5A for GW30K-ET.</p> <p>*6: Can be reached only if PV and battery power is enough.</p> <p>*7: DC Switch: GHX6-55P (for Australia).</p> <p>*8: No Back-up Output.</p> <p>*9: AFDPF: Active Frequency Drift with Positive Feedback, AQDPF: Active Q Drift with Positive Feedback.</p> <p>*10: Not all certifications & standards listed, check the official website for details.</p> <p>*11: For 380V grid, the Max. AC Current Output to Utility Grid is 25A for GW15K-ET, 33.3A for GW20K-ET, 41.7A for GW25K-ET, 49.8A for GW29.9K-ET, 50A for GW30K-ET.</p> <p>*12: When the load is connected to the inverter's backup port, the Max. Apparent Power from Utility Grid can reach to 22.5K for GW15K-ET, 30K for GW20k-ET, 33K for GW25K-ET, 33K for GW29.9K-ET,and 33K for GW30K-ET respectively.</p> <p>*13: When the load is connected to the inverter's backup port, the Max. AC Current From Utility Grid can reach to 34A for GW15K-ET, 45A for GW20k-ET, 50A for GW25K-ET, 50A for GW29.9K-ET,and</p>					

50A for GW30K-ET respectively.

*14: Nominal Output Power at 40 °C(W) and Max. Output Power at 40 °C (W) are only for Brazil.

*15: For Austria, Max. Output Power (W) is 15K for GW15K-ET, 20K for GW20K-ET, 25K for GW25K-ET, 29.9K GW29.9K-ET, and 30K for GW30K-ET.

12.2 Battery Parameters

Lynx Home F

Technical parameters	LX F6.6-H	LX F9.8-H	LX F13.1-H	LX F16.4-H
Usable Energy(kWh)* ¹	6.55	9.83	13.1	16.38
Battery Module	LX F3.3-H: 38.4V 3.27kWh			
Number of Modules	2	3	4	5
Cell Type	LFP (LiFePO ₄)			
Cell Configuration	64S1P	96S1P	128S1P	160S1P
Nominal Voltage (V)	204.8	307.2	409.6	512
Operating Voltage Range (V)	182.4~230.4	273.6~345.6	364.8~460.8	456~576
Nominal Dis-/Charge Current (A)* ²	25			
Nominal Power (kW)* ²	5.12	7.68	10.24	12.80
Operating Temperature (°C)	Charge: 0 ~ +50; Discharge: -20 ~ +50			
Relative Humidity	0~95%			
Max. Operating Altitude (m)	2000			
Communication	CAN			
Weight (kg)	115	158	201	244
Dimensions (W×H×D mm)	600*625*380	600*780*380	600*935*380	600*1090*380
Enclosure Type	IP55			
Installation Location	Grounded			
Standard and Certification	Safety	IEC62619, IEC62040, CEC		
	EMC	CE, RCM		
	Transportation	UN38.3		
*1: Test conditions, 100% DOD, 0.2°C charge & discharge at +25±2 °C for battery system at beginning life. System Usable Energy may vary with different Inverter.				
*2: Nominal Dis-/Charge Current and power derating will occur related to Temperature and SOC.				

Technical parameters		LX F6.6-H	LX F9.8-H	LX F13.1-H	LX F16.4-H
Usable Energy(kWh)* ¹		6.55	9.83	13.1	16.38
Battery Module		LX F3.3-H: 38.4V 3.27kWh			
Number of Modules		2	3	4	5
Cell Type		LFP (LiFePO ₄)			
Cell Configuration		64S1P	96S1P	128S1P	160S1P
Nominal Voltage (V)		204.8	307.2	409.6	512
Operating Voltage Range (V)		182.4~230.4	273.6~345.6	364.8~460.8	456~576
Nominal Dis-/Charge Current (A)* ²		25			
Nominal Power (kW)* ²		5.12	7.68	10.24	12.80
Short-Circuit Current		2.62kA@1.62ms			
Operating Temperature Range (°C)		Charge: 0 ~ +50; Discharge: -20 ~ +50			
Relative Humidity		0~95%			
Max. Operating Altitude (m)		2000			
Communication		CAN			
Weight (kg)		115	158	201	244
Dimensions (W×H×D mm)		600×610×380	600×765×380	600×920×380	600×1075×380
Ingress Protection Rating		IP55			
Storage Temperature (°C)		-20 ~ +45 (≤ One Month); 0 ~ +35 (≤ One Year)			
Mounting Method		Grounded			
Round-trip Efficiency		96.4%			
Cycle Life* ³		≥ 3500 @1C/1C			
Standard and Certification	Safety	IEC62619, IEC 62040, VDE2510-50, CEC,CE			
	EMC	CE, RCM			
	Transportation	UN38.3			
<p>*1: Test conditions, 100% DOD, 0.2°C charge & discharge at +25±2 °C for battery system at beginning life. System Usable Energy may vary with different Inverter.</p> <p>*2: Nominal Dis-/Charge Current and power derating will occur related to Temperature and SOC.</p> <p>*3: Based on 2.5~3.65V voltage rang @25±2°C of Cell under 1C/1C test condition and 80% EOL.</p>					

Technical parameters	LX F12.8-H-2 0	LX F16.0-H-2 0	LX F19.2-H-2 0	LX F22.4-H-2 0	LX F25.6-H-2 0	LX F28.8-H-2 0
Usable Energy (kWh) ^{*1}	12.8	16.0	19.2	22.4	25.6	28.8
Battery Module	LX F3.2-20: 64V 3.2kWh					
Number of Modules	4	5	6	7	8	9
Cell Type	LFP (LiFePO4)					
Cell Configuration	(20S)4S1P	(20S)5S1P	(20S)6S1P	(20S)7S1P	(20S)8S1P	(20S)9S1P
Nominal Voltage (V)	256	320	384	448	512	576
Operating Voltage Range (V)	229.6~288.8	287~361	344.4~433.2	401.8~505.4	459.2~577.6	516.6~649.8
Nominal Dis-/Charge Current (A) ^{*2}	35					
Nominal Power (kW) ^{*2}	8.96	11.2	13.44	15.68	17.92	20.16
Operating Temperature Range (°C)	Charge: 0~+50; Discharge: -20~+50					
Relative Humidity	0 ~ 95%					
Max. Operating Altitude (m)	3000					
Communication	CAN					
Weight (kg)	154	188	222	256	290	324
Dimension (W×H×D mm)	600×871×380	600×1027×380	600×1183×380	600×1339×380	600×1495×380	600×1651×380
Ingress Protection Rating	IP55					
Storage Temperature (°C)	-20~+45(≤One Month) ; 0~+35(≤One Year)					
Mounting Method	Grounded					
Round-trip Efficiency	94%					
Cycle Life ^{*3}	>4000					
Standard and Certification	Safety	IEC62619, IEC62040-1, IEC63056, VDE2510, CE, CEC				
	EMC	CE, RCM				
	Transportation	UN38.3				
<p>*1: Test conditions, 100% DOD, 0.2°C charge & discharge at +25±2 °C for battery system at beginning life. System Usable Energy may vary with different inverter.</p> <p>*2: Nominal Dis-/Charge Current and power derating will occur related to Temperature and</p>						

SOC.

- When a single battery system is applied, the Nominal Dis-/Charge Current is 35A.
- When two battery systems are applied, the Nominal Dis-/Charge Current is 70A.
- When more than three battery systems are applied, the Nominal Dis-/Charge Current is 100A.

*3: Based on 2.5~3.65V voltage rang @25±2°C of Cell under 0.7C/1C test condition and 80% EOL.

Lynx home D

Technical parameters		LX D5.0-10
Usable energy (kWh)*1		5
Cell Type		LFP (LiFePO4)
Cell Configuration		16S1P
Nominal Voltage (V)		Charge: 435V; Discharge: 380V
Operating Voltage Range (V)		320~480V
Nominal Charge/Discharge Power (kW)		3
Peak Power		5KW, 10s
Operating Temperature Range (°C)		Charge: 0~+53; Discharge: -20~+53
Relative Humidity		0~95%
Max. Operating Altitude (m)		4000
Communication		CAN
Weight (kg)		52
Dimension (W×H×D mm)		700×380×170
Ingress Protection Rating		IP66
Storage Temperature (°C)		-20~0 (≤ One Months), 0~+35 (≤ One Year)
Mounting Method		Floor stacked, Wall Mounted
Cycle Life *2		4500
Standard and Certification	Safety	IEC62619、IEC60730、VDE2510-50、CE、CEC
	EMC	CE, RCM
	Transportation	UN38.3

*1: Test conditions, 100% DOD, 0.2C charge & discharge at +25±3 °C for battery system at beginning life. Usable energy may vary with different inverter.

*2: Based on 2.87~3.59V voltage rang @25±2 °C of Cell under 0.6C/0.6C test condition and 80% EOL

12.3 Smart Meter Parameters

Technical parameters		GM3000	
Input	Grid	Three-phase	
	Voltage	Nominal Voltage-Line to N (Vac)	230
		Nominal Voltage-Line to Line (Vac)	400
		Voltage Range	0.88Un-1.1Un
		Nominal AC Grid Frequency (Hz)	50/60
	Current	Current Transformer Ratio	120A:40mA
Number of Current Transformers		3	
Communication		RS485	
Communication Distance (m)		1000	
User interface		3 LED, Reset button	
Accuracy	Voltage/Current	Class 1	
	Active Energy	Class 1	
	Reactive Energy	Class 2	
Power Consumption(W)		<3	
Mechanical	Dimensions (W×H×D mm)	36*85*66.5	
	Weight (g)	450	
	Mounting	Din rail	
Environment	Ingress Protection Rating	IP20	
	Operating Temperature Range (°C)	-25~60	
	Storage Temperature Range(°C)	-30~70	
	Relative Humidity (non-condensing)	0~95%	
	Max. Operating Altitude (m)	2000	

Technical parameters		GM330	
Input	Grid	Three-phase	
	Voltage	Nominal Voltage-Line to N (Vac)	230
		Nominal Voltage-Line to Line (Vac)	380/400
		Voltage Range	0.88Un-1.1Un
		Nominal AC Grid Frequency (Hz)	50/60
Current	Current Transformer Ratio	nA:50A	
Communication		RS485	

Communication Distance (m)		1000
User interface		4 LED, Reset button
Accuracy	Voltage/Current	Class 0.5
	Active Energy	Class 0.5
	Reactive Energy	Class 1
Power Consumption(W)		<5
Mechanical	Dimensions (W×H×D mm)	72*85*72
	Weight (g)	240
	Mounting	Din rail
Environment	Ingress Protection Rating	IP20
	Operating Temperature Range (°C)	-30~70
	Storage Temperature Range(°C)	-30~70
	Relative Humidity (non-condensing)	0~95%
	Max. Operating Altitude (m)	3000

12.4 Smart Dongle Parameters

Technical parameters		WiFi/LAN Kit-20
Input voltage (V)		5
Power Consumption (W)		≤3
Connection Interface		USB
Communication	Ethernet Interface	10M/100Mbps Self-adaption
	WLAN	IEEE 802.11 b/g/n @2.4 GHz
	Bluetooth	Bluetooth V4.2 BR/EDR Bluetooth LE Specification
Mechanical Parameters	Dimensions (W×H×D mm)	48.3*159.5*32.1
	Weight (g)	82
	Ingress Protection Rating	IP65
	Installation	Plug and Play
Operating Temperature Range (°C)		-30 - 60°C
Storage Temperature Range (°C)		-40 - 70°C

Relative Humidity	0-95%
Max. Operating Altitude (m)	4000

Technical parameters	Wi-Fi Kit
General Data	
Max. Inverters Supported	1
Connection Interface	USB
Installation	Plug and Play
Indicator	LED Indicator
Dimensions (W×H×D mm)	49*96*32
Weight(g)	59
Ingress Protection Rating	IP65
Power Consumption (W)	2
Operating Temperature Range (°C)	-30 - 60°C
Storage Temperature Range (°C)	-40 - 70°C
Relative Humidity	0-100% (non-condensing)
Max. Operating Altitude (m)	4000
Wireless Parameter	
Supported Standards & Frequencies	802.11b/g/n(2.412G-2.472G)
Operating Mode	AP/STA/AP+STA

Technical parameters	Ezlink3000
General Data	
Connection Interface	USB
Ethernet Interface (optional)	10/100Mbps self-adaption, Communication distance ≤ 100m
Installation	Plug and Play
Indicator	LED Indicator
Dimensions (W×H×D mm)	48*153*32
Weight (g)	130

Ingress Protection Rating	IP65
Power Consumption (W)	<2 (typical)
Operating Mode	STA
Wireless Parameter	
Bluetooth Communication	Bluetooth 5.1
WiFi Communication	802.11b/g/n (2.412G-2.484G)
Environment	
Operating Temperature Range (°C)	-30 - 60°C
Storage Temperature Range (°C)	-40 - 70°C
Relative Humidity	0-100% (non-condensing)
Max. Operating Altitude (m)	4000

13 Appendix

13.1 FAQ

13.1.1 How to Perform Meter/CT Detection?

Meter/CT-Assisted Test is used to auto-check if the Smart Meter and CT are connected in the right way and their working status.

Step 1 Tap **Home > Settings > Meter/CT Assisted Test** to set the function.

Step 2 Tap **Start Test** to start test. Check Test Result after test.

13.1.2 How to Upgrade Firmware Version

Check and upgrade the DSP version, ARM version, BMS version, AFCI version of the inverter, or firmware version of the communication module. Some devices do not support upgrading the firmware version through SolarGo app.

Method I

If the Firmware Upgrade dialog box pops up once logging into the app, click Firmware Upgrade to directly go to the firmware information page.

When prompted by a red dot on the right of the Firmware Information, click to get the firmware update information.

During the upgrade process, ensure that the network is stable and the device remains connected to SolarGo, otherwise the upgrade may fail.

Step 1 Tap **Home > Settings > Firmware Upgrade** to check the firmware version. If the Firmware Upgrade dialog box pops up once logging into the app, click Firmware Upgrade to directly go to the firmware information page.

Step 2 (Optional) Tap **Check For Update** to check whether there is the latest version to be updated.

Step 3 Tap **Firmware Upgrade** as prompted to enter the firmware upgrade page.

Step 4 (Optional) Tap **Learn More** to check the firmware related information, such as **Current Version, New Version, Update Record**, etc.

Step 5 Tap **Upgrade** and follow the prompts to complete the upgrading.

Method II

The automatic upgrade function is allowed only when a WiFi/LAN Kit-20 or WiFi Kit-20 module is applied, and the module firmware version is V2.0.1 and above.

After enabling the auto-upgrade function, if there is any update and the device is connected to the network, the corresponding firmware version can be automatically upgraded.

Step 1 Tap **Home > Settings > Firmware Upgrade** to check the firmware version.

Step 2 Enable or disable the **Automatic Upgrade** based on actual needs.

13.2 Acronyms and Abbreviations

U_{batt}	Battery Voltage Range
------------	-----------------------

$U_{batt,r}$	Nominal Battery Voltage
$I_{batt,max (C/D)}$	Max. Continuous Charging Current Max. Continuous Discharging Current
$E_{C,R}$	Rated Energy
U_{DCmax}	Max.Input Voltage
U_{MPP}	MPPT Operating Voltage Range
$I_{DC,max}$	Max. Input Current per MPPT
$I_{SC PV}$	Max. Short Circuit Current per MPPT
$P_{AC,r}$	Nominal Output Power
S_r (to grid)	Nominal Apparent Power Output to Utility Grid
S_{max} (to grid)	Max. Apparent Power Output to Utility Grid
S_r (from grid)	Nominal Apparent Power from Utility Grid
S_{max} (from grid)	Max. Apparent Power from Utility Grid
$U_{AC,r}$	Nominal Output Voltage
$f_{AC,r}$	Nominal AC Grid Frequency
$I_{AC,max(to grid)}$	Max. AC Current Output to Utility Grid
$I_{AC,max(from grid)}$	Max. AC Current From Utility Grid
P.F.	Power Factor
S_r	Back-up Nominal apparent power
S_{max}	Max. Output Apparent Power (VA) Max. Output Apparent Power without Grid
$I_{AC,max}$	Max. Output Current
$U_{AC,r}$	Nominal Output Voltage
$f_{AC,r}$	Nominal Output Frequency
$T_{operating}$	Operating Temperature Range
$I_{DC,max}$	Max. Input Current
U_{DC}	Input Voltage
$U_{DC,r}$	DC Power Supply
U_{AC}	Power Supply/AC Power Supply
$U_{AC,r}$	Power Supply/Input Voltage Range
$T_{operating}$	Operating Temperature Range
P_{max}	Max Output Power
P_{RF}	TX Power
P_D	Power Consumption
$P_{AC,r}$	Power Consumption

$F_{(Hz)}$	Frequency
$I_{SC\ PV}$	Max. Input Short Circuit Current
$U_{dcmin}-U_{dcmax}$	Range of input Operating Voltage
$U_{AC,rang(L-N)}$	Power Supply Input Voltage
$U_{sys,max}$	Max System Voltage
$H_{altitude,max}$	Max. Operating Altitude
PF	Power Factor
THDi	Total Harmonic Distortion of Current
THDv	Total Harmonic Distortion of Voltage
C&I	Commercial & Industrial
SEMS	Smart Energy Management System
MPPT	Maximum Power Point Tracking
PID	Potential-Induced Degradation
Voc	Open-Circuit Voltage
Anti PID	Anti-PID
PID Recovery	PID Recovery
PLC	Power-line Communication
Modbus TCP/IP	Modbus Transmission Control / Internet Protocol
Modbus RTU	Modbus Remote Terminal Unit
SCR	Short-Circuit Ratio
UPS	Uninterrupted Power Supply
ECO mode	Economical Mode
TOU	Time of Use
ESS	Energy Storage System
PCS	Power Conversion System
SPD	Surge Protection Device
DRED	Demand Response Enabling Device
RCR	Ripple Control Receiver
AFCI	AFCI
GFCI	Ground Fault Circuit Interrupter
RCMU	Residual Current Monitoring Unit
FRT	Fault Ride Through
HVRT	High Voltage Ride Through
LVRT	Low Voltage Ride Through
EMS	Energy Management System

BMS	Battery Management System
BMU	Battery Measure Unit
BCU	Battery Control Unit
SOC	State of Charge
SOH	State of Health
SOE	State Of Energy
SOP	State Of Power
SOF	State Of Function
SOS	State Of Safety
DOD	Depth of discharge

13.3 Term Explanation

Overvoltage category definition

Category I: Applies to equipment connected to a circuit where measures have been taken to reduce transient overvoltage to a low level.

Category II: Applies to equipment not permanently connected to the installation. Examples are appliances, portables tools and other plug-connected equipment.

Category III: Applies to a fixed equipment downstream, including the main distribution board. Examples are switch gear and other equipment in an industrial installation.

Category IV: Applies to equipment permanently connected at the origin of an installation (upstream of the main distribution board). Examples are electricity meters, primary over-current protection equipment and other equipment connected directly to outdoor open lines.

Moisture location category definition

Parameters	Level		
	3K3	4K2	4K4H
Moisture Parameters	0 - +40°C	-33 - +40°C	-33 - +40°C
Temperature Range	5% - 85%	15% - 100%	4% - 100%

Environment category definition

Outdoor: Ambient Temperature: -25~+60°C, applied to Pollution Degree 3 environment.

Indoor Unconditioned: Ambient Temperature: -25~+40°C, applied to Pollution Degree 3 environment.

Indoor conditioned: Ambient Temperature: 0~+40°C, applied to Pollution Degree 2 environment.

Pollution degree definition

Pollution Degree I: No pollution or only dry, non-conductive pollution occurs. The pollution has no

influence.

Pollution Degree II: Normally only non-conductive pollution occurs. Occasionally, however, a temporary conductivity caused by condensation must be expected.

Pollution Degree III: Conductive pollution occurs, or dry, non-conductive pollution occurs, which becomes conductive due to condensation, which is expected.

Pollution Degree IV: Persistent conductive pollution occurs, for example, the pollution caused by conductive dust, rain or snow.